

DF1-ST

**DIVISORE DI FLUSSO TIPO STANDARD
GEAR FLOW DIVIDER STANDARD TYPE**

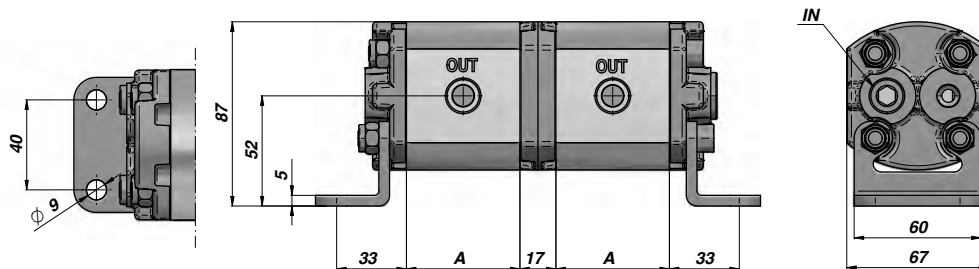
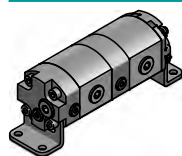

Tipo Type	cm3/giro cm3/rev	Q l/min for element			P1 MAX bar	P3 MAX bar	A	IN BSP	OUT BSP	kg
		Min.	Optimal	Max.						
DF 1 - (ST) 0.9	0.89	1.0	2.0	4.2	240	260	37.60	3/8"	3/8"	0,42
DF 1 - (ST) 1.2	1.18	1.5	3.0	5.6	240	260	38.70	3/8"	3/8"	0,44
DF 1 - (ST) 1.6	1.60	1.9	3.8	7.6	240	260	40.40	3/8"	3/8"	0,46
DF 1 - (ST) 2.5	2.50	2.5	5.8	12.0	220	250	43.90	3/8"	3/8"	0,50
DF 1 - (ST) 3.7	3.70	3.7	8.3	13.3	210	240	48.60	3/8"	3/8"	0,56
DF 1 - (ST) 5.0	5.00	5.0	11.2	18.0	180	210	53.60	3/8"	3/8"	0,63
DF 1 - (ST) 7.8	7.76	8.4	15.9	27.9	170	190	64.40	3/8"	3/8"	0,77

P1 = PRESSIONE MAX. DI ESERCIZIO - MAX. WORKING PRESSURE

P3 = PRESSIONE MAX. DI PICCO - MAX. PEAK PRESSURE

I dati della tabella sono riferiti ad un singolo elemento

The data of the table refer to a single element

DF2-ST

**DIVISORE DI FLUSSO TIPO STANDARD
GEAR FLOW DIVIDER STANDARD TYPE**

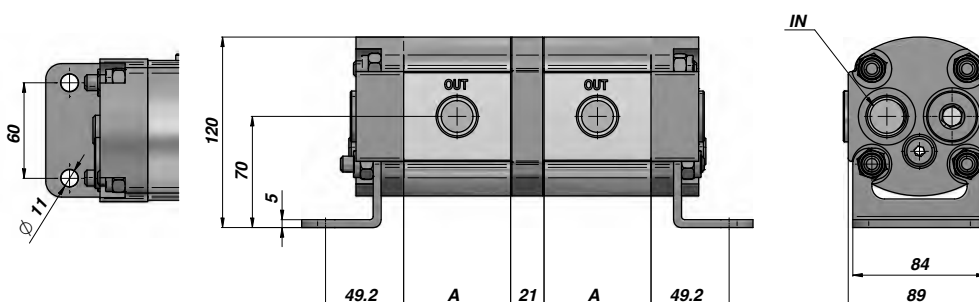
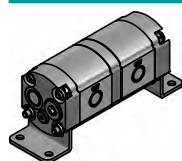

Tipo Type	cm3/giro cm3/rev	Q l/min for element			P1 MAX bar	P3 MAX bar	A	IN BSP	OUT BSP	kg
		Min.	Optimal	Max.						
DF 2 - (ST) 8	8.5	10.2	14.2	26.0	250	270	58.3	3/4"	1/2"	1,24
DF 2 - (ST) 11	11.0	13.2	19.4	33.0	250	270	62.4	3/4"	3/4"	1,33
DF 2 - (ST) 14	14.0	16.8	25.9	42.0	250	270	67.4	3/4"	3/4"	1,44
DF 2 - (ST) 16	16.5	19.8	29.2	49.0	230	240	71.6	3/4"	3/4"	1,55
DF 2 - (ST) 22	22.5	27.0	41.9	67.0	190	200	81.6	3/4"	3/4"	1,80
DF 2 - (ST) 26	26.0	31.2	45.4	78.0	170	180	87.4	3/4"	3/4"	1,94

P1 = PRESSIONE MAX. DI ESERCIZIO - MAX. WORKING PRESSURE

P3 = PRESSIONE MAX. DI PICCO - MAX. PEAK PRESSURE

I dati della tabella sono riferiti ad un singolo elemento

The data of the table refer to a single element