



INTERPUMP

FLUID SOLUTIONS 

Powered by I.M.M. Hydraulics

ADATTATORI

2022



Indice

Come ordinare.....	1
Rintracciabilità.....	2
Introduzione	3
Adattatori metrici	4
Adattatori ORFS.....	5
Adattatori JIC	6
Adattatori BSP.....	7
Adattatori NPT/NPTF.....	8
Trattamenti superficiali.....	9
Dimensioni porte e maschi di estremità filettati.....	11
Scelta della tubazione.....	19
Istruzioni di assemblaggio.....	22
Raccordi orientabili senza anello di ritegno	25
Raccordi DKO	26
Nippli a saldare.....	27
Progettazione ed installazione assemblati	30
Raccomandazioni.....	31
Guarnizioni elastomeriche.....	34
Coppie di serraggio.....	36
Assemblaggio su porte.....	40
Appendice.....	44
Norme di riferimento.....	48

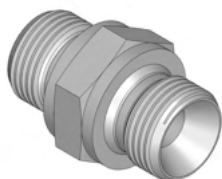

COME ORDINARE

Codice: 1700-12-12

Descrizione: Niplo di giunzione BSP 3/4"

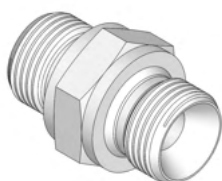

Codice: 1700-12-12NI

Descrizione: Niplo di giunzione BSP 3/4"

Trattamento Zinco-Nichel

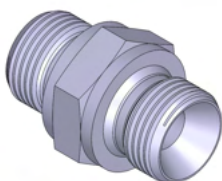

Codice: X1700-12-12

Descrizione: Niplo di giunzione BSP 3/4" Inox AISI 316L

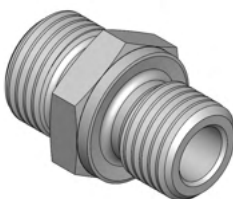

Codice: 7430-16SR-1NI

Descrizione: Terminale DIN dritto 16 S- G 1/2 (Form B ISO 1179-4) - SOLO CORPO - (ZINC-NICKEL)

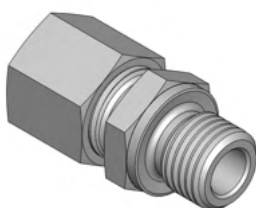

Codice: 7430-16SRNI

Descrizione: Terminale DIN dritto 16 S- G 1/2 (Form B ISO 1179-4) - (ZINC-NICKEL)

Note: completo di dado (cod. 7400) e anello tagliente (cod. 7410)

RINTRACCIABILITÀ

Al fine di garantire la rintracciabilità degli adattatori in termini di lotto, materiale e fornitore, la I.M.M. Hydraulics Spa ha implementato un sistema dedicato di marcatura come rappresentato nelle figure seguenti. Si tratta di un valore aggiunto evidente in linea con l'approccio alla gestione della qualità totale dell'azienda.

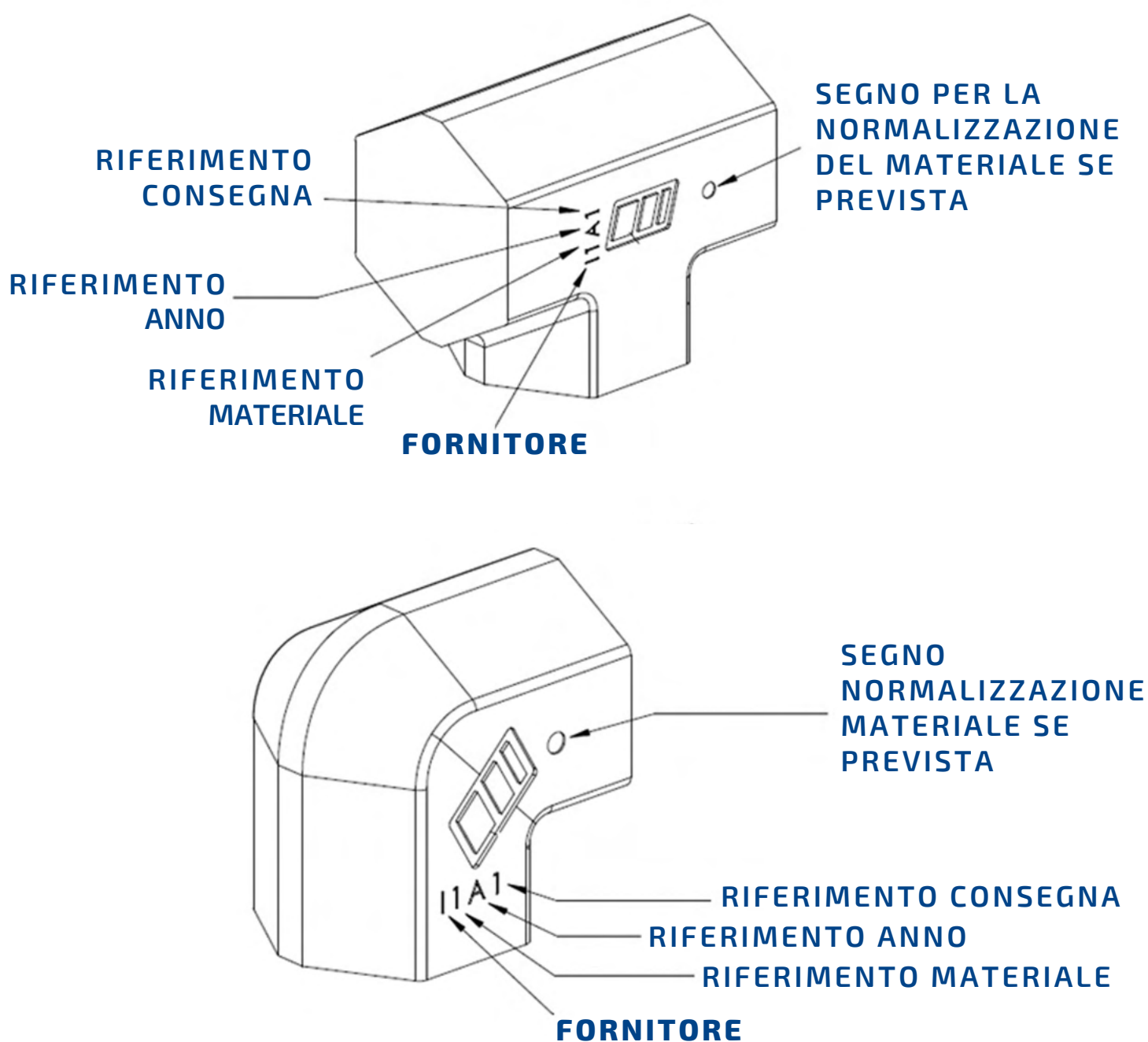

INTRODUZIONE

Nei sistemi idraulici risulta necessario poter installare adattatori per completare il circuito di riferimento.

Le funzioni principali degli adattatori sono:

- Adattare la dimensione della filettatura (ridurre o aumentare la filettatura);
- Convertire la filettatura: passaggio da un tipo di connessione ad un altro per facilitare la connessione a tubi flessibili o la raccordatura a tubi rigidi;
- Adattare le estremità del tubo: passaggio da tubo a connessione, passaggio da tubo a tubo;
- Chiusura: tappi per chiudere i circuiti.

Gli adattatori possono avere diversi tipi di filettatura: Metrica, BSPP, BSPT, SAE, UN/UNF, NPT/NPTF.

Filettatura	Norma
Metrica	ISO 261, ANSI B1.13M
BSPP	BS 2779, ISO 228/1
BSPT	BS21, ISO 7/1
NPT	ANSI B1.21.1
NPTF	SAE J476, ANSI B1.20.3
NPSM	ANSI B1.20.1
UN/UNF	ANSI B1.1

Sistemi di Connessione e Norme di riferimento

ADATTATORI METRICI

Comunemente chiamati DIN, gli adattatori metrici sono conformi allo standard internazionale ISO 8434-1 equivalente agli standard europei DIN 2353, DIN 3861 e DIN 3859.

Garantiscono la tenuta tramite superfici di tenuta coniche a 24°, con o senza o-ring (metallo su metallo) e filettatura metrica.

sezione di una tipica connessione con cono 24° e tagliente

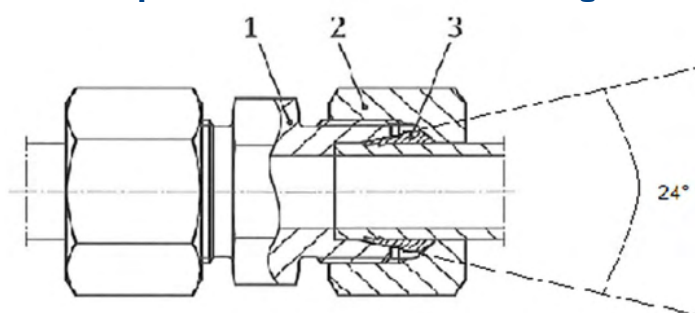

LEGENDA

- 1 - corpo
- 2 - dado
- 3 - anello tagliente

sezione di una tipica connessione con cono 24° e O-Ring

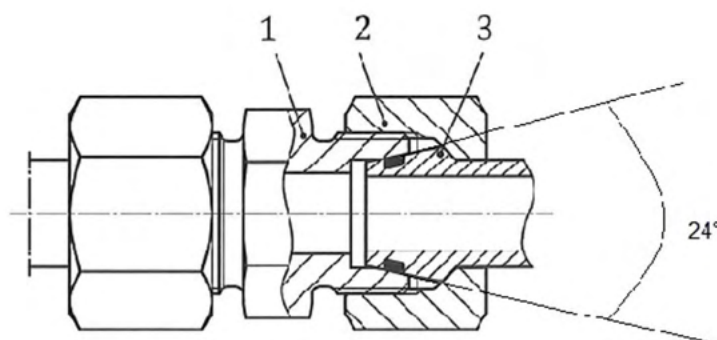

LEGENDA

- 1 - corpo
- 2 - dado
- 3 - terminale DKO (con o-ring)

Gli adattatori metrici, diffusi soprattutto in Germania, trovano largo impiego soprattutto tra i costruttori di macchinari (OEM), nel settore agricolo ed industriale. Il sistema di tenuta garantisce prestazioni elevate in termini di pressioni, assenza di perdite, buona resistenza a serraggi elevati, possibilità di effettuare montaggi e smontaggi ripetuti sostituendo le guarnizioni.

ADATTATORI ORFS

Gli adattatori ORFS sono conformi alle norme ISO 8434-3 e SAE J1453- Questo tipo di accoppiamento è progettato per garantire la migliore tenuta alle alte pressioni. La tenuta viene assicurata dalla compressione dell'o-ring presente sul maschio contro la faccia piana della femmina. La filettatura UN/UNF garantisce meccanicamente l'accoppiamento.

sezione e componenti di una tipica connessione ORFS

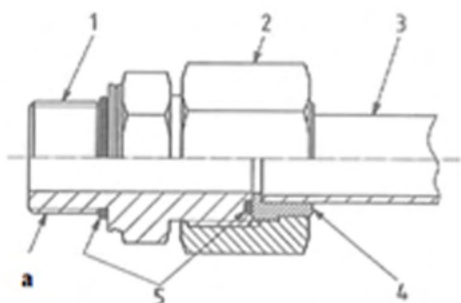

LEGENDA

- 1 - corpo connettore maschio diritto
- 2 - dado tubo
- 3 - tubo
- 4 - bussola
- 5 - o-ring

a - Terminale maschio secondo ISO 6149-2

Gli adattatori ORFS sono maggiormente utilizzati negli USA ed in Europa e trovano largo impiego soprattutto nei costruttori di primi impianti (OEM) nel settore macchine per movimento terra. Il sistema di tenuta garantisce ottime prestazioni alle alte pressioni e in condizioni di vibrazioni, assenza di perdite, buona resistenza a serraggi elevati, possibilità di effettuare montaggi e smontaggi ripetuti sostituendo le guarnizioni.

ADATTATORI JIC

Gli adattatori comunemente chiamati JIC sono conformi alle norme ISO 8434-2 e SAE J 514. Garantiscono la tenuta mediante accoppiamento metallo-metallo con un angolo di svasatura di 37° senza deformazione del singolo componente. Le filettature sono cilindriche UN/UNF.

sezione di una tipica connessione a 37°

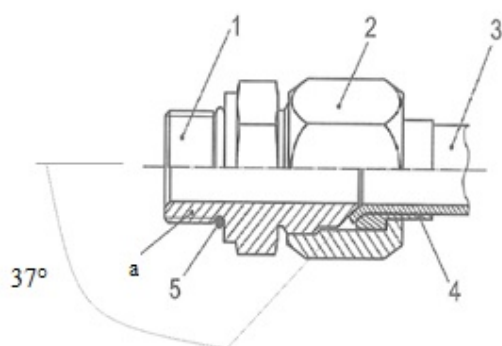

LEGENDA

- 1 - corpo connettore maschio dritto
- 2 - dado tubo
- 3 - tubo
- 4 - bussola
- 5 - o-ring

a - Terminale maschio in accordo a ISO 1179-3, ISO 6149, ISO 9974-2 o ISO 11926-3

Gli adattatori JIC sono maggiormente utilizzati negli USA trovano impiego soprattutto nel settore industriale. Il sistema di tenuta garantisce buone prestazioni a pressioni medio-alte.

ADATTATORI BSP

Le norme di riferimento sono la ISO 8434-6 e la BS 5200.

Per la connessione BSPP la tenuta è garantita dal contatto di superfici coniche, con angolo di 60°, con o senza o-ring.

La connessione BSPT realizza la tenuta sulla filettatura tramite l'aggiunta di materiali sigillanti.

La forma della filettatura ha un semiangolo dei fianchi di 55 gradi.

Sezione di una tipica connessione 60° con O-Ring

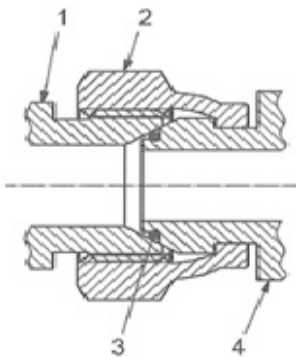

LEGENDA

- 1 - corpo (maschio)
- 2 - dado
- 3 - o-ring
- 4 - femmina

La connessione BSP è largamente usata in Europa, Giappone e nell'area Commonwealth. Le applicazioni industriali sono le più frequenti.

ADATTATORI NPT/NPTF

Gli adattatori NPT/NPTF sono conformi rispettivamente alla ANSI B1.21.1 e SAE J476, ANSI B1.20.3.

Sono caratterizzati da filettature coniche, con semiangolo dei fianchi di 60 gradi.

Nella connessione NPT/NPTF la tenuta viene effettuata sulla filettatura con l'ausilio di appropriati materiali sigillanti.

Se sul nipplo viene realizzato un semiangolo di 30°, la tenuta può essere effettuata in accoppiamento con femmina girevole NPSM.

La connessione NPT/NPTF è maggiormente utilizzata negli USA, dove trova impiego soprattutto nel settore industriale per il trasferimento in pressione di fluidi.

Il sistema di tenuta garantisce buone prestazioni con pressioni medio alte in condizioni statiche, per applicazioni dinamiche, soprattutto per le dimensioni maggiori di 1", è consigliabile utilizzare altri tipi di connessioni.

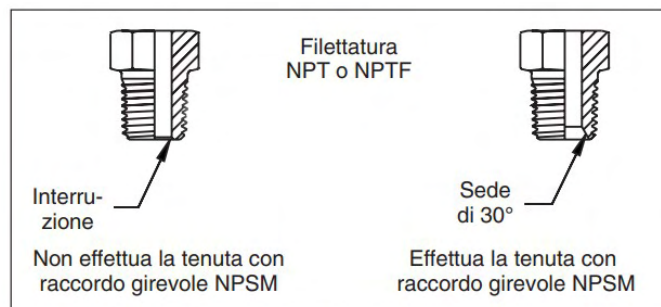

L'illustrazione mostra la sede di 30° sulle filettature NPT/NPTF necessaria affinché il raccordo girevole NPSM possa effettuare la tenuta.

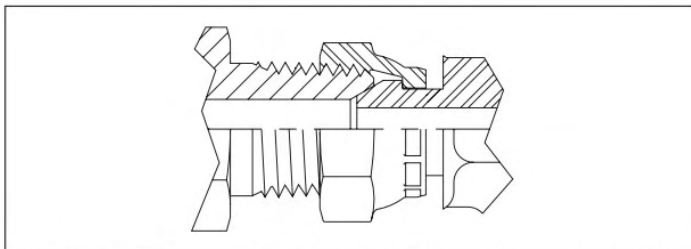

L'illustrazione mostra come gli adattatori girevoli NPSM effettuino la tenuta sulla scanalatura corrispondente nella filettatura maschio NPT.

TRATTAMENTI SUPERFICIALI

IFS si avvale dei propri impianti per la realizzazione dei trattamenti superficiali quali Zinco «standard» e Zinco nichel, assicurando gli elevati standard qualitativi e prestazionali richiesti dal mercato.



I nostri impianti assicurano un basso impatto ambientale ottemperando alle più stringenti norme in termini di ambiente e sicurezza.

La passivazione esente da Cromo esavalente assicura un basso impatto ambientale. La sigillatura oltre ad aumentare le performance del prodotto, è studiata per assicurare valori di coefficiente di attrito contenuti.

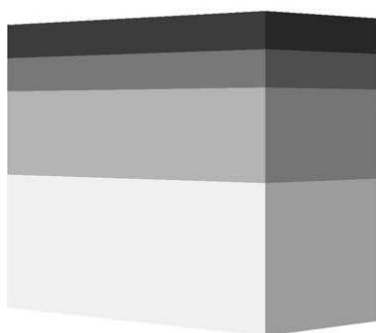

SIGILLATURA
 PASSIVAZIONE
 ZINCO/ZINCO-NICHEL
 ACCIAIO

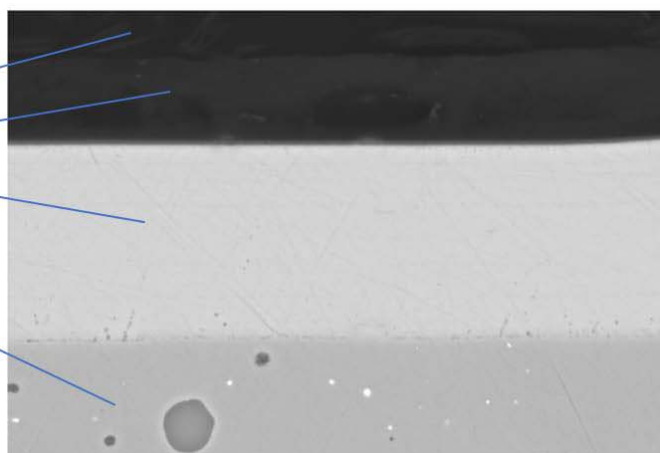

Le soluzioni disponibili assicurano una elevata affidabilità in tutti gli ambienti di lavoro:

Tattamento Zinco «standard» in accordo alla specifica ISO 2081 Fe/Zn8/C/T2

Il trattamento zinco standard, con spessore minimo di Zinco puro di 8µm e passivazione bianca assicura una resistenza alla corrosione superiore allo standard di mercato.

L'aspetto è metallico opaco.



FINITURA FINISHING	SPESSORE THICKNESS	RESISTENZA MINIMA RUGGINE ROSSA MINIMUM RESISTANCE RED RUST
White zinc-plating without Cr VI No Seal Zincatura bianca esente da Cromo VI e senza sigillatura	>8	>400 h

Tattamento Zn-Ni in accordo alla specifica ISO 19598 Fe//ZnNi8//An//T2

Il trattamento zinco nichel (rivestimento di lega Zn-Ni (Ni 12%-16%, spessore 8-12 micron) presenta una colorazione grigio-azzurra con leggera iridescenza. Indicato quando sia richiesta un'elevata resistenza alla corrosione in condizioni di esposizione gravose. Il trattamento zinco nichel viene offerto std per gli adattatori DIN 2353 - ISO 8434-1



FINITURA	SPESSORE	RESISTENZA MINIMA RUGGINE ROSSA
Blue trasparente, passivazione con base cromo trivalente (esente da cromo VI). Transparent-blue (colorless), passivation based on trivalent chromium (chromium VI free)	>8	>720 h

DIMENSIONI PORTE E MASCHI DI ESTREMITA' FILETTATI

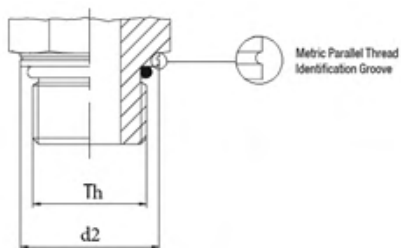

Raccordi Dritti

Filettatura Metrica
ISO 6149-2/-3

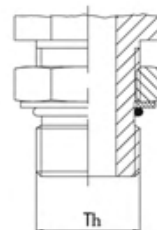

Raccordi Orientabili

Filettatura Metrica
ISO 6149-2/-3

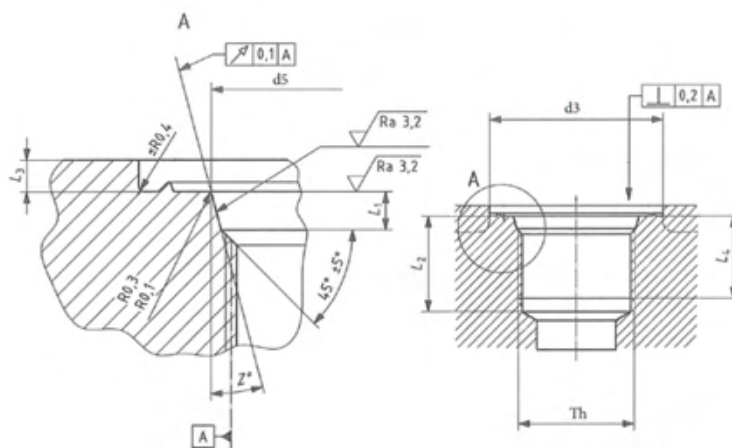

Bocche (Filettatura cilindrica)

Male Stud Metric Thread ISO 6149-1

Dimensions	[mm]								[degree]
Th	d ₂	d ₃ wide min.	d ₃ narrow min.	d ₅ +0,1	L ₃ max.	L ₁ +0,4	L ₂ min.	L ₄ min.	Z° +/-1°
M8x1	11,8	17	14	9,1	1	1,6	11,5	10	12
M10x1	13,8	20	16	11,1	1	1,6	11,5	10	12
M12x1,5	16,8	23	19	13,8	1,5	2,4	14	11,5	15
M14x1,5	18,8	25	21	15,8	1,5	2,4	14	11,5	15
M16x1,5	21,8	28	24	17,8	1,5	2,4	15,5	13	15
M18x1,5	23,8	30	26	19,8	2	2,4	17	14,5	15
M22x1,5	26,8	33	29	23,8	2	2,4	18	14,5	15
M27x1,5	31,8	40	34	29,4	2	3,1	22	19	15
M30x2	35,8	44	38	32,4	2	3,1	22	19	15
M33x1,5	40,8	49	43	35,4	2,5	3,1	22	19	15
M42x2	49,8	58	52	44,4	2,5	3,1	22,5	19,5	15

La tenuta è realizzata mediante O-Ring per i dritti e O-ring e rondella per gli orientabili.

Per le nuove progettazioni il comitato tecnico della ISO raccomanda l'utilizzo delle connessioni secondo ISO 6149.

DIMENSIONI PORTE E MASCHI DI ESTREMITA' FILETTATI

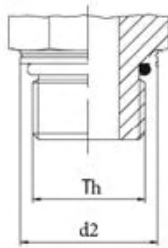

Raccordi Dritti

Filettatura UN/
UNF ISO 11926-2/-3

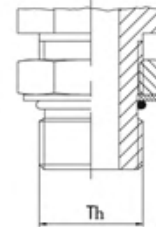

Raccordi Orientabili

Filettatura UN/UNF
ISO 11926-2/-3

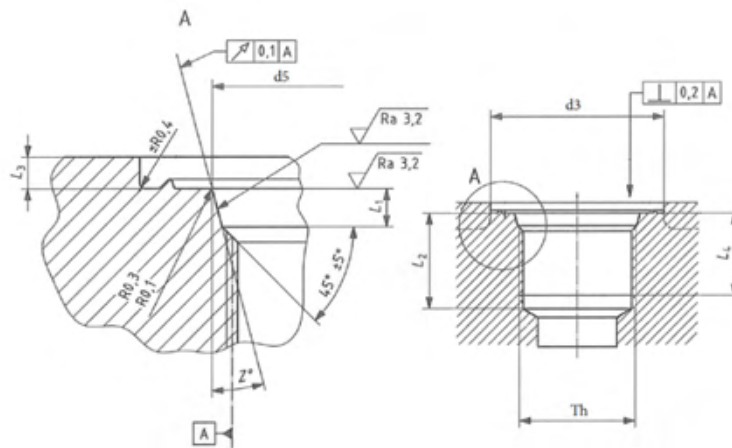

Bocche (Filettatura cilindrica)

Male Stud UN/UNF Thread ISO 11926-1 (SAE J1926-1)

Dimensions	[mm]							[degree]
Th	d ₂	d ₃ min.	d ₅ +/-0,05	L ₃ max.	L ₁ +0,4	L ₂ min.	L ₄ min.	Z° +/-1°
3/8-24 UNF-2A	11,8	19	10,75	1,6	1,9	12	10	12
7/16-20 UNF-2A	13,8	21	12,45	1,6	2,4	14	11,5	12
1/2-20 UNF-2A	16,8	23	14,05	1,6	2,4	14	11,5	12
9/16-18 UNF-2A	16,8	25	15,7	1,6	2,5	15,5	12,7	12
3/4-16 UNF-2A	21,8	30	20,65	2,4	2,5	17,5	14,3	15
7/8-14 UNF-2A	26,8	34	23,9	2,4	2,5	20	16,7	15
11/16-12 UN-2A	26,8	41	29,2	2,4	3,3	23	19	15
13/16-12 UN-2A	31,8	45	32,4	2,4	3,3	23	19	15
1 5/16-12 UN-2A	40,8	49	35,55	3,2	3,3	23	19	15
1 5/8-12 UN-2A	49,8	58	43,55	3,2	3,3	23	19	15
1 7/8-12 UN-2A	54,8	65	49,9	3,2	3,3	23	19	15

La tenuta è realizzata mediante O-Ring per i dritti e O-ring e rondella per gli orientabili.
Per le nuove progettazioni il comitato tecnico della ISO raccomanda l'utilizzo delle connessioni secondo ISO 6149.
I maschi di estremità conformi alla ISO 11926-3 e 11926-2, sono identici a quelli conformi rispettivamente alla SAE J514 e SAE J1453.

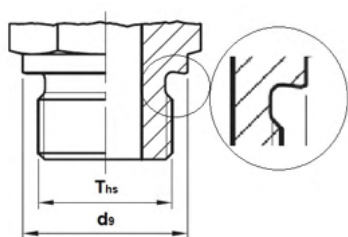

Tenuta faccia tagliente

Filettatura Metrica cilindrica
ISO 9974-3 (Type B)

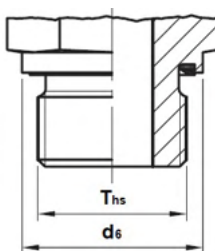

Tenuta con O-Ring

Filettatura metrica cilindrica
ISO 9974-2 (Type E)

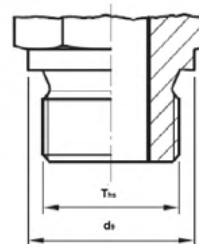

Tenuta: rondella DIN 7603 (es. rame)

Filettatura metrica cilindrica: DIN
3852-1 (Forma A)

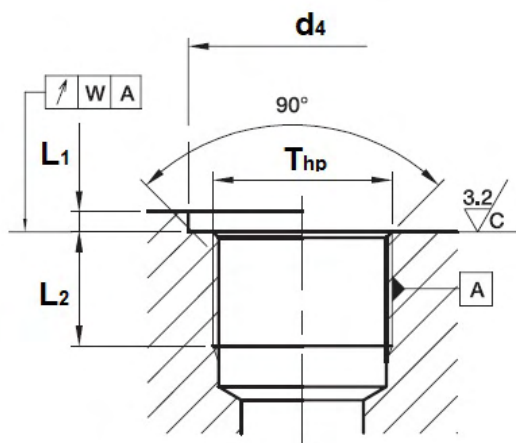

Bocche (Filettatura cilindrica)

Per maschio con filettatura metrica ISO 9974-1

Dimensions	[mm]					
T_{hp} / T_{hs}	d_e	d_s	$d_{4 \text{ min.}}$	$L_{1 \text{ max.}}$	$L_{2 \text{ min.}}$	W
M8 x 1	12	-	13	1	8	0,1
M10 x 1	14	13,9	15	1	8	
M12 x 1,5	17	16,9	18	1,5	12	
M14 x 1,5	19	18,9	20	1,5	12	
M16 x 1,5	21	21,9	23	1,5	12	
M18 x 1,5	23	23,9	25	2	12	
M20 x 1,5	25	25,9	27	2	14	
M22 x 1,5	27	26,9	28	2,5	14	0,2
M26 x 1,5	31	31,9	33	2,5	16	
M27 x 2	32	31,9	33	2,5	16	
M33 x 2	39	39,9	41	2,5	18	
M42 x 2	49	49,9	51	2,5	20	
M48 x 2	55	54,9	56	2,5	22	

La tenuta è realizzata mediante O-Ring per il Type E e tramite l'accoppiamento metallo-metallo per il Type B.

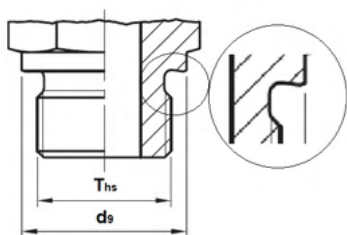

Tenuta faccia tagliente

**Filettatura BSPP ISO 1179-4
(Type B)**

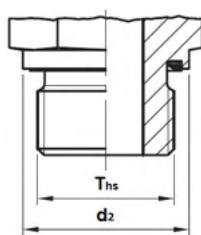

Tenuta con O-Ring

**Filettatura BSPP ISO 1179-2
(Type E)**

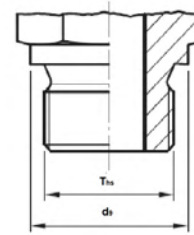

Tenuta: rondella DIN 7603 (es. rame)

**Filettatura BSPP: DIN 3852-2 (Form
A)**

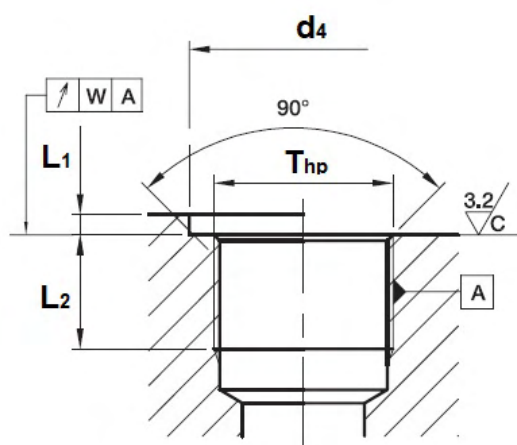

Bocche (Filettatura cilindrica)

Per maschio con filettatura BSPP ISO 1179-1

Dimensions	[mm]						
T_h	d_9	d_2	$d_{4 \text{ min.}}$	$d_{4 \text{ min. wide}}$	$L_{1 \text{ max.}}$	$L_{2 \text{ min.}}$	W
G 1/8 A	14	13,9	15	17,2	1	8,5	0,1
G 1/4 A	18	18,9	20	20,7	1,5	12,5	0,1
G 3/8 A	22	21,9	23	24,5	2	12,5	0,1
G 1/2 A	26	26,9	28	29,6	2,5	15	0,1
G 3/4 A	32	31,9	33	36,9	2,5	16,5	0,2
G 1 A	39	39,9	41	46,1	2,5	19	0,2
G 1 1/4 A	49	49,9	51	54	2,5	21,5	0,2
G 1 1/2 A	55	54,9	56	60,5	2,5	22,5	0,2

La tenuta è realizzata mediante O-Ring per il Type E e tramite l'accoppiamento metallo-metallo per il Type B.

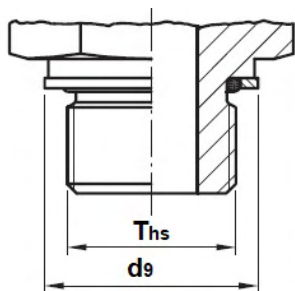

**Maschio dritto
Type G con anello
di ritegno**

Filettatura BSPP
ISO 1179-3

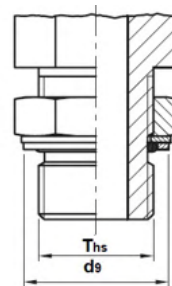

**Maschio girevole
Type H con anello di
ritegno**

Filettatura BSPP
ISO 1179-3

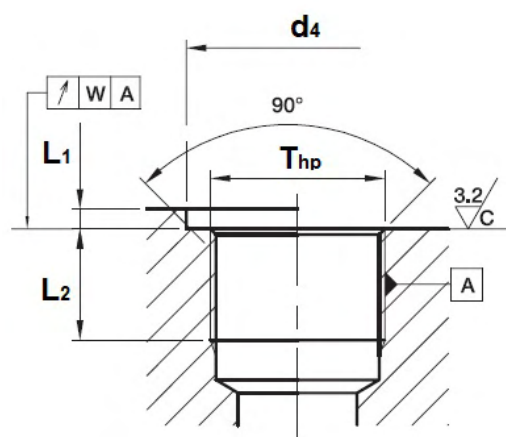

Bocche (Filettatura cilindrica)

Per maschio con filettatura GAS ISO 1179-1

Dimensions	[mm]					
T_h / T_{hs}	$d_9 \pm 0,1$	$d_4 \text{ min. narrow}$	$d_4 \text{ min. wide}$	$L_{1 \text{ max.}}$	$L_{2 \text{ min}}$	W
G 1/8 A	15	15	17,2	1	8,5	0,1
G 1/4 A	19,8	20	20,7	1,5	12,5	0,1
G 3/8 A	23,5	23	24,5	2	12,5	0,1
G 1/2 A	28,5	28	29,6	2,5	15	0,1
G 3/4 A	34,5	33	36,9	2,5	16,5	0,2
G 1 A	43,5	41	46,1	2,5	19	0,2
G 1 1/4 A	52,5	51	54	2,5	21,5	0,2
G 1 1/2 A	60	56	60,5	2,5	22,5	0,2

La tenuta è realizzata mediante O-Ring e anello di ritegno.

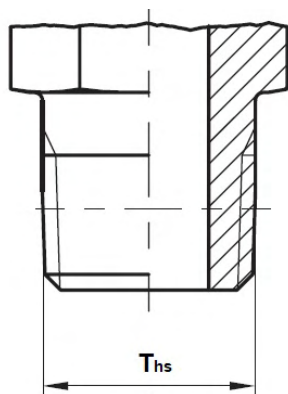

Maschio dritto
Filetto conico
NPT/NPTF

SAE J476 - ANSI/
 ASME B1.20.1 /
 ANSI /ASME B
 1.20.3

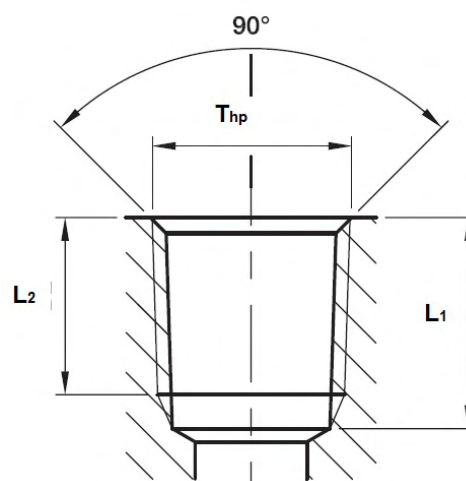

Bocche (Filettatura cilindrica)

Per maschio con filettatura conica

NPT /F

Dimensions	[mm]	
$T_{hs} - T_{hp}$	L_{1min}	L_{2min}
1/8-27 NPT/F	11,6	6,9
1/4-18 NPT/F	16,4	10,0
3/8-18 NPT/F	17,4	10,3
1/2-14 NPT/F	22,6	13,6
3/4-14 NPT/F	23,1	14,1
1-11 1/2 NPT/F	27,8	16,8
1.1/4"-11 1/2 NPT/F	28,3	17,3
1.1/2-11 1/2 NPT/F	28,3	17,3

La tenuta è realizzata mediante la filettatura. Risulta necessario utilizzare un materiale di tenuta.
 Sconsigliato per assemblaggi ripetitivi.
 Si raccomanda di non usare mai un maschio con filetto conico in una femmina con filetto cilindrico.

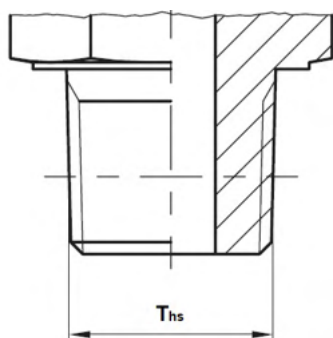

**Filetto conico
BSPT**

ISO 7/1 – BS 21

DIN 3852-2 (standard)

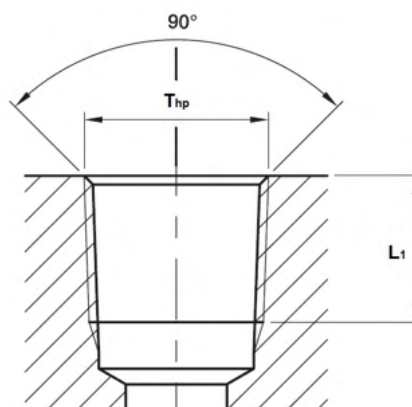

Bocche (Filettatura cilindrica)

Per maschio con filettatura conica

BSPT

Dimensions	[mm]	
T_{hs}	T_{hp}	L_{1min}
R 1/8-28	R 1/8	7,4
R 1/4-19	R 1/4	11,0
R 3/8-19	R 3/8	11,4
R 1/2-14	R 1/2	15,0
R 3/4-14	R 3/4	16,3
R 1-11	R 1	19,0
R 1 1/4-11	R 1 1/4	21,4
R 1 1/2 -11	R 1 1/2	21,4

La tenuta è realizzata mediante la filettatura. Sconsigliato per assemblaggi ripetitivi.

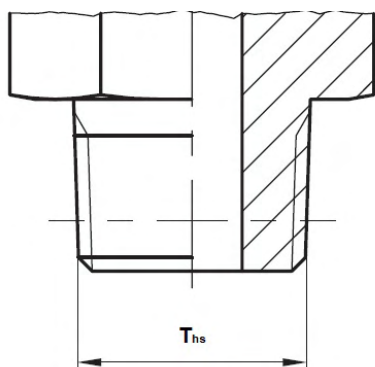

Filetto conico

Metrico DIN 3852-1

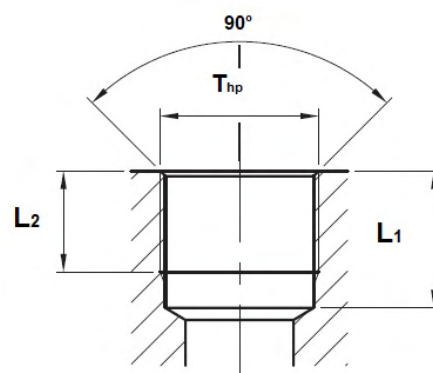

Bocche (Filettatura cilindrica)

Per maschio con filettatura conica metrica

Dimensions		[mm]	
T_{hs}	T_{hp}	$L_{1 \text{ min}}$	$L_{2 \text{ min}}$
M8 x 1 t.	M8 x 1	10,0	5,5
M10 x 1 t.	M10 x 1	10,0	5,5
M12 x 1,5 t.	M12 x 1,5	13,5	8,5
M14 x 1,5 t.	M14 x 1,5	13,5	8,5
M16 x 1,5 t.	M16 x 1,5	13,5	8,5
M18 x 1,5 t.	M18 x 1,5	13,5	8,5
M20 x 1,5 t.	M20 x 1,5	15,5	10,5
M22 x 1,5 t.	M22 x 1,5	15,5	10,5

La tenuta è realizzata mediante la filettatura. Sconsigliato per assemblaggi ripetitivi. Necessario l'uso di materiale di tenuta.

SCelta DELLA TUBAZIONE

Nella progettazione e nella scelta di una tubazione vanno considerati i seguenti aspetti:

- Definizione del diametro interno;
- Definizione dello spessore.

Di seguito si riporta il normogramma e la tabella di riferimento per le pressioni di lavoro del tubo secondo la DIN 2413 e la ISO 10763.

Velocità consigliate:

Linee di pressione: 3 - 8 m/s

Linee di ritorno: 1,5 - 3 m/s

Linee di aspirazione: 0,5 - 1,5 m/s

Linee di pilotaggio: max 5 m/s

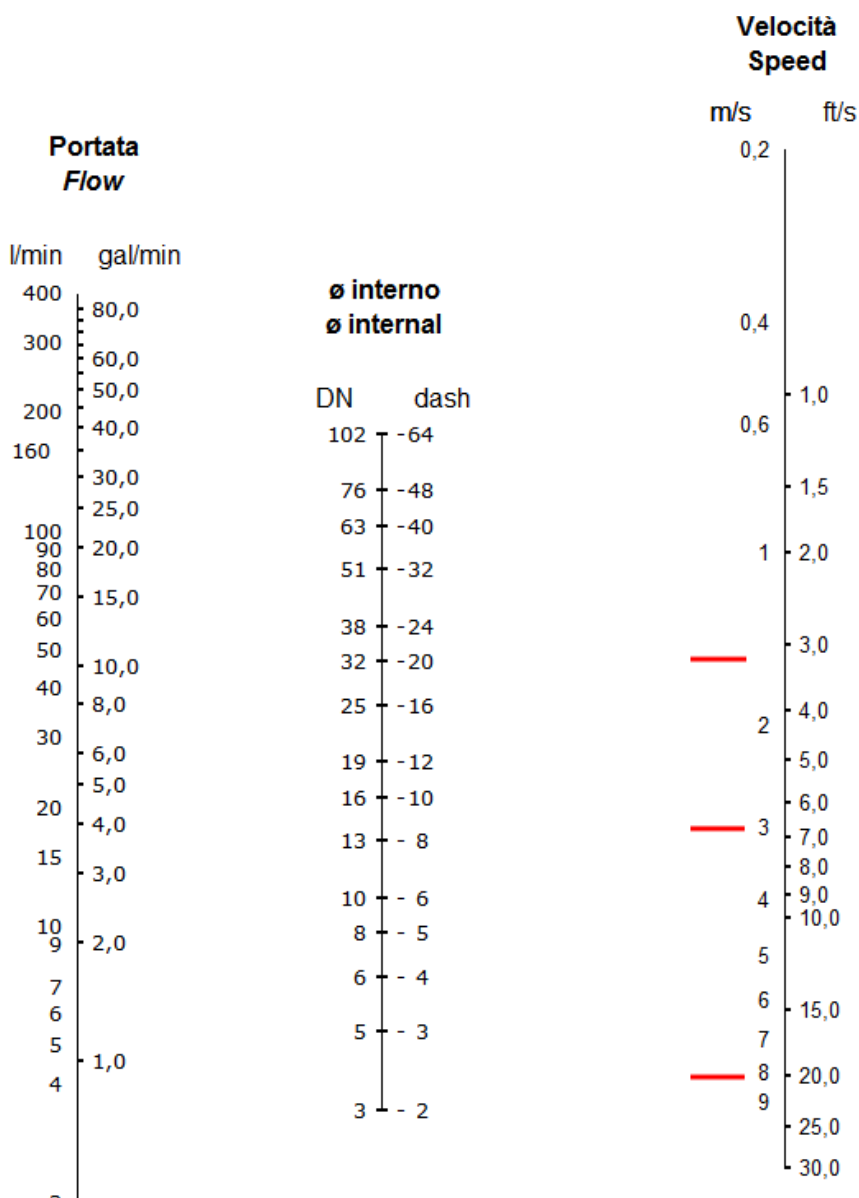

PRESSIONE DI PROGETTO / DI SCOPPIO CALCOLATA DEL TUBO

Tube OD [mm]	TUBE ID [mm]	Wall thk [mm]	Working pressure calculated [bar] iaw DIN 2413 – Load configuration I (static loads up to 120°C)		Working pressure calculated [bar] iaw DIN 2413 – Load configuration III (dynamic loads up to 120°C)		Burst pressure [bar] iaw ISO 10763	
			Material E235+N	Material E355	Material E235+N	Material E355	Material E235+N	Material E355
6	4,5	0,75	338	491	303	310	1116	1525
6	4	1	450	655	391	400	1573	2149
6	3	1,5	675	983	551	563	2689	3674
6*	2	2	900	1310	692	708	4263	5823
6*	1,5	2,25	1013	1474	757	774	5379	7347
8	6	1	338	491	303	310	1116	1525
8	5	1,5	506	737	433	443	1824	2491
8	4	2	675	983	551	563	2689	3674
8*	3	2,5	844	1228	659	673	3806	5198
10	8	1	270	393	248	253	866	1183
10	7	1,5	405	590	357	365	1384	1890
10	6	2	540	786	458	468	1982	2707
10	5	2,5	675	983	551	563	2689	3674
10*	4	3	810	1179	638	652	3555	4856
12	10	1	225	328	209	214	707	966
12	9	1,5	338	491	303	310	1116	1525
12	8	2	450	655	391	400	1573	2149
12	7	2,5	563	819	474	484	2091	2857
12	6	3	675	983	551	563	2689	3674
12*	5	3,5	823	1180	624	638	3397	4640
12*	4	4	940	1348	692	708	4263	5823
14	12	1	193	281	181	185	598	817
14	11	1,5	289	421	264	270	936	1278
14	10	2	386	561	342	349	1306	1783
14	9	2,5	482	702	415	425	1714	2342
14	8	3	579	842	485	496	2171	2966
14	7	3,5	705	1011	551	563	2689	3674
15	13	1	180	262	170	174	555	758
15	12	1,5	270	393	248	253	866	1183
15	11	2	360	524	321	329	1203	1644
15	10	2,5	450	655	391	400	1573	2149
15	9	3	540	786	458	468	1982	2707
16	14	1	169	246	160	163	518	708
16	13	1,5	253	368	233	239	806	1100
16	12	2	338	491	303	310	1116	1525
16	11	2,5	422	614	370	378	1454	1986
16	10	3	506	737	433	443	1824	2491
16	8	4	705	1011	551	563	2689	3674
18	16	1	150	218	143	146	457	624
18	15	1,5	225	328	209	214	707	966
18	14	2	300	437	273	279	975	1332
18	13	2,5	375	546	333	341	1263	1725
18	12	3	450	655	391	400	1573	2149
18	10	4	627	899	500	511	2281	3115
20	17	1,5	203	295	190	194	631	861
20	16	2	270	393	248	253	866	1183
20	15	2,5	338	491	303	310	1116	1525
20	14	3	405	590	357	365	1384	1890
20	13	3,5	494	708	408	417	1671	2283
20	12	4	564	809	458	468	1982	2707
20	10	5	705	1011	551	563	2689	3674

PRESSIONE DI PROGETTO / DI SCOPPIO CALCOLATA DEL TUBO

Tube OD [mm]	TUBE ID [mm]	Wall thk [mm]	Working pressure calculated [bar] iaw DIN 2413 – Load configuration I (static loads up to 120°C)		Working pressure calculated [bar] iaw DIN 2413 – Load configuration III (dynamic loads up to 120°C)		Burst pressure [bar] iaw ISO 10763	
			Material E235+N	Material E355	Material E235+N	Material E355	Material E235+N	Material E355
22	20	1	123	179	118	121	370	505
22	19	1,5	184	268	173	177	569	777
22	18	2	245	357	227	232	779	1064
22	17	2,5	307	447	278	285	1000	1366
22	16	3	368	536	328	335	1236	1688
22	15	3,5	449	643	376	384	1486	2030
22	14	4	513	735	422	431	1754	2396
25	22	1,5	162	236	154	157	496	678
25	21	2	216	314	201	206	676	924
25	20	2,5	270	393	248	253	866	1183
25	19	3	324	472	292	299	1065	1455
25	18	3,5	395	566	336	343	1275	1741
25	17	4	451	647	378	386	1496	2044
25	16	4,5	508	728	418	428	1732	2365
25	15	5	564	809	458	468	1982	2707
28	25	1,5	145	211	138	141	440	601
28	24	2	193	281	181	185	598	817
28	23	2,5	241	351	223	228	763	1043
28	22	3	289	421	264	270	936	1278
28	21	3,5	353	506	303	310	1116	1525
28	20	4	403	578	342	349	1306	1783
30	26	2	180	262	170	174	555	758
30	25	2,5	225	328	209	214	707	966
30	24	3	270	393	248	253	866	1183
30	23	3,5	329	472	285	291	1031	1408
30	22	4	376	539	321	329	1203	1644
30	20	5	470	674	391	400	1573	2149
30	18	6	564	809	458	468	1982	2707
35	32	1,5	121	173	111	114	348	475
35	31	2	161	231	147	150	471	643
35	30	2,5	201	289	181	185	598	817
35	29	3	242	347	215	220	730	997
35	27	4	322	462	280	286	1007	1375
35	25	5	403	578	342	349	1306	1783
38	34	2	148	213	136	139	432	589
38	33	2,5	186	266	168	171	547	748
38	32	3	223	319	199	203	667	911
38	30	4	297	426	260	265	917	1253
38	28	5	371	532	318	325	1185	1619
38	26	6	445	639	373	382	1472	2011
38	24	7	519	745	427	436	1783	2436
38	22	8	594	851	478	488	2121	2897
42	39	1,5	101	144	93	96	288	393
42	38	2	134	193	123	126	388	530
42	37	2,5	168	241	153	156	492	672
42	36	3	201	289	181	185	598	817
42	34	4	269	385	237	242	820	1120
42	32	5	336	481	290	297	1041	1441

ISTRUZIONI DI ASSEMBLAGGIO

ISO 8434-1/DIN2353 – Istruzioni di Assemblaggio

1. Preparazione del tubo

- Tagliare il tubo con il corretto angolo. È permessa una deviazione massima di $0,5^\circ$ rispetto all'asse del tubo

NOTA

Non usare taglia-tubi o dischi taglienti in quanto potrebbero causare eccessive bave e danneggiare il tubo. È raccomandato l'uso di macchine o attrezzature per un taglio di precisione.

- Sbavare leggermente i bordi del tubo internamente ed esternamente (massimo $0,2 \times 45^\circ$) e rimuovere ogni traccia di lavorazione o residuo

NOTA

I tubi con spessore a parete sottile possono richiedere inserti di supporto. Deformazioni e/o irregolarità come tagli inclinati o bave eccessive possono ridurre l'integrità, la vita e la resistenza alla tenuta della connessione.

2. Lubrificazione e orientamento:

- Lubrificare il filetto e il cono del corpo e il filetto del dado.

- Posizionare il dado e l'anello tagliente sul tubo con il tagliente rivolto verso l'estremità del tubo.

NOTA: Per evitare problemi di assemblaggio l'anello tagliente va montato nella giusta direzione.

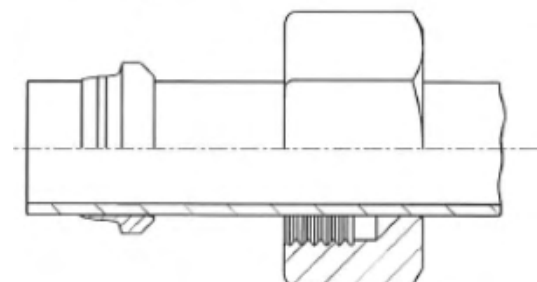
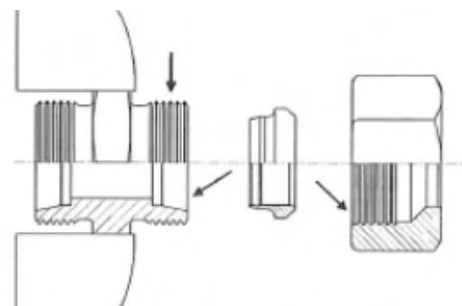
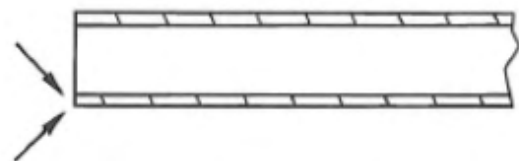
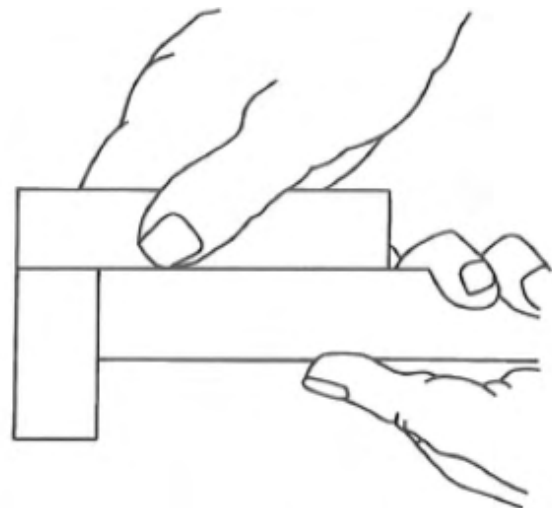

3. Assemblaggio iniziale:

- Stringere il dado a mano finché non si senta chiara la resistenza dovuta al contatto tra corpo, anello tagliente e dado.
- Spingere il tubo nella tasca del raccordo finché non viene assicurato il contatto con il ferma-tubo. Questo assicura che l'anello tagliente incida il tubo correttamente.

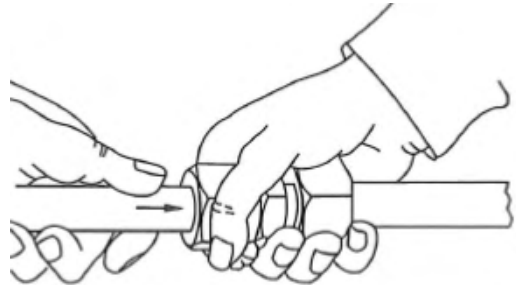

4. Montaggio: Pre-Montaggio:

- Dopo aver spinto il tubo nella tasca del raccordo avvitare il dado a mano finché l'anello resti fermamente nel dado.
- Avvitare in seguito con una chiave fino a che l'anello interferisca con il tubo e ne prevenga la rotazione.
- Avvitare quindi il dado fino ad un massimo di 1 giro mantenendo il tubo ed evitando che ruoti.

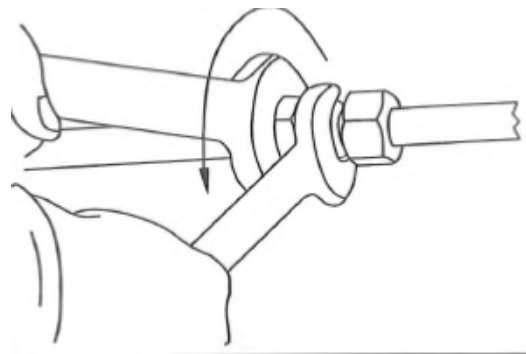

Per una connessione più affidabile utilizzare la macchina HF3-DIN



Per il Pre-assemblaggio manuale utilizzare il BOX-DIN-M



5. Verifica

- Disassemblare la connessione.
- Verificare la penetrazione dell'anello tagliente sul tubo. Se la connessione è stata effettuata correttamente un anello di materiale uniformemente distribuito sarà visibile sull'anello tagliente.

NOTA

L'anello tagliente può ruotare sul tubo ma non dovrebbe essere capace di movimenti assiali.

6. Montaggio o ri-assemblaggio:

- Nella fase di montaggio finale il dado va ri-assemblato fino a che sia evidente la resistenza al serraggio.
- Tenere il corpo fermo con una chiave e girare il dado con una seconda chiave.
- Il dado va ri-assemblato allo stesso serraggio dell'assemblaggio iniziale.
- Per tutti i pre-assemblati il dado va stretto con un ulteriore $\frac{1}{4}$ di giro dal momento in cui si incontra una chiara resistenza nel serraggio (si può arrivare fino ad un massimo di $\frac{1}{2}$ per il serraggio finale).

8. Lunghezza minima parte dritta tubo

- La lunghezza della parte non deformata del tubo deve essere almeno due volte l'altezza dell'esagono h ($L_{\min} = 2 \times h$)

NOTA

La parte dritta del tubo non deve presentare deviazioni rispetto alle tolleranze di ovalizzazione e linearità.

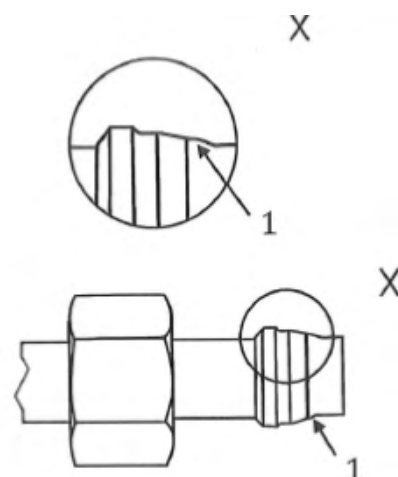

Key

1 ring of material

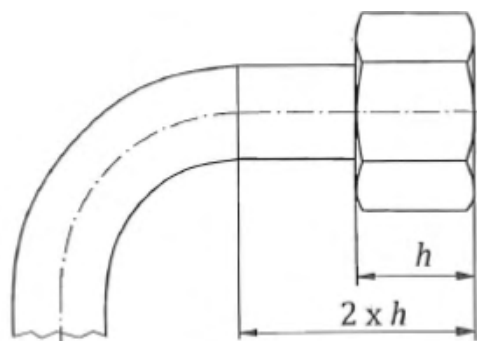
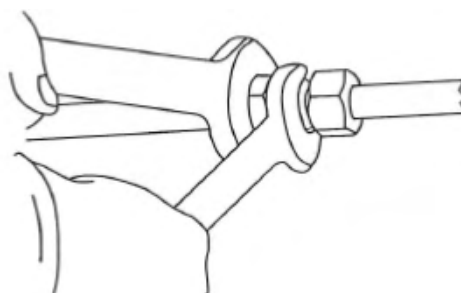

RACCORDI ORIENTABILI SENZA ANELLO DI RITEGNO

Istruzioni di Assemblaggio

ISO 6149, ISO 11926

1. Installazione

- Effettuare il pre-montaggio con contro dado, rondella e o-ring.
- Lubrificare l'o-ring.
- Liberare la sede del filetto avvitando il dado di bloccaggio.
- Installare il raccordo nella sede e verificare che la rondella tocchi la superficie della porta.

2. Orientamento

- Svitare il raccordo fino al massimo di 1 giro per orientarlo nella posizione desiderata.

4. Serraggio

- Serrare il controdado mantenendo il raccordo fisso con una chiave

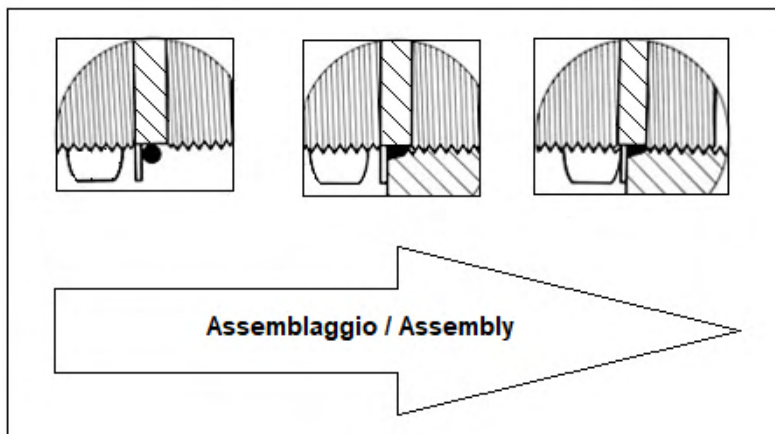
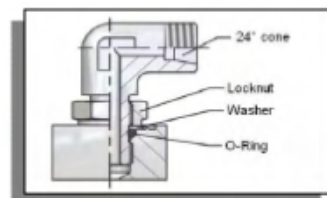
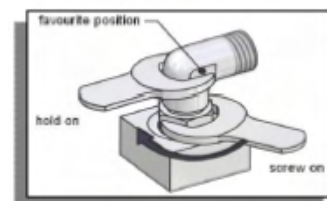
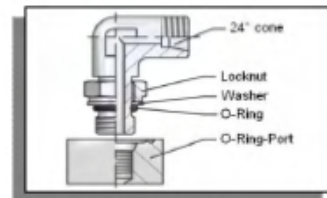

RACCORDI DKO

Istruzioni di Assemblaggio

ISO 8434-1

1. Assemblaggio

- Verificare che l'O-ring sia correttamente in sede e che non presenti segni di danneggiamento o irregolarità.
- Lubrificare leggermente il filetto, il cono e l'O-ring.
- Mantenere allineata il raccordo e inserirlo nel cono spingendolo con fermezza.
- Avvitare il dado serrandolo manualmente.
- Girare il dado di $\frac{1}{4}$ - $\frac{1}{3}$ di giro per completare l'assemblaggio

NOTE

- L'assemblaggio e il disassemblaggio vanno effettuati utilizzando due chiavi e girando il dado e non la controparte di connessione.

Key

- 1 body
- 2 nut
- 3 DKO-end (including O-ring)

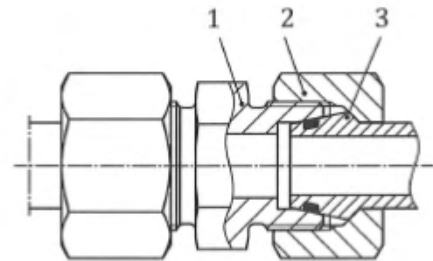

NIPPLI A SALDARE

Istruzioni di Assemblaggio

ISO 8434-1

1. Note generali

- La norma di riferimento è la ISO 8434-1.
- L'utilizzatore è responsabile per la saldatura.
- Le lunghezze di riferimento del tubo sono le seguenti:

Serie	OD Tubo [mm]	C1 [mm] [±1 mm]
L	6	32
	8	32
	10	33,5
	12	33,5
	15	35
	18	37
	22	39,5
	28	42,5
	35	49,5
	42	50
S	6	32
	8	32
	10	33,5
	12	33,5
	14	37
	16	40,5
	20	47
	25	53,5
	30	57,5
	38	64,5

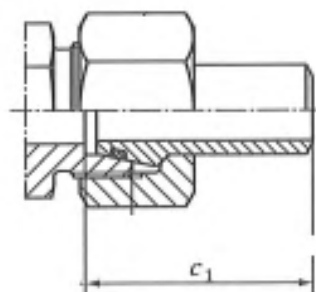

2. Assemblaggio

- Verificare che l'O-ring sia correttamente in sede e che non presenti segni di danneggiamento o irregolarità.
- Lubrificare leggermente il filetto, il cono e l'O-ring.
- Mantenere allineato il raccordo e inserirlo nel cono spingendolo con fermezza.
- Avvitare il dado serrandolo manualmente.
- Girare il dado di ¼ di giro per completare l'assemblaggio

NOTE

- L'assemblaggio e il disassemblaggio vanno effettuati utilizzando due chiavi e girando il dado e non la controparte di connessione.

DIMENSIONI TUBO PER RACCORDI JIC

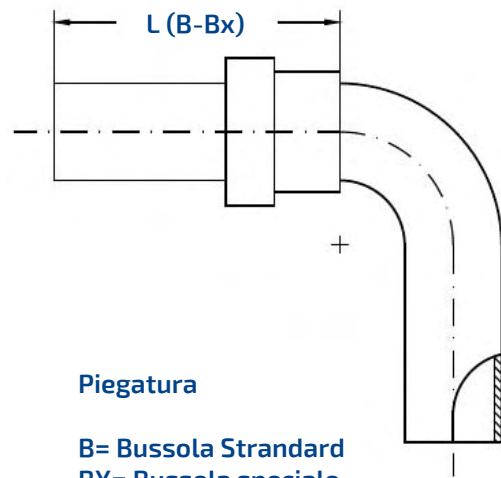
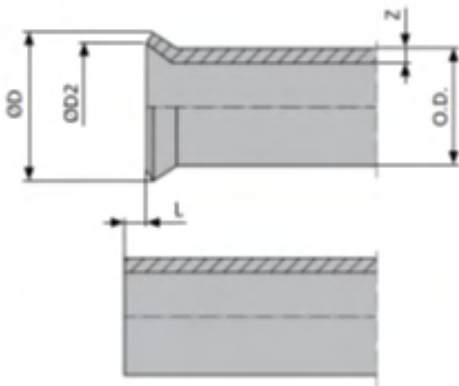

Tube OD		Flaring D max [mm]	Flaring D2 min. [mm]	Max. tube wall thickness Z [mm]	Length decrease L [mm]	L [mm]	
[mm]	[inch]					B	Bx
6	1/4	9,7	8,0	1,5	2,5	22	19
8	5/16	11,3	10,0	1,5	2,5	25	-
10	3/8	12,7	11,7	1,5	2,5	27	24
12	1/2	17,3	14,7	2,0	3,0	30	26
15	-	20,2	16,5	2,0	3,0	34	30
16	5/8	20,2	16,5	2,5	3,0	39	34
20	3/4	24,6	21,0	2,5	3,5	48	-
25	1	31,0	25,1	3,0	4,0	48	-
30	-	38,9	31,8	3,0	5,0	59	-
35	1 1/4'	38,9	31,8	3,0	5,0	64	-
38	1 1/2'	42,3	38,5	3,0	5,0	64	-
						70	-



DIMENSIONI TUBO PER RACCORDI ORFS

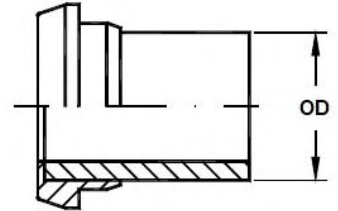
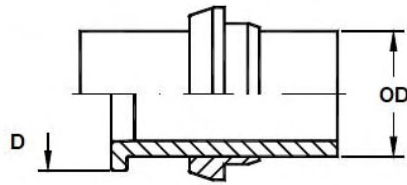
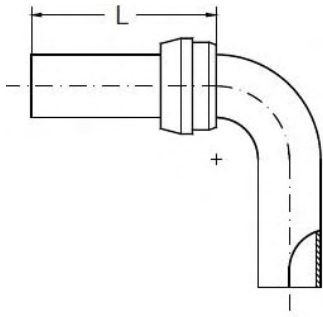

Piegatura

Deformazione Meccanica

Brasatura

Tube OD		D min [mm]	D max. [mm]	L min [mm]
[mm]	[inch]			
6	1/4	12,0	12,7	38,0
8	5/16	15,0	15,7	38,0
10	3/8	15,0	15,7	38,0
12	1/2	18,0	18,9	38,0
14	-	22,5	23,4	48,0
16	5/8	22,5	23,4	48,0
18	-	26,5	27,8	48,0
20	3/4	26,5	27,8	48,0
25	1	32,5	34,2	48,0
30	-	39,5	40,5	
35	1 1/4'	39,5	40,5	
38	1 1/2'	47,5	48,5	

PROGETTAZIONE E INSTALLAZIONE ASSEMBLATI

Per un corretto dimensionamento e per il calcolo della lunghezza del tubo richiesta per una data lunghezza di assemblato bisogna prendere in considerazione i seguenti fattori:

- Lunghezza minima delle parti dritte e delle parti curve;
- Dimensioni aggiuntive nelle parti di connessione;
- Sezioni di tubo aggiuntive (cartellature, raggi di curvatura, lunghezza delle curve, sezioni dritte).

Come linea generale è consigliabile nella fase di progettazione considerare una lunghezza extra per le estremità del tubo. Questo permette di poter effettuare gli adeguamenti necessari prima di effettuare le operazioni di pre-montaggio e assemblaggio.

Si riporta di seguito come riferimento le dimensioni della tasca secondo ISO 8434-1:

Tube OD	T5 [mm]
L 6	7
L 8	7
L 10	7
L 12	7
L 15	7
L 18	7,5
L 22	7,5
L 28	7,5
L 35	10,5
L 42	11
S 6	7
S 8	7
S 10	7,5
S 12	7,5
S 14	8
S 16	8,5
S 20	10,5
S 25	12
S 30	13,5
S 38	16

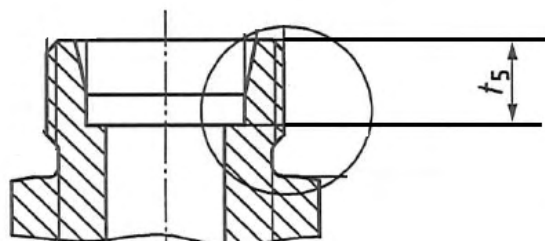

RACCOMANDAZIONI

Nei sistemi idraulici è necessario garantire una corretta costruzione delle linee rigide e dei relativi raccordi. Risulta infatti necessario avere un funzionamento efficiente dell'impianto senza perdite o fallimenti.

Dopo aver dimensionato le linee di tubi, si elencano alcune raccomandazioni da seguire nell'installazione e nel montaggio:

Accessibilità: si consiglia di tenere le linee dei tubi lontani dai componenti che richiedono manutenzione periodica e di facilitare l'accesso ai punti di connessione dove è richiesta una ispezione periodica.

Disposizione: la disposizione delle linee deve poter garantire la manutenzione e la riparazione. Si raccomanda di avere linee ad angolo retto, parallele tra loro e facilmente accessibili.

Fissaggio: non utilizzare linee di tubo per supportare carichi. Si raccomanda di fissare i tubi su punti fermi con adeguati collari.

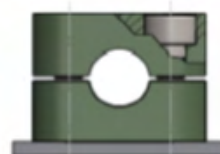

Lunghezza: si raccomanda di evitare tratti di tubo troppo corti per evitare rotture a fatica. Dove possibile si suggerisce di usare raccordi girevoli.

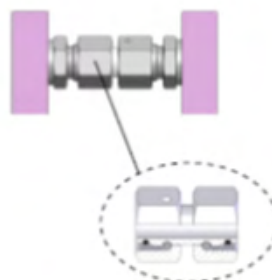
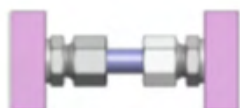

Installazione: si raccomanda di evitare eccessive tensioni sui raccordi che potrebbero creare perdite.



Staffe - Istruzioni per il montaggio

MONTAGGIO PIASTRA A SALDARE

- Posizionare la piastra inferiore della staffa nella posizione prescelta della struttura o del supporto e bloccarla con un magnete o con un'appropriata attrezzatura.
- Saldare quindi la piastra.
- Inserire un semi-collare nella piastra saldata, posizionare il tubo.
- Mettere il secondo semi-collare (ed eventualmente anche la piastra superiore) e fissare il tutto con le viti.

Non saldare la piastra inferiore con il semi-collare di plastica montato. Attenzione agli interessi dei tubi. Si sconsiglia il contatto tra due staffe.

MONTAGGIO BINARIO

I binari vengono forniti nella lunghezza di 2 metri. Saldare o avvitare il binario sul supporto o sulla struttura prescelta.

Inserire il dado esagonale scorrevole nel binario e girarlo leggermente in modo che non possa ruotare.

Inserire il semi-collare inferiore della staffa, posizionare il tubo, applicare il semi-collare superiore (ed eventualmente anche la piastra superiore) e fissare il tutto con le viti.

Attenzione agli interessi dei tubi. Si sconsiglia il contatto tra due staffe.

Ø esterno tubo - Ø tube (mm)	D (mt)
from 6 to 12,7	0,9
from 15 to 22	1,2
from 23 to 28	1,5
from 30 to 38,1	2
from 40 to 48,3	2,5
from 50 to 57	3
from 60 to 70	3,4
from 76,1 to 88,9	3,7
from 101,6 to 108	4
from 114,3 to 133	4,3
from 139,7 to 165,1	5
from 168,3 to 324	5,5

Distanza suggerita tra collari dello stesso tipo

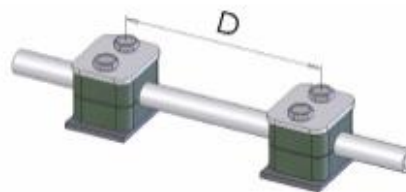

Si consiglia di posizionare le staffe prima e dopo una curva a 90.



GUARNIZIONI ELASTOMERICHE

Normalmente gli O-Ring presenti sui raccordi IMM sono costruiti in NBR con una durezza di 90 Shore A.

Tali guarnizioni sono adatte a lavorare in un range di temperatura compresa tra i -35 °C to +100 °C / -31 °F to +212 °F.

In caso di ambienti particolarmente aggressivi in termini di compatibilità e temperature sono disponibili anche guarnizioni in FKM (Viton®) con un range di temperatura di -25 °C to +200 °C / -13 °F to +392 °F ed EPDM.

Si raccomanda di seguire le indicazioni di stoccaggio definite dalla norma DIN 7716 come da tabella

I PRINCIPI DEL CORRETTO STOCCAGGIO

Gli O-Ring devono essere conservati in modo tale da evitare danneggiamenti esterni che possono presentarsi come danni superficiali dovuti a deformazioni per trazione, pressione o deformazione di curvatura oppure da componenti per imballo (es. graffette).

Gli O-ring devono inoltre essere conservati in un ambiente fresco e asciutto, possibilmente a temperature comprese tra 15°C e 25°C con umidità relativa inferiore al 65%

Non devono essere esposti troppo a lungo alla luce del sole ed alla luce artificiale con un elevato contenuto di UV e devono essere tenuti lontani dalle fonti di ozono.

I locali di deposito non devono contenere ozono che può essere prodotto da dispositivi come i motori elettrici, dispositivi ad alta tensione e non devono essere presenti, inoltre, gas di combustione ed organici.

Il contatto tra prodotti in gomma di composizioni diverse deve essere evitato. Così come il contatto con prodotti chimici e/o metalli pericolosi (per esempio rame, manganese) è da evitare.

La soluzione migliore consiste nel conservare gli O-ring in confezionamenti ermetici, in particolare sacchetti di plastica, protetti dai raggi UV.

Gli O-ring conservano le loro proprietà solo se conservati correttamente.

Se le suddette raccomandazioni sono rispettate, le guarnizioni possono essere conservate senza perdere le loro caratteristiche per un periodo di 5 anni per l'NBR e 10 anni per l'FKM.

Gli elastomeri insaturi, come la gomma nitrilica (NBR) possono avere età molto più breve in condizioni di conservazione improprie rispetto, per esempio ad elastomeri saturi, come il Fluoroelastomero (FKM).

Per assicurare la loro funzione di tenuta lo stoccaggio, la pulizia e la manutenzione devono rispettare le direttive della norma DIN 7716.

Il risultato è una vita utile più lunga e si eviteranno l'invecchiamento precoce, l'indurimento o l'infragilimento.

TABELLA DI COMPATIBILITA' DEI FLUIDI

Legenda		Guida ai materiali		
eccellente	↑	NBR	Gomma Nitrilica	
buono (OK per tenute statiche)	↗	EPDM	Etilen-Propilene	
discutibile (talvolta OK per tenute statiche)	→	FKM	Fluoroelastomero (Viton)	
scarso	↓			
Fluidi		NBR	FKM	EPDM
Acqua di mare (salata)		↑	↑	↗
Acqua potabile		↑	↑	↑
Aria 0-90 °C		↑	↑	↑
Aria 150-200 °C		↓	↑	↓
Aria 200-260 °C		↓	→	↓
Aria 90-150 °C		→	↑	↗
ASTM olio, n. 1		↑	↑	↓
ASTM olio, n. 2		↑	↑	↓
ASTM olio, n. 3		↑	↑	↓
ASTM olio, n. 4		↗	↑	↓
ASTM olio, n. 5		↑	↑	↓
Azoto		↑	↑	↑
Benzene		↓	↑	↓
Cherosene (simile a RP-1 e JP-1)		↑	↑	↓
Etanolo		↑	→	↑
Eteri		↓	↓	→
Fluido Freno DOT3 (tipo glicole)		→	↓	↑
Fluido idraulico biodegradabile HEES (Synthetic ester base)		↗	↑	↓
Fluido idraulico biodegradabile HETG (Triglycerides)		↗	↑	↓
Fluido idraulico biodegradabile HEPG (Polyalkyleneglycol base)		↗	↓	↓
Fluido idraulico biodegradabile HEPR (Other Base Liquid – primarily Polyalphaolefins)		↗	↑	↓
Gas naturale		↑	↑	↓
Gasolio		↑	↑	↓
Glicole etilenico		↑	↑	↑
Liquido freni auto		→	↓	↑
Metano		↑	↑	↓
Metanolo		↗	↓	↑
Oli idraulici (base sintetica)		↗	↑	↓
Oli lubrificanti (a base petrolio)		↑	↑	↓
Oli lubrificanti (a base sintetica)		↑	↑	
Oli lubrificanti (grezzi e raffinati)		↗	↑	↓
Oli minerali		↑	↑	↓
Oli motori		↑	↑	↓
Olio di petrolio greggio		↑	↑	↓
Olio idraulico (base di petrolio, industriale)		↑	↑	↓
Olio turbina		↑	↑	↓
Oli di silicone		↑	↑	↑
Vapore sotto i 200 °C		↓	↓	↑
Vapore, 200-260 °C		↓	↓	→

La suddetta tabella di compatibilità dei fluidi, fa riferimento a dati di letteratura; per maggiori informazioni, contattare l'ufficio tecnico.

Per adattatori e raccordi a pressione che presentano internamente l'o-ring, a contatto con il fluido, bisogna tener conto della compatibilità chimica con il fluido di passaggio che verrà utilizzato.

SOSTITUZIONE O'RING

Per la sostituzione dell'o-ring è necessario osservare i seguenti punti:

- Controllare gli elastomeri prima del montaggio e verificare che: non siano danneggiati in superficie; deformati; che non siano induriti; che non abbiano perso la loro elasticità.
- Usare grassi o oli da montaggio (compatibili con l'elastomero)
- Evitare la torsione da avvolgimento dell'O-ring
- Nella zona di montaggio dell'O-ring non devono essere presenti passaggi acuminati, solchi di lavorazione, filettature o fori
- Non è ammessa la presenza di sporcizia o di altri residui nella sede di installazione dell'O-ring

COPPIE DI SERRAGGIO

Dado su Tubo

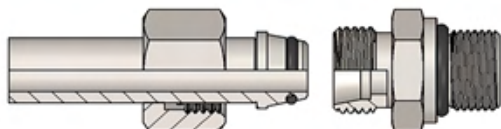

OD	T_h Metrico Serie Leggera (L)	N/m_0 +10%
6	M12x1,5	20
8	M14x1,5	30
10	M16x1,5	40
12	M18x1,5	50
15	M22x1,5	70
18	M26x1,5	90
22	M30x2	120
28	M36x2	160
35	M45x2	250
42	M52x2	380

OD	T_h Metrico Serie Pesante (S)	N/m_0 +10%
6	M14x1,5	25
8	M16x1,5	40
10	M18x1,5	50
12	M20x1,5	60
14	M22x1,5	75
16	M24x1,5	85
20	M30x2	140
25	M36x2	190
30	M42x2	270
38	M52x2	400

Fiacordo Girevole

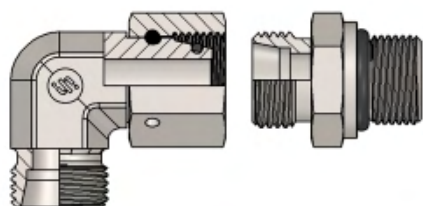

T_h Metrico Serie Leggera (L)	N/m_0 +10%
M12x1,5	20
M14x1,5	30
M16x1,5	40
M18x1,5	50
M22x1,5	70
M26x1,5	90
M30x2	120
M36x2	160
M45x2	250
M52x2	380

T_h Metrico Serie Pesante (S)	N/m_0 +10%
M14x1,5	25
M16x1,5	40
M18x1,5	50
M20x1,5	60
M22x1,5	75
M24x1,5	85
M30x2	140
M36x2	190
M42x2	270
M52x2	400

COPPIE DI SERRAGGIO

Dado su Tubo

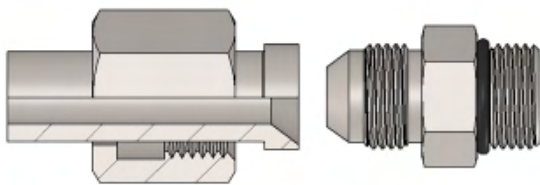

OD	JIC	N/m Min - Max
6	7/16" - 20	13 - 15
8	1/2" - 20	17 - 24
10	9/16" - 18	24 - 31
12	3/4" - 16	45 - 50
14÷16	7/8" - 14	65 - 70
18 - 20	1.1/16" - 12	90 - 95
25	1.5/16" - 12	120 - 140
30 - 32	1.5/8" - 12	170 - 185
38	1.7/8" - 12	210 - 230

Raccordo Girevole

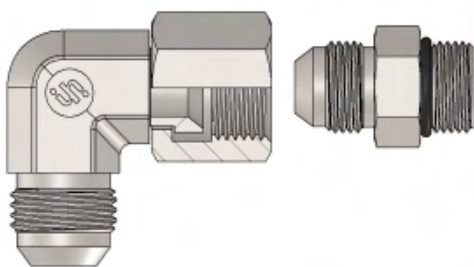

OD	JIC	N/m Max
6	7/16" - 20	15
8	1/2" - 20	25
10	9/16" - 18	31
12	3/4" - 16	52
14÷16	7/8" - 14	72
18 - 20	1.1/16" - 12	100
25	1.5/16" - 12	145
30 - 32	1.5/8" - 12	190
38	1.7/8" - 12	240

COPPIE DI SERRAGGIO

Dado su Tubo

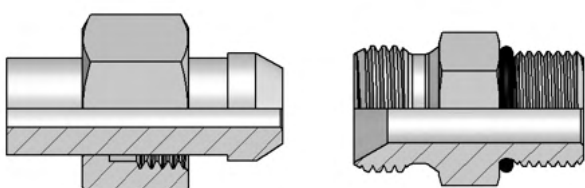

OD	BSP	N/m 0 +10%
6	1/8''	10
8	1/4''	20
10	3/8''	35
12	1/2''	60
16	5/8''	70
20	3/4''	115
25	1''	140
30	1 1/4''	210
38	1 1/2''	290

Raccordo Girevole

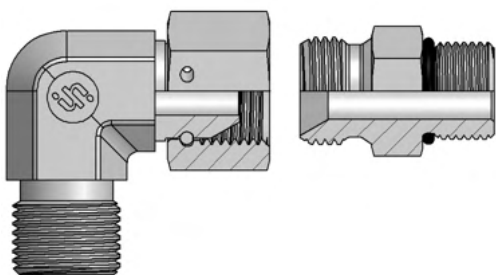

BSP	N/m 0 +10%
1/8''	13
1/4''	25
3/8''	45
1/2''	75
5/8''	85
3/4''	130
1''	160
1 1/4''	250
1 1/2''	330

COPPIE DI SERRAGGIO

Dado su Tubo

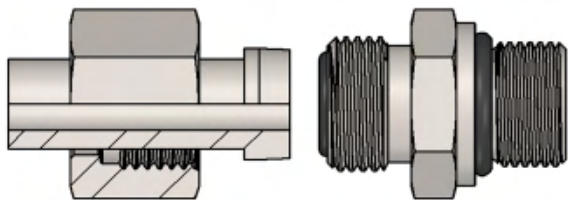

OD	T _h ORFS	N/m (0 +10 %)
6	9/16" - 18	25
8-10	11/16" - 16	40
12	13/16" - 16	55
14÷16	1" - 14	60
18-20	1.3/16" - 12	90
25	1.7/16" - 12	125
30-32	1.11/16" - 12	170
38	2" - 12	200

Raccordo Girevole

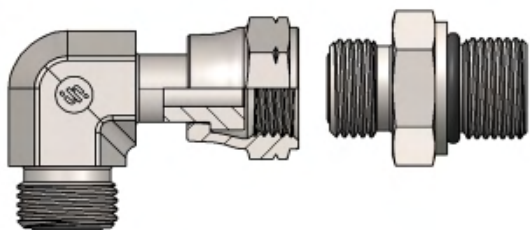

OD	T _h ORFS	N/m (0 +10 %)
6	9/16" - 18	28
8-10	11/16" - 16	45
12	13/16" - 16	60
14÷16	1" - 14	65
18-20	1.3/16" - 12	95
25	1.7/16" - 12	130
30-32	1.11/16" - 12	180
38	2" - 12	215

ASSEMBLAGGIO SU PORTE

Raccordo dritto e orientabile

ISO 11926 Non Adjustable			
Heavy Duty (S Series) ISO 11926-2		Light Duty (L Series) ISO 11926-3	
Thread Size UN / UNF	Torque N m (+10 % -0)	Thread Size UN / UNF	Torque N m (+10 % -0)
3/8-24	10	3/8-24	10
7/16-20	20	7/16-20	18
1/2-20	25	1/2-20	25
9/16-18	35	9/16-18	30
3/4-16	70	3/4-16	60
7/8-14	100	7/8-14	95
1 1/16-12	170	1 1/16-12	125
1 3/16-12	215	1 3/16-12	150
1 5/16-12	270	1 5/16-12	200
1 5/8-12	285	1 5/8-12	210
1 7/8-12	370	1 7/8-12	300

ISO 11926 Adjustable			
Heavy Duty (S Series) ISO 11926-2		Light Duty (L Series) ISO 11926-3	
Thread Size UN / UNF	Torque N m (+10 % -0)	Thread Size UN / UNF	Torque N m (+10 % -0)
3/8-24	10	3/8-24	10
7/16-20	20	7/16-20	18
1/2-20	25	1/2-20	25
9/16-18	35	9/16-18	30
3/4-16	70	3/4-16	60
7/8-14	100	7/8-14	95
1 1/16-12	170	1 1/16-12	125
1 3/16-12	215	1 3/16-12	150
1 5/16-12	270	1 5/16-12	200
1 5/8-12	285	1 5/8-12	210
1 7/8-12	370	1 7/8-12	300

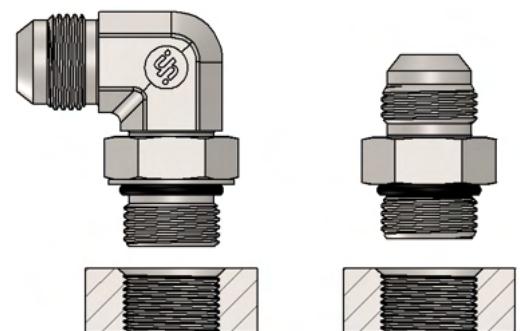

ASSEMBLAGGIO SU PORTE

ISO 1179					
Type E ISO 1179-2			Type B ISO 1179-4		
Series	BSPP Thread G Size	Torque N m (0 +10 %)	Series	BSPP Thread G Size	Torque N m (0 +10 %)
L	1/8	20	LL	1/8	15
	1/4	50	L	1/8	20
	3/8	80		1/4	40
	1/2	100		3/8	80
	3/4	200		1/2	150
	1	380		3/4	200
	1 1/4	500		1	380
	1 1/2	600		1 1/4	600
S	1/4	60		S	1 1/2
	3/8	90	1/4		60
	1/2	130	3/8		100
	3/4	200	1/2		170
	1	380	3/4		320
	1 1/4	500	1		380
	1 1/2	600	1 1/4		600
	2	650	1 1/2		800

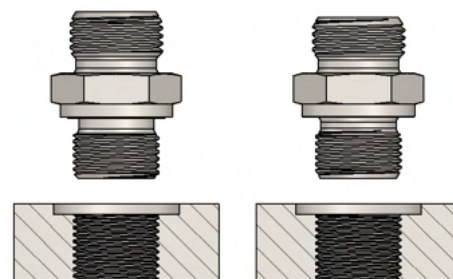

ISO 1179				
ISO 1179-3 Type H Adjustable			ISO 1179-3 Type G Non Adjustable	
Series	BSPP Thread H Size	Torque N m (0 +10 %)	BSPP Thread G Size	Torque N m (0 +10 %)
L	1/8	20	1/8	25
	1/4	50	1/4	50
	3/8	80	3/8	80
	1/2	100	1/2	105
	3/4	200	3/4	220
	1	370	1	370
	1 1/4	500	1 1/4	500
	1 1/2	600	1 1/2	600

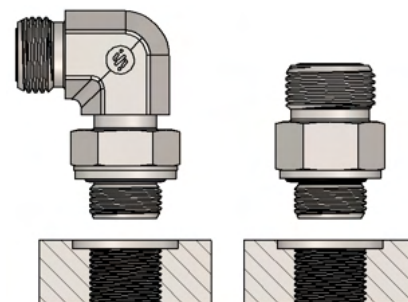

ASSEMBLAGGIO SU PORTE

Type E ISO 9974-2			Type B ISO 9974-3		
Series	BSPP Thread G Size	Torque N m (0 +10 %)	Series	Thread M Size	Torque N m (+10 % -0)
L	M10 x 1	20	LL	M8 x 1	10
	M12 x 1,5	30		M10 x 1	15
	M14 x 1,5	50	L	M10 x 1	20
	M16 x 1,5	60		M12 x 1,5	30
	M18 x 1,5	80		M14 x 1,5	50
	M22 x 1,5	140		M16 x 1,5	70
	M26 x 1,5	200		M18 x 1,5	90
	M33 x 2	380		M22 x 1,5	150
	M42 x 2	500		M26 x 1,5	210
	M48 x 2	600		M33 x 2	380
S	M12 x 1,5	45	M42 x 2	550	
	M14 x 1,5	60	M48 x 2	700	
	M16 x 1,5	80	S	M12 x 1,5	45
	M18 x 1,5	100		M14 x 1,5	60
	M20 x 1,5	140		M16 x 1,5	90
	M22 x 1,5	150		M18 x 1,5	120
	M27 x 2	200		M20 x 1,5	170
	M33 x 2	380		M22 x 1,5	190
	M42 x 2	500		M27 x 2	320
	M48 x 2	600		M33 x 2	450
			M42 x 2	600	
			M48 x 2	800	

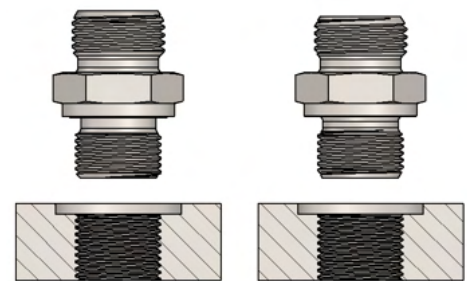

ASSEMBLAGGIO SU PORTE

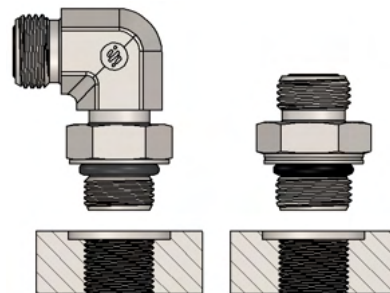
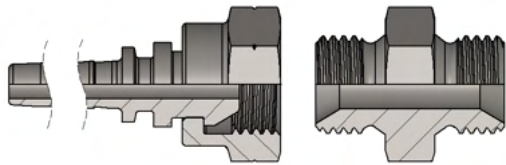

Type A DIN 3852-1		
Series	Thread M Size	Torque N m (+10 % -0)
L	M10 x 1	10
	M12 x 1,5	20
	M14 x 1,5	35
	M16 x 1,5	45
	M18 x 1,5	55
	M22 x 1,5	65
	M26 x 1,5	90
	M33 x 2	150
	M42 x 2	240
	M48 x 2	290
S	M12 x 1,5	20
	M14 x 1,5	35
	M16 x 1,5	45
	M18 x 1,5	55
	M20 x 1,5	60
	M22 x 1,5	65
	M27 x 2	90
	M33 x 2	150
	M42 x 2	240
	M48 x 2	290

ISO 6149			
ISO 6149-2 / -3			
Series	Thread M Size	Torque N m (0 +10 %)	
L	M8 x 1	8	
	M10 x 1	15	
	M12 x 1,5	25	
	M14 x 1,5	35	
	M16 x 1,5	40	
	M18 x 1,5	45	
	M22 x 1,5	60	
	M27 x 2	100	
	M30 x 2	130	
	M33 x 2	160	
	M42 x 2	210	
	M48 x 2	260	
	M60 x 2		
	S	M8 x 1	10
		M10 x 1	20
M12 x 1,5		35	
M14 x 1,5		45	
M16 x 1,5		55	
M18 x 1,5		70	
M22 x 1,5		100	
M27 x 2		170	
M30 x 2		215	
M33 x 2		310	
M42 x 2		330	
M48 x 2		420	
M60 x 2		500	

Diametri Filettature

Type	thread	dash	male (mm)		female (mm)	
			size	max	min	max
BSP	1/8-28	02	9,7	9,5	8,8	8,6
Metric	M10x1	10	9,9	9,8	9,1	8,9
UNF	7/16-20	04	11,0	10,9	10,0	9,7
Metric	M12x1,5	12	11,9	11,7	10,6	10,4
UNF	1/2-20	05	12,6	12,5	11,6	11,3
BSP	1/4-19	04	13,1	12,9	11,8	11,4
Metric	M14x1,5	14	13,9	13,7	12,6	12,4
UNF	9/16-18	06	14,2	14,0	13,0	12,8
UNF	5/8-18	07	15,8	15,6	14,6	14,4
Metric	M16x1,5	16	15,9	15,7	14,6	14,4
BSP	3/8-19	06	16,6	16,4	15,3	15,0
UN	11/16-16	09	17,4	17,2	16,1	15,7
Metric	M18x1,5	18	17,9	17,7	16,6	16,4
UNF	3/4-16	08	19,0	18,8	17,6	17,3
Metric	M20x1,5	20	19,9	19,7	18,6	18,4
UN	13/16-16	11	20,5	20,4	19,2	18,9
BSP	1/2-14	08	20,9	20,7	19,1	18,6
Metric	M22x1,5	22	21,9	21,7	20,6	20,4
UNF	7/8-14	10	22,1	21,9	20,6	20,3
BSP	5/8-14	10	22,9	22,6	21,1	20,6
UNS	1-14	13	25,3	25,1	23,8	23,4
Metric	M26x1,5	26	25,9	25,7	24,6	24,4
BSP	3/4-14	12	26,4	26,2	24,6	24,1
UN	1.1/16-12	12	26,9	26,7	25,1	24,7
Metric	M30x1,5	30	29,9	29,7	28,6	28,4
Metric	M30x2	30	29,9	29,7	28,2	27,8
UN	1.3/16-12	14	30,1	29,8	28,3	27,9
UN	1.5/16-12	16	33,2	33,0	31,4	31,0
BSP	1-11	16	33,2	32,9	30,9	30,3
Metric	M36x2	36	35,9	35,7	34,2	33,8
UN	1.7/16-12	15	36,4	36,2	34,6	34,2
Metric	M38x1,5	38	37,9	37,7	36,6	36,4
UN	1.5/8-12	20	41,2	40,9	39,4	39,0
BSP	1.1/4-11	20	41,9	41,6	39,5	39,0
Metric	M42x2	42	41,9	41,7	40,2	39,8
UN	1.11/16-12	21	42,8	42,5	41,0	40,6
Metric	M45x1,5	45	44,9	44,7	43,6	43,4
Metric	M45x2	45	44,9	44,7	43,2	42,8
UN	1.7/8-12	24	47,5	47,3	48,7	45,3
BSP	1.1/2-11	24	47,8	47,4	45,4	44,8
UN	2-12	32	50,7	50,5	48,9	48,5
Metric	M52x2	52	51,9	51,7	50,2	49,8
BSP	2-11	32	59,6	59,3	57,2	56,7
UN	2.1/2-12	32	63,4	63,2	61,6	61,2

Norme di Costruzione

Description	Standards
Gas / BSP	BS 5200 ; ISO 8434-6 ;
Metrico 24° / Metric 24°	DIN 3861; DIN 3865 ; ISO 8434-1 ; ISO 8434-4 ;
Metrico 60° / Metric 60°	DIN 7631; DIN 3863
ORFS	SAE J1453 ; ISO 8434-3 ;
NPT / NPTF	SAE J514
Jic 37°	SAE J514 ; ISO 8434-2 ;

Fattori di Conversione

unit	da	a	FRH®
	from	to	
lunghezza length	m metro meters	ft foot	3.281
lunghezza length	mm millimetro millimeters	n inch	0.03934
area	m ² metro quadro square meter	in ² square inch	1550
volume	l litro liters	gal gallon (UK)	0.264
peso mass	kg kilogrammo kilogramme	lb pound	2.205
coppia torque	N-m newton/metro newton/meters	lb/ft pound/foot	0.7374
velocità speed	m/s metro/secondo meters/second	ft/s feet per second	3.281
SRUWDWDÀRZ-UDWH	l/min litro per minuto/liters per minute	gal/min gallon per minute	0.264
pressione pressure	bar (105N/m ²)	psi pound/square inch	14.503
temperatura temperature	°C celsius	°F fahrenheit	°C(9/5)+32

METRIC TO PSI			
1 kPa = 0.145 psi			
bar	Mpa	kPa	psi
40	4	4000	580
50	5	5000	725
60	6	6000	870
70	7	7000	1015
80	8	8000	1160
90	9	9000	1305
100	10	10000	1450
200	20	20000	2900
300	30	30000	4350
400	40	40000	5800
500	50	50000	7250
600	60	60000	8700
700	70	70000	10150
800	80	80000	11600
900	90	90000	13050
1000	100	100000	14500
2000	200	200000	29000
3000	300	300000	43500

PSI TO METRIC			
1 kPa = 0.145 psi			
bar	Mpa	kPa	psi
40	4	4000	580
50	5	5000	725
60	6	6000	870
70	7	7000	1015
80	8	8000	1160
90	9	9000	1305
100	10	10000	1450
200	20	20000	2900
300	30	30000	4350
400	40	40000	5800
500	50	50000	7250
600	60	60000	8700
700	70	70000	10150
800	80	80000	11600
900	90	90000	13050
1000	100	100000	14500
2000	200	200000	29000
3000	300	300000	43500

STANDARD	Pressione Max di esercizio delle principali connessioni (design factor 4:1)						
ISO 8434-6		Thread Size	1/8	1/4		3/8	1/2
	BSP 60° cone with o-ring	MAX WP		400		400	350
	BSP 60° cone without o-ring	MAX WP	350	350		350	315
ISO 8434-2	37° Flared JIC	Thread size		7/16-20	1/2-20	9/16-18	3/4-16
		MAX WP		350	350	350	310
ISO 8434-3	O-ring face seal (ORFS)	Thread size		9/16-18	5/8-18	11/16-16	13/16-16
		MAX WP		630	630	630	630
ISO 8434-1	24° cone light series	Thread size	M12X1.5 (6L)	M14X1.5 (8L)	M16X1.5 (10L)	M18X1.5 (12L)	M22X1.5 (15L)
		MAX WP	415	400	350	330	275
	24° cone heavy series	Thread size	M16X1.5(8S)	M18X1.5 (10S)	M20X1.5 (12S)	M22X1.5 (14S)	M24X1.5 (16S)
		MAX WP	630	630	630	630	420
SAE J514	NPTF (dry seal pipe)	Thread size	1/8	1/4		3/8	1/2
		MAX WP	345	275		275	240
JIS B 8363	BSP 60° inverted cone (Toyota)	Thread size		1/4		3/8	1/2
		MAX WP		345		345	345
	BSP 60° inverted cone (Komatsu)	Thread size		M14X1.5	M16X1.5	M18X1.5	M22X1.5
		MAX WP		345	345	345	345

STANDARD	Pressione Max di esercizio delle principali connessioni (design factor 4:1)						
		Thread Size	3/4	1	1.1/4	1.1/2	1/2
	ISO 8434-6	BSP 60° cone with o-ring	MAX WP	315	250	200	160
		BSP 60° cone without o-ring	MAX WP	250	200	160	125
ISO 8434-2	37° Flared JIC	Thread size	1.1/16-12	1.5/16-12	1.5/8-12	1.7/8-12	3/4-16
		MAX WP	240	210	170	140	310
ISO 8434-3	O-ring face seal (ORFS)	Thread size	1.3/16-12	1.7/16-12	1.11/16-12	2-12	13/16-16
		MAX WP	400	400	250	250	630
	24° cone light series	Thread size	M30X2 (22L)	M36X2 (28L)	M45X2 (35L)	M52X2 (42L)	M22X1.5 (15L)
		ISO 8434-1	MAX WP	215	165	125	100
	24° cone heavy series	Thread size	M36X2 (255)	M42X2 (305)	M52X2 (385)		M24X1.5 (165)
		MAX WP	420	420	420		420
SAE J514	NPTF (dry seal pipe)	Thread size	3/4	1	1.1/4	1.1/2	1/2
		MAX WP	210	170	150	140	240
	BSP 60° inverted cone (Toyota)	Thread size	3/4	1	1.1/4	1.1/2	1/2
		JIS B 8363	MAX WP	275	205	170	105
	BSP 60° inverted cone (Ko- matsu)	Thread size	M30x1.5	M33X1.5	M36X1.5	M42X1.5	M22X1.5
		MAX WP	280	205	170	105	345

NORME DI RIFERIMENTO

ISO 8434-1 / -2 / -3 / -6

ISO 1179-1 / -2 / -3 / -4

ISO 6149-1 / -2 / -3 / -4

ISO 9974-1 / -2 / -3 / -4

ISO 11926-1 / -2 / -3

ISO 2230

DIN 3852-1/-2

DIN 2353

SAE J514

SAE J476

SAE J516

SAE J1926

ISO 261,

ISO 228/1

ISO 7/1

BS21

BS 2779

ANSI B1.20.3

ANSI B1.20.1

ANSI B1.1

ANSI B1.13M

ANSI B1.21.1

BSP

in!



1700



Union

6

1800



Male-Male Reducing

7

R605



Male-Female Reducing

8

2000

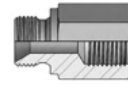

Male-Female Union

9

2010

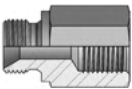

Male-Female Reducing

10

2020

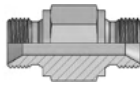

Union

11

A108

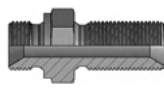

Bulkhead Union

12

A107



Bulkhead locknut

13

4520

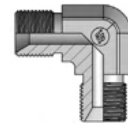

90° Elbow Union

14

4530



45° Elbow Union

15

4730

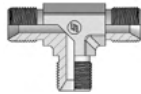

Union Tee

16

4900



Union Cross

17



4910



Union Cross

18



4700

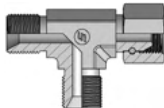

Run Tee Swivel Connector

19

4710

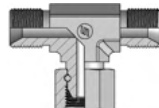

Branch Tee Swivel Connector

20

4800

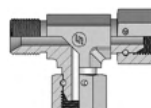

Run Tee Swivel Connector

21

4810

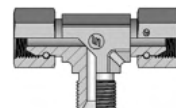

Branch Tee Swivel Connector

22

4720

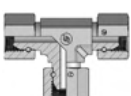

Union Tee

23

2350

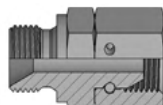

Swivel Connector

24

4500

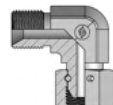

90° Swivel Elbow

25

4510



45° Swivel Elbow

26

3220

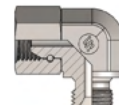

90° Comp. Swivel elbow

27

3320



45° Comp. Swivel elbow

28

2550

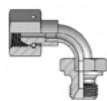

90° Welded Swivel Elbow

29

2650



45° Swivel Elbow

30

2450

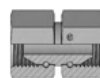

Swivel Connector

31

4550



90° Swivel Elbow

32

2750

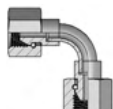

90° Welded Swivel Elbow

33

2850



45° Welded Swivel Elbow

34

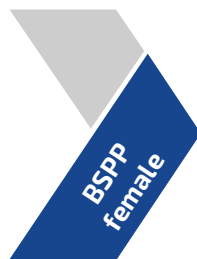

4570



90° Elbow Union

35

4820

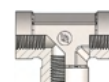

Union Tee

36

A105



Union

37

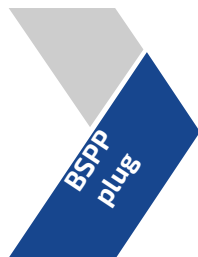

A608



Swivel Plug

38

A604



Female Plug

39

A605



Male Plug

40



MG



Male End

41

220C

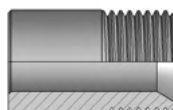

Male End

42

2200

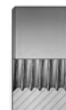

Threaded Sleeve

43



1865

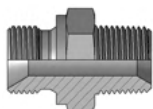

Male Connector

44

2360

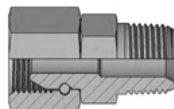

Swivel Connector

45

4860

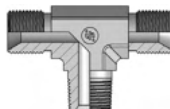

Branch Tee Connector

46

4620

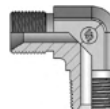

90° Elbow Connector

47

4630



45° Elbow Connector

48

4600

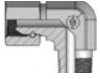

90° Swivel Elbow

49

4610



45° Swivel Elbow

50



1875

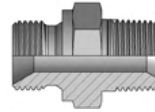

Male Connector

51

2365

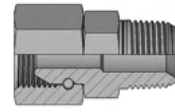

Swivel Connector

52

4870

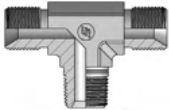

Branch Tee Connector

53

4670



90° Elbow Connector

54

4680



45° Elbow Connector

55

4650

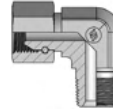

90° Swivel Elbow

56



1700E

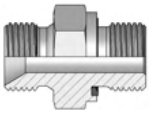

Male Connector (ED)

57

3900

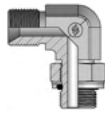

Adjustable 90° Elbow

58

3255

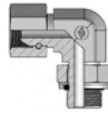

Adjustable 90° Elbow

59

3950



Adjustable 45° Elbow

60

3600

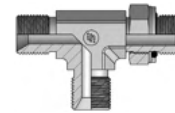

Adjustable Run Tee

61

3605



Adjustable Branch Tee

62



1805

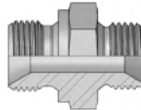

Male Connector

63

3510

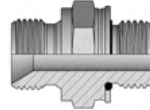

Male Connector

64

3910



Adjustable 90° Elbow

65

3410



Adjustable 45° Elbow

66

3610



Adjustable Run Tee

67

3615

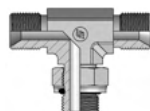

Adjustable Branch Tee

68

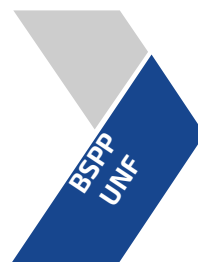

3520

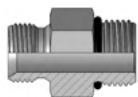

Male Connector

69

3920



Adjustable 90° Elbow

70

3420



Adjustable 45° Elbow

71

3620



Adjustable Run Tee

72

3625

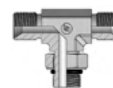

Adjustable Branch Tee

73



1550



BSP Threaded

74

1560



BSP Threaded

75

1450



Weldable BSP

76



1860

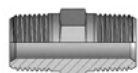

Male Union

77

4626



90° Elbow Union

78

4625



90° Elbow F BSPP

79

Unione diretto maschio BSP (ISO 8434-6)

S

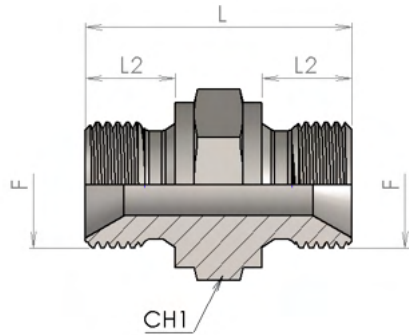

Part number	Dimensions						Weight kg/unit
	Ø		F	L	L2	CH1	
	tube mm	tube inch					
1700-02-02	6	1/4"	G 1/8	24.0	8.0	14	0.015
1700-04-04	8	5/16"	G 1/4	32.0	11.0	19	0.032
1700-06-06	10	3/8"	G 3/8	35.5	12.0	22	0.051
1700-08-08	12	1/2"	G 1/2	41.5	14.0	27	0.089
1700-10-10	16	5/8"	G 5/8	46.0	16.0	30	0.115
1700-12-12	20	3/4"	G 3/4	47.0	16.0	32	0.136
1700-16-16	25	1"	G 1	53.0	19.0	41	0.230
1700-20-20	32	1.1/4"	G 1 1/4	57.0	20.0	50	0.365
1700-24-24	38	1.1/2"	G 1 1/2	62.0	22.0	55	0.456
1700-32-32	50	2"	G 2	71.0	25.0	70	0.783

Riduzione diritto maschio BSP (ISO 8434-6)

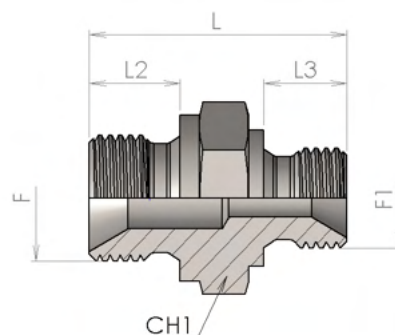
S

Part number	Dimensions								Weight kg/unit
	Ø		F	F1	L	L2	L3	CH1	
	tube mm	tube inch							
1800-04-02	8-6	5/16"-1/4"	G 1/4	G 1/8	28.5	11.0	8	19	0.028
1800-06-02	10-6	3/8"-1/4"	G 3/8	G 1/8	31.0	12.0	8	22	0.041
1800-06-04	10-8	3/8"-5/16"	G 3/8	G 1/4	34.0	12.0	11	22	0.045
1800-08-04	12-8	1/2"-5/16"	G 1/2	G 1/4	37.5	14.0	11	27	0.072
1800-08-06	12-10	1/2"-3/8"	G 1/2	G 3/8	39.5	14.0	12	27	0.080
1800-10-08	16-12	5/8"-1/2"	G 5/8	G 1/2	41.0	16.0	14	30	0.097
1800-12-04	20-8	3/4"-5/16"	G 3/4	G 1/4	40.0	16.0	11	32	0.105
1800-12-06	20-10	3/4"-3/8"	G 3/4	G 3/8	43.0	16.0	12	32	0.118
1800-12-08	20-12	3/4"-1/2"	G 3/4	G 1/2	45.0	16.0	14	32	0.134
1800-12-10	20-16	3/4"-5/8"	G 3/4	G 5/8	46.0	16.0	16	32	0.126
1800-16-06	25-10	1"-3/8"	G 1	G 3/8	45.5	19.0	12	41	0.174
1800-16-08	25-12	1"-1/2"	G 1	G 1/2	48.0	19.0	14	41	0.185
1800-16-10	25-16	1"-5/8"	G 1	G 5/8	49.0	19.0	16	41	0.192
1800-16-12	25-20	1"-3/4"	G 1	G 3/4	49.0	19.0	16	41	0.190
1800-20-12	32-20	1.1/4"-3/4"	G 1 1/4	G 3/4	54.0	20.0	16	50	0.320
1800-20-16	32-25	1.1/4"-1"	G 1 1/4	G 1	55.0	20.0	19	50	0.323
1800-24-12	38-20	1.1/2"-3/4"	G 1 1/2	G 3/4	54.0	22.0	16	55	0.410
1800-24-16	38-25	1.1/2"-1"	G 1 1/2	G 1	59.0	22.0	19	55	0.414
1800-24-20	38-32	1.1/2"-1.1/4"	G 1 1/2	G 1 1/4	60.0	22.0	20	55	0.600
1800-32-16	50-25	2"-1"	G 2	G 1	64.0	22.0	19	70	0.612
1800-32-20	50-32	2"-1.1/4"	G 2	G 1 1/4	65.5	25.0	20	70	0.720
1800-32-24	50-38	2"-1.1/2"	G 2	G 1 1/2	67.5	25.0	22	70	0.735

Riduzione Maschio-Femmina corta (ISO 8434-6)

S

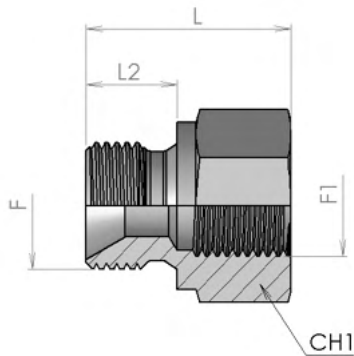

Part number	Dimensions							Weight kg/unit
	Ø		F	F1	L	L2	CH1	
	tube mm	tube inch						
R605-04-02	8-6	5/16"-1/4"	G 1/4	G 1/8	23.0	11.0	19	0.026
R605-06-02	10-6	3/8"-1/4"	G 3/8	G 1/4	21.5	12.0	22	0.036
R605-06-04	10-8	3/8"-5/16"	G 3/8	G 1/4	27.0	12.0	22	0.045
R605-08-04	12-8	1/2"-5/16"	G 1/2	G 1/4	25.0	14.0	27	0.053
R605-08-06	12-10	1/2"-3/8"	G 1/2	G 3/8	28.5	14.0	27	0.058
R605-12-04	20-8	3/4"-5/16"	G 3/4	G 1/4	27.0	16.0	32	0.101
R605-12-06	20-10	3/4"-3/8"	G 3/4	G 3/8	27.0	16.0	32	0.091
R605-12-08	20-12	3/4"-1/2"	G 3/4	G 1/2	33.0	16.0	32	0.072
R605-16-06	25-10	1"-3/8"	G 1	G 3/8	30.0	19.0	41	0.173
R605-16-08	25-12	1"-1/2"	G 1	G 1/2	30.0	19.0	41	0.152
R605-16-12	25-20	1"-3/4"	G 1	G 3/4	30.0	19.0	41	0.131
R605-20-12	32-20	1.1/4"-3/4"	G 1 1/4	G 3/4	34.0	20.0	50	0.271
R605-20-16	32-25	1.1/4"-1"	G 1 1/4	G 1	34.0	20.0	50	0.223
R605-24-12	38-20	1.1/2"-3/4"	G 1 1/2	G 3/4	39.0	22.0	55	0.407
R605-24-16	38-25	1.1/2"-1"	G 1 1/2	G 1	35.0	22.0	55	0.316
R605-24-20	38-32	1.1/2"-1.1/4"	G 1 1/2	G 1 1/4	39.0	22.0	55	0.225
R605-32-20	50-32	2"-1.1/4"	G 2	G 1 1/4	42.5	25.0	70	0.632
R605-32-24	50-38	2"-1.1/2"	G 2	G 1 1/2	42.5	25.0	70	0.521

Colonna Maschio-Femmina (ISO 8434-6)

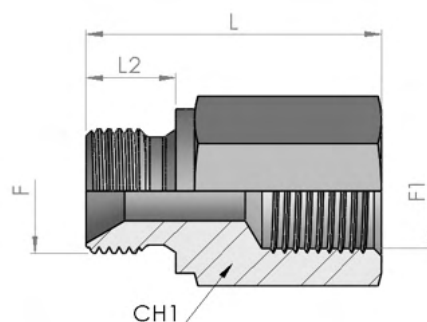
S

Part number	Dimensions							Weight kg/unit
	Ø		F	F1	L	L2	CH1	
	tube mm	tube inch						
2000-02-26	6	1/4"	G 1/8	G 1/8	26.0	8.0	14	0.019
2000-04-33	8	5/16"	G 1/4	G 1/4	33.0	11.0	19	0.041
2000-04-42	8	5/16"	G 1/4	G 1/4	42.0	11.0	19	0.060
2000-04-55	8	5/16"	G 1/4	G 1/4	55.0	11.0	19	0.077
2000-06-35	10	3/8"	G 3/8	G 3/8	35.0	12.0	22	0.052
2000-06-54	10	3/8"	G 3/8	G 3/8	54.0	12.0	22	0.086
2000-06-65	10	3/8"	G 3/8	G 3/8	65.0	12.0	22	0.113
2000-08-35	12	1/2"	G 1/2	G 1/2	35.0	14.0	27	0.073
2000-08-45	12	1/2"	G 1/2	G 1/2	45.0	14.0	27	0.103
2000-08-60	12	1/2"	G 1/2	G 1/2	60.0	14.0	27	0.141
2000-08-80	12	1/2"	G 1/2	G 1/2	80.0	14.0	27	0.197
2000-12-48	20	3/4"	G 3/4	G 3/4	48.0	16.0	32	0.137
2000-12-64	20	3/4"	G 3/4	G 3/4	64.0	16.0	32	0.189
2000-12-75	20	3/4"	G 3/4	G 3/4	75.0	16.0	32	0.250
2000-16-50	25	1"	G 1	G 1	50.0	19.0	41	0.219
2000-16-90	25	1"	G 1	G 1	90.0	19.0	41	0.565
2000-20-62	32	1.1/4"	G 1 1/4	G 1 1/4	62.0	20.0	50	0.408

Riduzione Maschio-Femmina (ISO 8434-6)

S

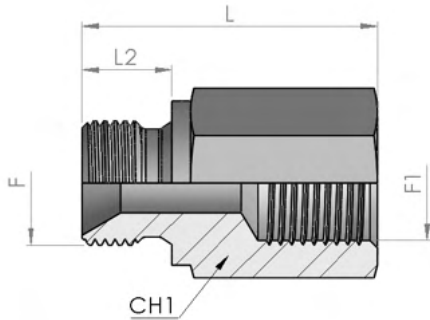

Part number	Dimensions							Weight kg/unit
	Ø		F	F1	L	L2	CH1	
	tube mm	tube inch						
2010-02-04	6-8	1/4"-5/16"	G 1/4	G 1/8	25.0	11.0	19	0.034
2010-04-02	8-6	5/16"-1/4"	G 1/8	G 1/4	29.0	8.0	19	39.000
2010-04-06	8-10	5/16"-3/8"	G 3/8	G 1/4	35.0	12.0	22	0.066
2010-04-08	8-12	5/16"-1/2"	G 1/2	G 1/4	34.0	14.0	27	0.078
2010-06-04	10-8	3/8"-5/16"	G 1/4	G 3/8	36.0	11.0	22	0.050
2010-06-08	10-12	3/8"-1/2"	G 1/2	G 3/8	41.0	14.0	27	0.111
2010-08-04	12-8	1/2"-5/16"	G 1/4	G 1/2	35.0	11.0	27	0.071
2010-08-06	12-10	1/2"-3/8"	G 3/8	G 1/2	38.0	12.0	27	0.083
2010-08-12	12-20	1/2"-3/4"	G 3/4	G 1/2	43.0	16.0	32	0.162
2010-08-16	12-25	1/2"-1"	G 1	G 1/2	42.0	19.0	41	0.260
2010-12-04	20-8	3/4"-5/16"	G 1/4	G 3/4	41.0	11.0	32	0.113
2010-12-06	20-10	3/4"-3/8"	G 3/8	G 3/4	42.5	12.0	32	0.122
2010-12-08	20-12	3/4"-1/2"	G 1/2	G 3/4	53.0	14.0	32	0.148
2010-12-16	20-25	3/4"-1"	G 1	G 3/4	49.0	19.0	41	0.167
2010-16-08	25-12	1"-1/2"	G 1/2	G 1	45.0	14.0	41	0.181
2010-16-12	25-20	1"-3/4"	G 3/4	G 1	47.0	16.0	41	0.214
2010-16-20	25-32	1"-1.1/4"	G 1 1/4	G 1	51.0	20.0	50	0.254
2010-20-12	32-20	1.1/4"-3/4"	G 3/4	G 1 1/4	51.0	16.0	50	0.275
2010-20-16	32-25	1.1/4"-1"	G 1	G 1 1/4	53.0	19.0	50	0.298
2010-20-24	32-38	1.1/4"-1.1/2"	G 1 1/2	G 1 1/4	57.0	22.0	55	0.341
2010-24-16	38-25	1.1/2"-1"	G 1	G 1 1/2	54.0	19.0	55	0.355
2010-24-20	38-32	1.1/2"-1.1/4"	G 1 1/4	G 1 1/2	52.0	20.0	55	0.557
2010-32-20	50-32	2"-1.1/4"	G 1 1/4	G 2	66.0	20.0	70	0.807
2010-32-24	50-38	2"-1.1/2"	G 1 1/2	G 2	68.0	22.0	70	0.852

Prolunga unione diretto maschio BSP (ISO 8434-6)

S

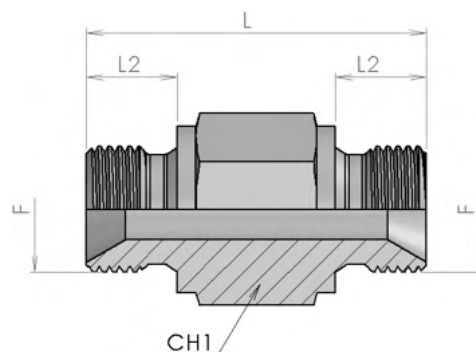

Part number	Dimensions						Weight kg/unit
	Ø		F	L	L2	CH1	
	tube mm	tube inch					
2020-04-04	8	5/16"	G 1/4	45.0	11.0	19	0.062
2020-06-06	10	3/8"	G 3/8	50.0	12.0	22	0.122
2020-08-08	12	1/2"	G 1/2	61.0	14.0	27	0.195
2020-12-12	20	3/4"	G 3/4	73.0	16.0	32	0.248
2020-16-16	25	1"	G 1	84.0	19.0	41	0.480

A108

Passaparete dritto BSP (ISO 8434-6)

BHS

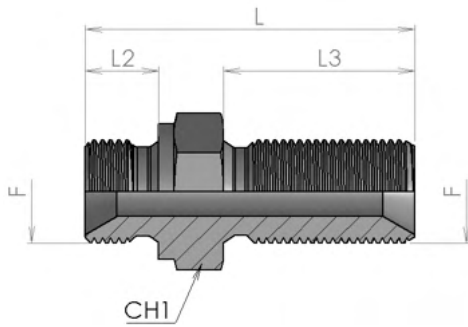

Part number	Dimensions							Weight kg/unit
	Ø		F	L	L1	L2	CH1	
	tube mm	tube inch						
A108-02Z	6	1/4"	G 1/8	34.5	25	8.0	14	0.020
A108-04Z	8	5/16"	G 1/4	46.0	29	11.0	19	0.057
A108-06Z	10	3/8"	G 3/8	53.5	31	12.0	22	0.084
A108-08Z	12	1/2"	G 1/2	60.0	34	14.0	27	0.122
A108-10Z	16	5/8"	G 5/8	65.0	37	16.0	30	0.146
A108-12Z	20	3/4"	G 3/4	66.0	37	16.0	32	0.209
A108-16Z	25	1"	G 1	73.0	41	19.0	41	0.328
A108-20Z	32	1.1/4"	G 1 1/4	79.0	45	20.0	50	0.507

Controdado per passaparete

LN

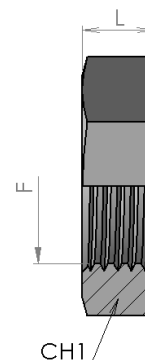

Part number	Dimensions					Weight kg/unit
	Ø		F	L	CH1	
	tube mm	tube inch				
A107-02	6	1/4"	G 1/8	5.0	14	0.004
A107-04	8	5/16"	G 1/4	6.0	19	0.009
A107-06	10	3/8"	G 3/8	7.0	22	0.013
A107-08	12	1/2"	G 1/2	8.0	27	0.021
A107-10	16	5/8"	G 5/8	9.0	30	0.027
A107-12	20	3/4"	G 3/4	9.0	32	0.029
A107-16	25	1"	G 1	10.0	41	0.055
A107-20	32	1.1/4"	G 1 1/4	13.0	50	0.089

Unione a 90° maschio BSP (ISO 8434-6)

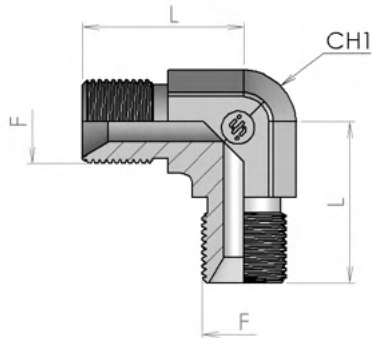

E

Part number	Dimensions					Weight kg/unit
	Ø		F	L1	CH1	
	tube mm	tube inch				
4520-02	6	1/4"	G 1/8	22	12	0.021
4520-04	8	5/16"	G 1/4	27	14	0.045
4520-06	10	3/8"	G 3/8	32	19	0.085
4520-08	12	1/2"	G 1/2	36	22	0.123
4520-12	20	3/4"	G 3/4	42	27	0.178
4520-16	25	1"	G 1	46	33	0.288
4520-20	32	1.1/4"	G 1 1/4	52	41	0.512
4520-24	38	1.1/2"	G 1 1/2	59	50	0.824

Unione a 45° maschio BSP (ISO 8434-6)

E45

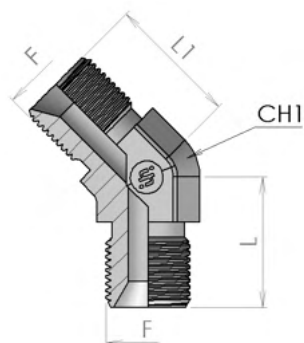

Part number	Dimensions						Weight kg/unit
	Ø		F	L	L1	CH1	
	tube mm	tube inch					
4530-04	8	5/16"	G 1/4	21.5	21.5	14	0.045
4530-06	10	3/8"	G 3/8	26.0	26	19	0.085
4530-08	12	1/2"	G 1/2	30.0	29	22	0.123
4530-12	20	3/4"	G 3/4	35.0	33	27	0.178
4530-16	25	1"	G 1	38.5	37.5	33	0.288

Unione a T maschio BSP (ISO 8434-6)

T

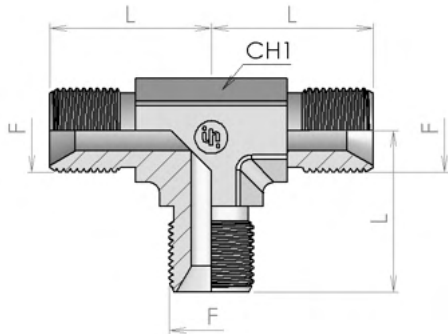

Part number	Dimensions					Weight kg/unit
	Ø		F	L1	CH1	
	tube mm	tube inch				
4730-02	6	1/4"	G 1/8	22	12	0.033
4730-04	8	5/16"	G 1/4	27	14	0.061
4730-06	10	3/8"	G 3/8	32	19	0.105
4730-08	12	1/2"	G 1/2	36	22	0.157
4730-12	20	3/4"	G 3/4	42	27	0.258
4730-16	25	1"	G 1	46	33	0.591
4730-20	32	1.1/4"	G 1 1/4	52	41	0.646
4730-24	38	1.1/2"	G 1 1/2	59	50	0.940

Unione a croce maschio BSP (ISO 8434-6)

K

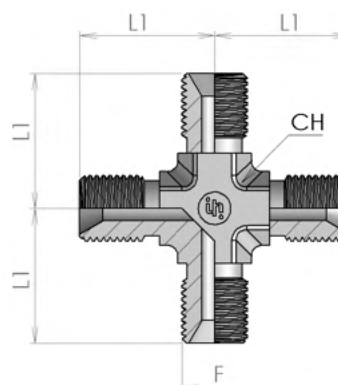

Part number	Dimensions					Weight kg/unit
	Ø		F	L1	CH1	
	tube mm	tube inch				
4900-04	8	5/16"	G 1/4	27	14	0.081
4900-06	10	3/8"	G 3/8	32	19	0.130
4900-08	12	1/2"	G 1/2	36	22	0.181
4900-12	20	3/4"	G 3/4	42	27	0.312

Unione a croce femmina BSP

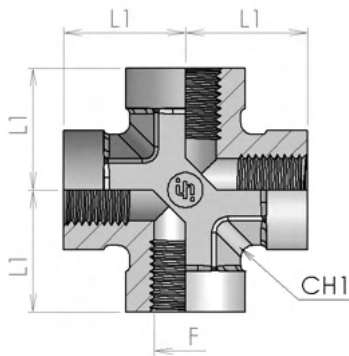

K

Part number	Dimensions					Weight kg/unit
	Ø		F	L1	CH1	
	tube mm	tube inch				
4910-02	6	1/4"	G 1/8	17	14	0.045
4910-04	8	5/16"	G 1/4	22.5	19	0.113
4910-06	10	3/8"	G 3/8	26	22	0.154
4910-08	12	1/2"	G 1/2	31	27	0.257

Girevole a T laterale F/M BSP (8434-6)

SWRT

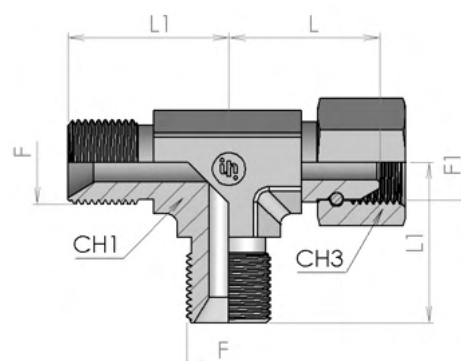

Part number	Dimensions								Weight kg/unit
	Ø		F	F1	L	L1	CH1	CH3	
	tube mm	tube inch							
4700-02	6	1/4"	G 1/8	G 1/8	20.0	22	12	14	0.057
4700-04	8	5/16"	G 1/4	G 1/4	25.0	27	14	19	0.084
4700-06	10	3/8"	G 3/8	G 3/8	30.0	32	19	22	0.152
4700-08	12	1/2"	G 1/2	G 1/2	34.0	36	22	27	0.231
4700-12	20	3/4"	G 3/4	G 3/4	40.0	42	27	32	0.305
4700-16	25	1"	G 1	G 1	43.0	46	33	41	0.474
4700-20	32	1.1/4"	G 1 1/4	G 1 1/4	49.0	52	41	50	0.935
4700-24	38	1.1/2"	G 1 1/2	G 1 1/2	60.0	59	50	55	1.427

Girevole a T centrale F/M BSP (8434-6)

SWBT

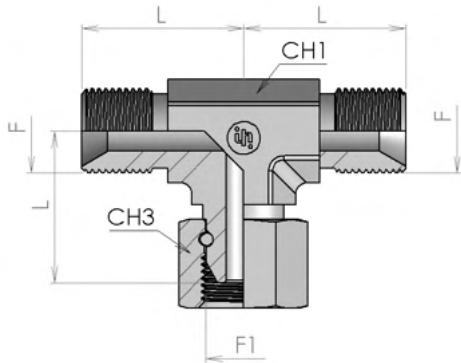

Part number	Dimensions								Weight kg/unit
	Ø		F	F1	L	L1	CH1	CH3	
	tube mm	tube inch							
4710-02	6	1/4"	G 1/8	G 1/8	20.0	22	12	14	0.057
4710-04	8	5/16"	G 1/4	G 1/4	25.0	27	14	19	0.084
4710-06	10	3/8"	G 3/8	G 3/8	30.0	32	19	22	0.152
4710-08	12	1/2"	G 1/2	G 1/2	34.0	36	22	27	0.231
4710-12	20	3/4"	G 3/4	G 3/4	40.0	42	27	32	0.305
4710-16	25	1"	G 1	G 1	43.0	46	33	41	0.474
4710-20	32	1.1/4"	G 1 1/4	G 1 1/4	49.0	52	41	50	0.935
4710-24	38	1.1/2"	G 1 1/2	G 1 1/2	60.0	59	50	55	1.427

Girevole a T con maschio laterale F/M BSP (8434-6)

SWRT

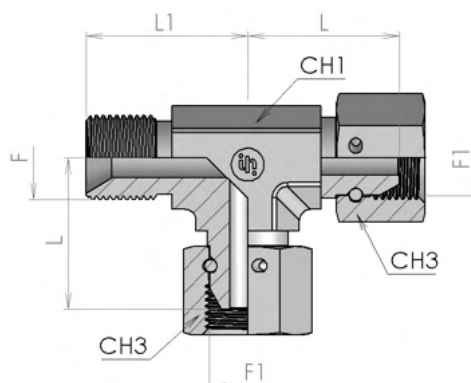

Part number	Dimensions								Weight kg/unit
	Ø		F	F1	L	L1	CH1	CH3	
	tube mm	tube inch							
4800-04	8	5/16"	G 1/4	G 1/4	25.0	27	14	19	0.106
4800-06	10	3/8"	G 3/8	G 3/8	30.0	32	19	22	0.182
4800-08	12	1/2"	G 1/2	G 1/2	34.0	36	22	27	0.281
4800-12	20	3/4"	G 3/4	G 3/4	40.0	42	27	32	0.376
4800-16	25	1"	G 1	G 1	43.0	46	33	41	0.565

Girevole a T con maschio centrale F/M BSP (8434-6)

SWBT

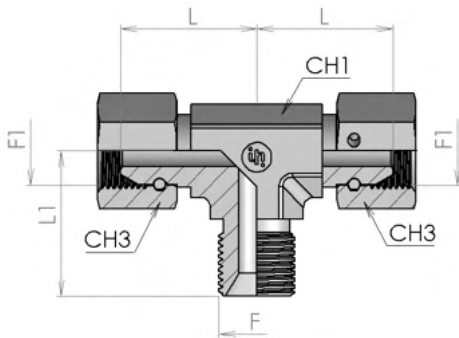

Part number	Dimensions								Weight kg/unit
	Ø		F	F1	L	L1	CH1	CH3	
	tube mm	tube inch							
4810-04	8	5/16"	G 1/4	G 1/4	25.0	27	14	19	0.106
4810-06	10	3/8"	G 3/8	G 3/8	30.0	32	19	22	0.182
4810-08	12	1/2"	G 1/2	G 1/2	34.0	36	22	27	0.281
4810-12	20	3/4"	G 3/4	G 3/4	40.0	42	27	32	0.376
4810-16	25	1"	G 1	G 1	43.0	46	33	41	0.565

Unione a T girevole BSP (ISO 8434-6)

T

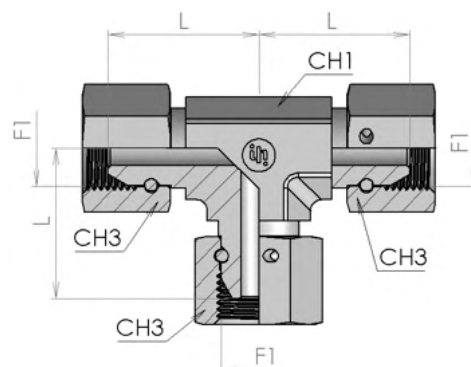

Part number	Dimensions						Weight kg/unit
	Ø		F1	L1	CH1	CH3	
	tube mm	tube inch					
4720-02	6	1/4"	G 1/8	22	12	14	0.058
4720-04	8	5/16"	G 1/4	27	14	19	0.125
4720-06	10	3/8"	G 3/8	32	19	22	0.296
4720-08	12	1/2"	G 1/2	36	22	27	0.324
4720-12	20	3/4"	G 3/4	42	27	32	0.483
4720-16	25	1"	G 1	46	33	41	0.699
4720-20	32	1.1/4"	G 1 1/4	52	41	50	1.294
4720-24	38	1.1/2"	G 1 1/2	59	50	55	1.832

Terminale dritto di riduzione F/M BSP (ISO 8434-6)

RDSW

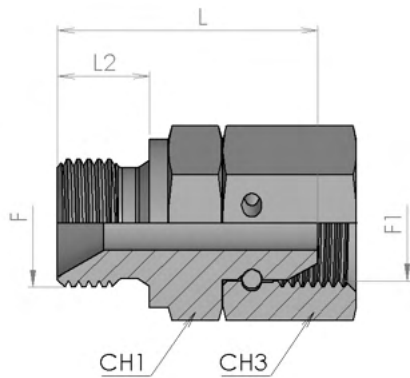

Part number	Dimensions								Weight kg/unit
	Ø		F	F1	L	L2	CH1	CH3	
	tube mm	tube inch							
2350-02-02	6	1/4"	G 1/8	G 1/8	23.0	8.0	14	14	0.030
2350-04-04	8	5/16"	G 1/4	G 1/4	29.0	11.0	19	19	0.049
2350-04-06	8-10	5/16"-3/8"	G 1/4	G 3/8	31.5	11.0	19	22	0.064
2350-06-04	10-8	3/8"-5/16"	G 3/8	G 1/4	31.5	12.0	22	19	0.061
2350-06-06	10	3/8"	G 3/8	G 3/8	34.0	12.0	22	22	0.076
2350-06-08	10-12	3/8"-1/2"	G 3/8	G 1/2	36.0	12.0	22	27	0.105
2350-06-12	10-20	3/8"-3/4"	G 3/8	G 3/4	39.0	12.0	27	32	0.145
2350-08-06	12-10	1/2"-3/8"	G 1/2	G 3/8	37.5	14.0	27	22	0.099
2350-08-08	12	1/2"	G 1/2	G 1/2	39.5	14.0	27	27	0.128
2350-08-10	12-16	1/2"-5/8"	G 1/2	G 5/8	37.0	14.0	27	30	0.160
2350-08-12	12-20	1/2"-3/4"	G 1/2	G 3/4	40.0	14.0	27	32	0.152
2350-10-10	16	5/8"	G 5/8	G 5/8	39.0	16.0	30	30	0.164
2350-12-08	20-12	3/4"-1/2"	G 3/4	G 1/2	39.0	16.0	32	27	0.161
2350-12-12	20	3/4"	G 3/4	G 3/4	43.5	16.0	32	32	0.188
2350-12-16	20-25	3/4"-1"	G 3/4	G 1	44.0	16.0	32	38	0.214
2350-16-12	25-20	1"-3/4"	G 1	G 3/4	47.5	19.0	41	32	0.258
2350-16-16	25	1"	G 1	G 1	48.0	19.0	41	41	0.279
2350-16-20	25-32	1"-1.1/4"	G 1	G 1 1/4	50.5	19.0	41	50	0.426
2350-20-20	32	1.1/4"	G 1 1/4	G 1 1/4	54.5	20.0	50	50	0.536
2350-24-20	38-32	1.1/2"-1.1/4"	G 1 1/2	G 1 1/4	55.5	22.0	55	50	0.587
2350-24-24	38	1.1/2"	G 1 1/2	G 1 1/2	57.5	22.0	55	55	0.619
2350-32-32	50	2"	G 2	G 2	62.5	25.0	70	70	0.781

Girevole a 90° F/M BSP (ISO 8434-6)

SWE

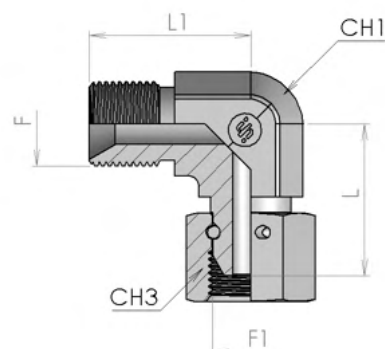

Part number	Dimensions								Weight kg/unit
	Ø		F	F1	L	L1	CH1	CH3	
	tube mm	tube inch							
4500-02	6	1/4"	G 1/8	G 1/8	20.0	22	12	14	0.026
4500-04	8	5/16"	G 1/4	G 1/4	25.0	27	14	19	0.062
4500-06	10	3/8"	G 3/8	G 3/8	30.0	32	19	22	0.104
4500-08	12	1/2"	G 1/2	G 1/2	36.0	34	22	27	0.159
4500-10	16	5/8"	G 5/8	G 5/8	36.0	36	22	30	0.158
4500-12	20	3/4"	G 3/4	G 3/4	40.0	42	27	32	0.226
4500-16	25	1"	G 1	G 1	43.0	46	33	41	0.377
4500-20	32	1.1/4"	G 1 1/4	G 1 1/4	49.0	52	41	50	0.650
4500-24	38	1.1/2"	G 1 1/2	G 1 1/2	60.0	59	50	55	0.999

Girevole a 45° F/M BSP (ISO 8434-6)

SWE45

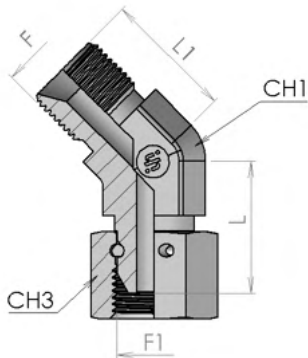

Part number	Dimensions								Weight kg/unit
	Ø		F	F1	L	L1	CH1	CH3	
	tube mm	tube inch							
4510-02	6	1/4"	G 1/8	G 1/8	19.0	20	12	14	0.026
4510-04	8	5/16"	G 1/4	G 1/4	23.5	21.5	14	19	0.062
4510-06	10	3/8"	G 3/8	G 3/8	26.0	26	19	22	0.104
4510-08	12	1/2"	G 1/2	G 1/2	32.0	29	22	27	0.159
4510-12	20	3/4"	G 3/4	G 3/4	33.0	32	27	32	0.226
4510-16	25	1"	G 1	G 1	37.0	37.5	33	41	0.377
4510-20	32	1.1/4"	G 1.1/4	G 1.1/4	37.0	39	41	50	411.000
4510-24	38	1.1/2"	G 1.1/2	G 1.1/2	47.0	46	50	55	649.000

Girevole a 90° F/M BSP versione compatta (ISO 8434-6)

SWE

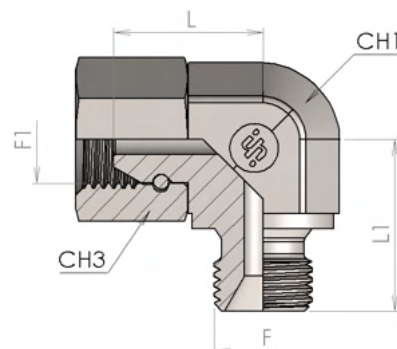

Part number	Dimensions								Weight kg/unit
	Ø		F	F1	L	L1	CH1	CH3	
	tube mm	tube inch							
3220-02-02	6	1/4"	G 1/8	G 1/8	17.0	17	14	14	0.026
3220-04-04	8	5/16"	G 1/4	G 1/4	20.0	23	19	19	0.061
3220-06-06	10	3/8"	G 3/8	G 3/8	24.0	25	22	22	0.089
3220-08-08	12	1/2"	G 1/2	G 1/2	28.0	31	27	27	0.157
3220-12-12	20	3/4"	G 3/4	G 3/4	34.0	35	33	32	0.293
3220-16-16	25	1"	G 1	G 1	39.0	43	41	41	0.473
3220-20-20	32	1.1/4"	G 1 1/4	G 1 1/4	47.0	50	50	50	0.855
3200-24-24	38	1.1/2"	G 1 1/2	G 1 1/2	57.0	56	60	55	1.170
3200-32-32	50	2"	G 2	G 2	60.0	67	75	70	2.011

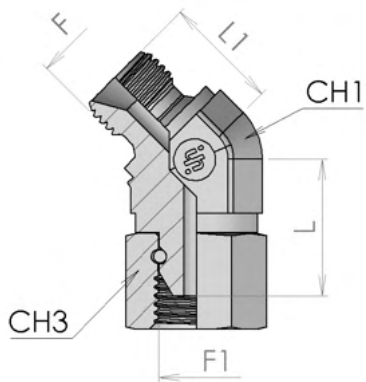

**Girevole a 45° F/M BSP
versione compatta
(ISO 8434-6)**

SWE45

Part number	Dimensions								Weight kg/unit
	Ø		F	F1	L	L1	CH1	CH3	
	tube mm	tube inch							
3320-04-04	8	5/16"	G 1/4	G 1/4	22.5	18	19	19	0.054
3320-06-06	10	3/8"	G 3/8	G 3/8	25.0	21.5	22	22	0.082
3320-08-08	12	1/2"	G 1/2	G 1/2	32.0	22.5	27	27	0.141
3320-12-12	20	3/4"	G 3/4	G 3/4	35.5	31.5	32	32	0.248
3320-16-16	25	1"	G 1	G 1	42.0	33	41	38	0.443

Curva 90° mas/femm. Girevole (saldata)

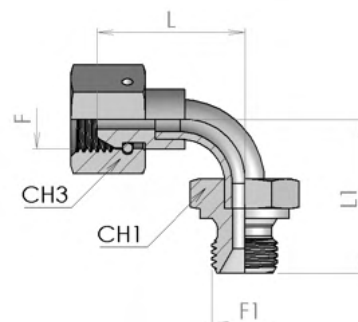

Part number	Dimensions								Weight kg/unit
	Ø		F	F1	L	L1	CH1	CH3	
	tube mm	tube inch							
2550-04-04	8	5/16"	G 1/4	G 1/4	30.0	32	19	19	0.062
2550-06-06	10	3/8"	G 3/8	G 3/8	37.0	38	22	22	0.102
2550-08-08	12	1/2"	G 1/2	G 1/2	44.0	43	27	27	0.108
2550-12-12	20	3/4"	G 3/4	G 3/4	59.0	62	32	32	0.243
2550-16-16	25	1"	G 1	G 1	66.0	68	41	41	0.422
2550-20-20	32	1.1/4"	G 1 1/4	G 1 1/4	71.0	76	50	50	0.575
2550-24-24	38	1.1/2"	G 1 1/2	G 1 1/2	89.0	93	55	55	0.707
2550-32-32	50	2"	G 2	G 2	113.0	123	70	70	1.626

Curva 45° mas/femm. Girevole (saldata)

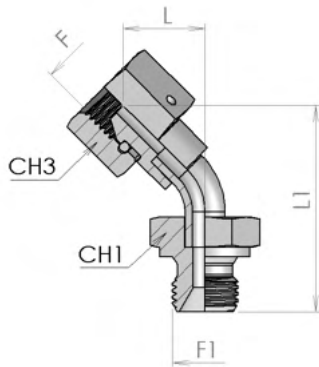

Part number	Dimensions								Weight kg/unit
	Ø		F	F1	L	L1	CH1	CH3	
	tube mm	tube inch							
2650-04-04	8	5/16"	G 1/4	G 1/4	17.0	44	19	19	0.062
2650-06-06	10	3/8"	G 3/8	G 3/8	20.0	52	22	22	0.102
2650-08-08	12	1/2"	G 1/2	G 1/2	23.0	53	27	27	0.108
2650-12-12	20	3/4"	G 3/4	G 3/4	29.0	73	32	32	0.243
2650-16-16	25	1"	G 1	G 1	35.0	85	41	41	0.422
2650-20-20	32	1.1/4"	G 1 1/4	G 1 1/4	33.0	84	50	50	0.575
2650-24-24	38	1.1/2"	G 1 1/2	G 1 1/2	41.0	103	55	55	0.707
2650-32-32	50	2"	G 2	G 2	53.0	134	65	70	1.626

Unione diritto girevole BSP (ISO 8434-6)

S

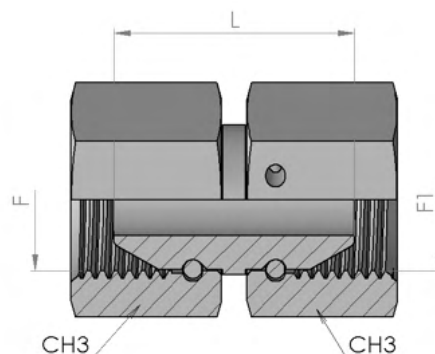

Part number	Dimensions						Weight kg/unit
	Ø		F	F1	L	CH3	
	tube mm	tube inch					
2450-02-02	6	1/4"	G 1/8	G 1/8	10.0	14	0.023
2450-04-04	8	5/16"	G 1/4	G 1/4	22.0	19	0.061
2450-06-06	10	3/8"	G 3/8	G 3/8	29.0	22	0.084
2450-08-08	12	1/2"	G 1/2	G 1/2	32.0	27	0.137
2450-10-10	16	5/8"	G 5/8	G 5/8	29.0	30	0.177
2450-12-12	20	3/4"	G 3/4	G 3/4	37.5	32	0.206
2450-16-16	25	1"	G 1	G 1	42.0	41	0.295
2450-20-20	32	1.1/4"	G 1 1/4	G 1 1/4	50.0	50	0.618
2450-24-24	38	1.1/2"	G 1 1/2	G 1 1/2	53.0	55	0.714
2450-32-32	50	2"	G 2	G 2	50.0	70	1.135

Unione girevole a 90° BSP (ISO 8434-6)

E

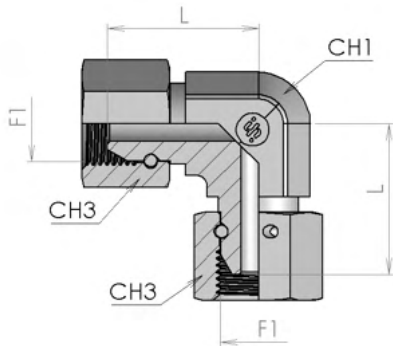

Part number	Dimensions						Weight kg/unit
	Ø		F	L1	CH1	CH3	
	tube mm	tube inch					
4550-04	8	5/16"	G 1/4	25	14	19	0.044
4550-06	10	3/8"	G 3/8	30	19	22	0.088
4550-08	12	1/2"	G 1/2	34	22	27	0.134
4550-12	20	3/4"	G 3/4	40	27	32	0.219
4550-16	25	1"	G 1	43	32	41	0.339
4550-20	32	1.1/4"	G 1 1/4	49	41	50	0.576
4550-24	38	1.1/2"	G 1 1/2	60	50	55	0.978

Curva 90° femmina girevole (saldata)

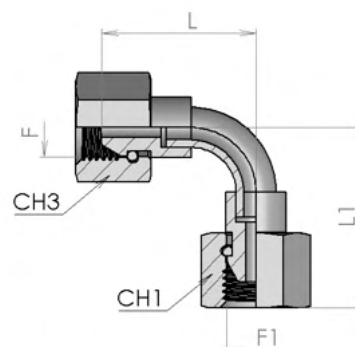

Part number	Dimensions								Weight kg/unit
	Ø		F	F1	L	L1	CH1	CH3	
	tube mm	tube inch							
2750-04-04	8	5/16"	G 1/4	G 1/4	30.0	35	19	19	0.070
2750-06-06	10	3/8"	G 3/8	G 3/8	37.0	43	22	22	0.107
2750-08-08	12	1/2"	G 1/2	G 1/2	44.0	49	27	27	0.111
2750-12-12	20	3/4"	G 3/4	G 3/4	59.0	67	32	32	0.252
2750-16-16	25	1"	G 1	G 1	66.0	76	38	41	0.431
2750-20-20	32	1.1/4"	G 1 1/4	G 1 1/4	71.0	70	50	50	0.586
2750-24-24	38	1.1/2"	G 1 1/2	G 1 1/2	89.0	98	55	55	0.718
2750-32-32	50	2"	G 2	G 2	113.0	127	70	70	1.711

Curva 45° femmina girevole (saldata)

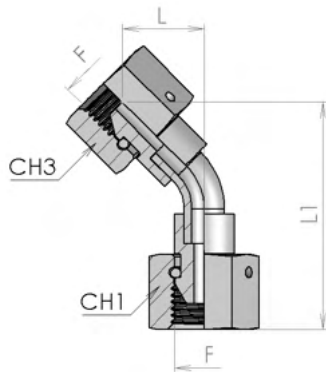

Part number	Dimensions								Weight kg/unit
	Ø		F	F1	L	L1	CH1	CH3	
	tube mm	tube inch							
2850-04-04	8	5/16"	G 1/4	G 1/4	17.0	47	19	19	0.070
2850-06-06	10	3/8"	G 3/8	G 3/8	20.0	57	22	22	0.107
2850-08-08	12	1/2"	G 1/2	G 1/2	23.0	59	27	27	0.111
2850-12-12	20	3/4"	G 3/4	G 3/4	29.0	79	32	32	0.252
2850-16-16	25	1"	G 1	G 1	35.0	93	38	41	0.431
2850-20-20	32	1.1/4"	G 1 1/4	G 1 1/4	33.0	87	50	50	0.586
2850-24-24	38	1.1/2"	G 1 1/2	G 1 1/2	41.0	108	55	55	0.718
2850-32-32	50	2"	G 2	G 2	53.0	139	70	70	1.711

Unione 90° femmina BSP

E

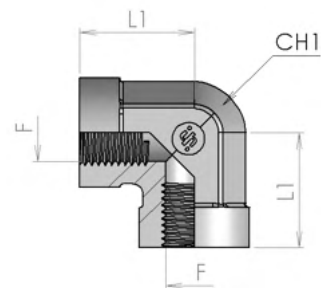

Part number	Dimensions					Weight kg/unit
	Ø		F	L1	CH1	
	tube mm	tube inch				
4570-02	6	1/4"	G 1/8	17	14	0.060
4570-04	8	5/16"	G 1/4	22.5	19	0.081
4570-06	10	3/8"	G 3/8	26	22	0.010
4570-08	12	1/2"	G 1/2	31	27	0.184
4570-12	20	3/4"	G 3/4	34.5	33	0.263
4570-16	25	1"	G 1	41	41	0.502
4570-20	32	1.1/4"	G 1 1/4	43	50	0.663

Unione a T femmina BSP

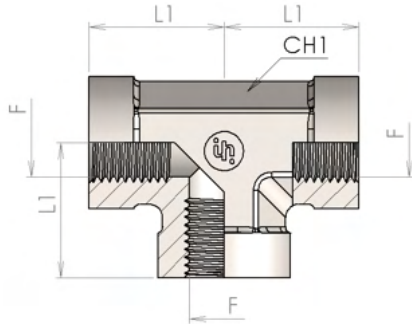

T

Part number	Dimensions					Weight kg/unit
	Ø		F	L1	CH1	
	tube mm	tube inch				
4820-02	6	1/4"	G 1/8	17	14	0.040
4820-04	8	5/16"	G 1/4	22.5	19	0.074
4820-06	10	3/8"	G 3/8	26	22	0.111
4820-08	12	1/2"	G 1/2	31	27	0.177
4820-12	20	3/4"	G 3/4	34.5	33	0.294
4820-16	25	1"	G 1	41	41	0.567
4820-20	32	1.1/4"	G 1 1/4	43	50	0.084

Unione femmina fissa BSP (ISO 8434-6)

S

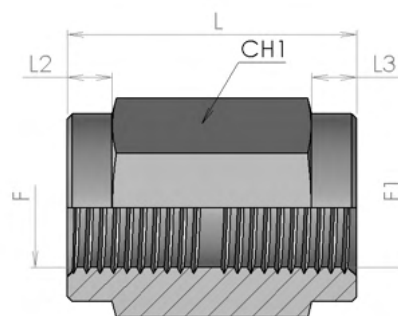

Part number	Dimensions								Weight kg/unit
	\emptyset		F	F1	L	L2	L3	CH1	
	tube mm	tube inch							
A105-02-02	6	1/4"	G 1/8	G 1/8	21.0	4.5	4.5	14	0.015
A105-02-04	6-8	1/4"-5/16"	G 1/8	G 1/4	29.0	4.5	4.5	19	0.029
A105-04-04	8	5/16"	G 1/4	G 1/4	29.0	4.5	4.5	19	0.034
A105-04-06	8-10	5/16"-3/8"	G 1/4	G 3/8	31.0	4.5	4.5	22	0.059
A105-06-06	10	3/8"	G 3/8	G 3/8	29.0	4.5	4.5	22	0.048
A105-06-08	10-12	3/8"-1/2"	G 3/8	G 1/2	32.0	4.5	4.5	27	0.082
A105-08-08	12	1/2"	G 1/2	G 1/2	34.0	4.5	4.5	27	0.081
A105-08-12	12-20	1/2"-3/4"	G 1/2	G 3/4	38.0	4.5	4.5	32	0.126
A105-12-12	20	3/4"	G 3/4	G 3/4	38.0	4.5	4.5	32	0.108
A105-12-16	20-25	3/4"-1"	G 3/4	G 1	43.0	4.5	4.5	41	0.152
A105-16-16	25	1"	G 1	G 1	43.0	4.5	4.5	41	0.211
A105-20-20	32	1.1/4"	G 1 1/4	G 1 1/4	47.0	4.5	4.5	50	0.312
A105-24-24	38	1.1/2"	G 1 1/2	G 1 1/2	51.0	4.5	4.5	55	0.357
A105-32-32	50	2"	G 2	G 2	57.0	4.5	4.5	70	0.591

Tappo Femmina Girevole BSP (ISO 8434-6)

BRNP

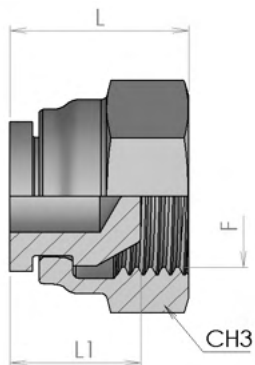

Part number	Dimensions						Weight kg/unit
	Ø		F	L	L1	CH3	
	tube mm	tube inch					
A608-02	6	1/4"	G 1/8	14.0	10.5	14	0.003
A608-04	8	5/16"	G 1/4	16.0	12	19	0.008
A608-06	10	3/8"	G 3/8	20.0	15	22	0.014
A608-08	12	1/2"	G 1/2	24.0	17	27	0.024
A608-10	16	5/8"	G 5/8	24.0	15	30	0.270
A608-12	20	3/4"	G 3/4	27.0	19	32	0.044
A608-16	25	1"	G 1	31.0	21	41	0.076
A608-20	32	1.1/4"	G 1 1/4	31.0	23.5	50	0.144
A608-24	38	1.1/2"	G 1 1/2	31.0	25.5	55	0.195
A608-32	50	2"	G 2	36.0	23	70	0.286

Tappo BSP

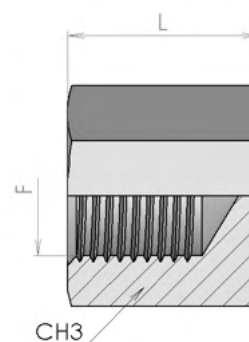

Part number	Dimensions					Weight kg/unit
	Ø		F	L	CH3	
	tube mm	tube inch				
A604-02	6	1/4"	G 1/8	15.5	14	0.017
A604-04	8	5/16"	G 1/4	19.0	19	0.032
A604-06	10	3/8"	G 3/8	17.0	22	0.050
A604-08	12	1/2"	G 1/2	23.0	27	0.070
A604-10	16	5/8"	G 5/8	19.0	30	0.093
A604-12	20	3/4"	G 3/4	22.0	32	0.109
A604-16	25	1"	G 1	31.0	41	0.202
A604-20	32	1.1/4"	G 1 1/4	36.0	50	0.371
A604-24	38	1.1/2"	G 1 1/2	41.0	55	0.494
A604-32	50	2"	G 2	45.5	70	0.881

A605

Tappo Maschio BSP (ISO 8434-6)

PL

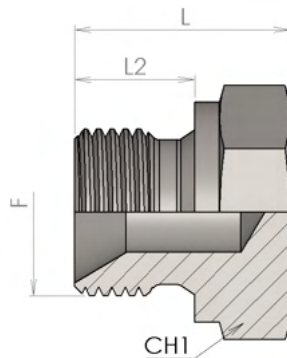

Part number	Dimensions						Weight kg/unit
	Ø		F	L	L2	CH1	
	tube mm	tube inch					
A605-02	6	1/4"	G 1/8	14.5	8.0	14	0.011
A605-04	8	5/16"	G 1/4	19.0	11.0	19	0.024
A605-06	10	3/8"	G 3/8	21.5	12.0	22	0.039
A605-08	12	1/2"	G 1/2	25.0	14.0	27	0.067
A605-10	16	5/8"	G 5/8	27.0	16.0	30	0.088
A605-12	20	3/4"	G 3/4	27.0	16.0	32	0.098
A605-16	25	1"	G 1	31.0	19.0	41	0.168
A605-20	32	1.1/4"	G 1 1/4	34.0	20.0	50	0.317
A605-24	38	1.1/2"	G 1 1/2	39.0	22.0	55	0.434
A605-32	50	2"	G 2	42.5	25.0	70	0.760

Terminale dritto maschio BSP a saldare con tasca

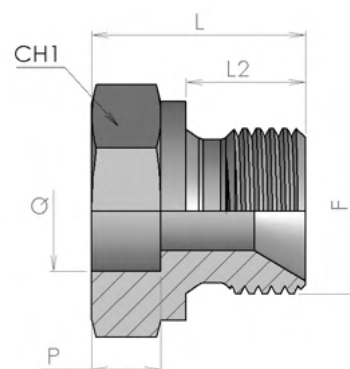
BRS

Part number	Dimensions								Weight kg/unit
	Ø		F	L	L2	Q	P	CH1	
	tube mm	tube inch							
MG-04-08	8	5/16"	G 1/4	19.0	11.0	8	6	19	0.023
MG-06-12	10	3/8"	G 3/8	21.5	12.0	12	7	22	0.034
MG-08-14	12	1/2"	G 1/2	25.0	14.0	14	8	27	0.057
MG-08-16	12	1/2"	G 1/2	25.0	14.0	16	8	27	0.055
MG-08-18	12	1/2"	G 1/2	25.0	14.0	18	8	27	0.053
MG-08-20	12	1/2"	G 1/2	24.0	14.0	20	5	27	0.051
MG-12-20	20	3/4"	G 3/4	27.0	16.0	20	9	32	0.083
MG-12-22	20	3/4"	G 3/4	27.0	16.0	22	8	32	0.080
MG-12-25	20	3/4"	G 3/4	27.0	16.0	25	9	32	0.070
MG-16-25	25	1"	G 1	30.0	19.0	25	9	41	0.147
MG-16-30	25	1"	G 1	30.0	19.0	30	9	41	0.132
MG-20-32	32	1.1/4"	G 1 1/4	34.0	20.0	32	9	50	0.250
MG-24-38	38	1.1/2"	G 1 1/2	35.0	22.0	38	10	55	0.281

220C

Mezzo nipplo tondo a saldare BSP

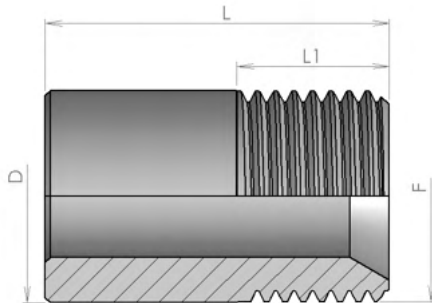

Part number	Dimensions						Weight kg/unit
	Ø		F	D	L	L1	
	tube mm	tube inch					
220C-02	6	1/4"	G 1/8	10	22.0	9	0.010
220C-04	8	5/16"	G 1/4	14	30.0	12	0.024
220C-06	10	3/8"	G 3/8	17	32.0	14	0.036
220C-08	12	1/2"	G 1/2	21	34.0	15	0.056
220C-12	20	3/4"	G 3/4	28	40.0	16	0.120
220C-16	25	1"	G 1	34	41.0	19	0.167
220C-20	32	1.1/4"	G 1 1/4	48	50.0	23	0.355

Borchia a saldare

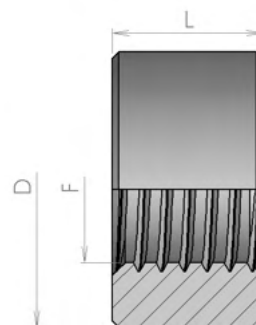

Part number	Dimensions					Weight kg/unit
	Ø		F	D	L	
	tube mm	tube inch				
2200-02	6	1/4"	G 1/8	20	13.0	0.025
2200-04	8	5/16"	G 1/4	22	16.0	0.033
2200-06	10	3/8"	G 3/8	26	17.0	0.045
2200-08	12	1/2"	G 1/2	30	18.0	0.056
2200-12	20	3/4"	G 3/4	38	20.0	0.098
2200-16	25	1"	G 1	45	25.0	0.155
2200-20	32	1.1/4"	G 1 1/4	55	25.0	0.212
2200-24	38	1.1/2"	G 1 1/2	62	30.0	0.310
2200-32	50	2"	G 2	70	30.0	0.272

Terminale diritto M/M BSP-BSPT

SDS

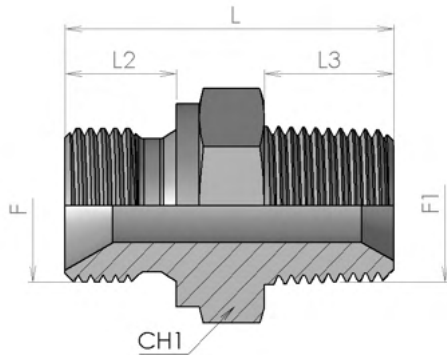

Part number	Dimensions								Weight kg/unit
	Ø		F	F1	L	L2	L3	CH1	
	tube mm	tube inch							
1865-02-02	6	1/4"	G 1/8	R 1/8 K	23.5	8.0	9	14	0.014
1865-04-04	8	5/16"	G 1/4	R 1/4 K	33.0	11.0	14	19	0.034
1865-06-06	10	3/8"	G 3/8	R 3/8 K	35.5	12.0	14	22	0.049
1865-08-08	12	1/2"	G 1/2	R 1/2 K	41.0	14.0	18	27	0.082
1865-08-12	12-20	1/2"-3/4"	G 1/2	R 3/4 K	45.5	14.0	19	27	0.109
1865-12-08	20-12	3/4"-1/2"	G 3/4	R 1/2 K	45.0	16.0	18	32	0.121
1865-12-12	20	3/4"	G 3/4	R 3/4 K	46.0	16.0	19	32	0.136
1865-16-16	25	1"	G 1	R 1 K	54.0	19.0	24	41	0.224
1865-20-20	32	1.1/4"	G 1 1/4	R 1 1/4 K	59.0	20.0	24.5	50	0.361
1865-24-24	38	1.1/2"	G 1 1/2	R 1 1/2 K	60.5	22.0	25.5	55	0.448
1865-32-32	50	2"	G 2	R 2 K	72.5	25.0	30	70	0.816

Terminale dritto di riduzione F BSP/M BSPT

SWS

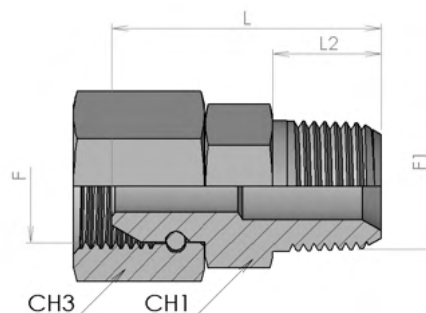

Part number	Dimensions								Weight kg/unit
	Ø		F	F1	L	L2	CH1	CH3	
	tube mm	tube inch							
2360-02-02	6	1/4"	G 1/8	R 1/8 K	29.0	10.0	12	14	0.030
2360-04-04	8	5/16"	G 1/4	R 1/4 K	33.0	14.5	14	19	0.049
2360-06-06	10	3/8"	G 3/8	R 3/8 K	36.0	14.5	19	22	0.076
2360-06-08	10-12	3/8"-1/2"	G 3/8	R 1/2 K	40.0	19.0	22	22	0.105
2360-08-06	12-10	1/2"-3/8"	G 1/2	R 3/8 K	42.0	14.5	22	27	0.099
2360-08-08	12	1/2"	G 1/2	R 1/2 K	45.0	19.0	22	27	0.128
2360-12-08	20-12	3/4"-1/2"	G 3/4	R 1/2 K	47.0	19.0	27	32	0.161
2360-12-12	20	3/4"	G 3/4	R 3/4 K	47.0	19.5	27	32	0.188
2360-12-16	20-25	3/4"-1"	G 3/4	R 1 K	55.0	24.0	36	41	0.214
2360-16-16	25	1"	G 1	R 1 K	60.0	24.0	36	41	0.279
2360-20-20	32	1.1/4"	G 1 1/4	R 1 1/4 K	62.0	24.5	46	50	0.536
2360-24-24	38	1.1/2"	G 1 1/2	R 1 1/2 K	67.0	25.5	50	55	0.619

Terminale a T M BSP/ M BSPT centrale

SDEBT

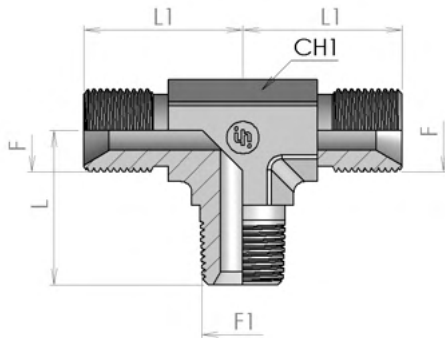

Part number	Dimensions							Weight kg/unit
	Ø		F	F1	L	L1	CH1	
	tube mm	tube inch						
4860-02	6	1/4"	G 1/8	R 1/8 K	19.5	22	12	0.031
4860-04	8	5/16"	G 1/4	R 1/4 K	27.5	27	14	0.066
4860-06	10	3/8"	G 3/8	R 3/8 K	31.0	32	19	0.124
4860-08	12	1/2"	G 1/2	R 1/2 K	36.0	36	22	0.187
4860-12	20	3/4"	G 3/4	R 3/4 K	40.5	42	27	0.300
4860-16	25	1"	G 1	R 1 K	50.0	46	33	0.442
4860-20	32	1.1/4"	G 1 1/4	R 1 1/4 K	60.5	52	41	0.783

Gomito 90° M BSP/ M BSPT

SDE

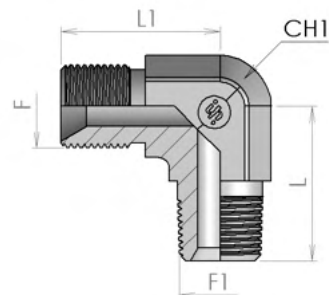

Part number	Dimensions							Weight kg/unit
	Ø		F	F1	L	L1	CH1	
	tube mm	tube inch						
4620-02	6	1/4"	G 1/8	R 1/8 K	19.5	22	12	0.015
4620-04	8	5/16"	G 1/4	R 1/4 K	27.5	27	14	0.042
4620-06	10	3/8"	G 3/8	R 3/8 K	31.0	32	19	0.093
4620-08	12	1/2"	G 1/2	R 1/2 K	36.0	36	22	0.142
4620-12	20	3/4"	G 3/4	R 3/4 K	40.5	42	27	0.231
4620-16	25	1"	G 1	R 1 K	50.0	46	33	0.372
4620-20	32	1.1/4"	G 1 1/4	R 1 1/4 K	60.5	52	41	0.593
4620-24	38	1.1/2"	G 1 1/2	R 1 1/2 K	67.0	59	50	0.835

Gomito 45° M BSP/ M BSPT

SDE45

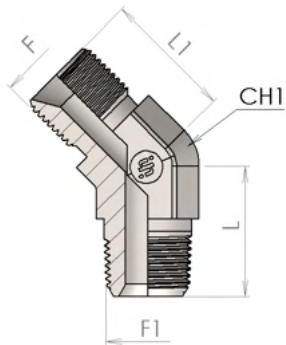

Part number	Dimensions							Weight kg/unit
	Ø		F	F1	L	L1	CH1	
	tube mm	tube inch						
4630-02	6	1/4"	G 1/8	R 1/8 K	18.5	20	12	0.015
4630-04	8	5/16"	G 1/4	R 1/4 K	23.0	21.5	14	0.042
4630-06	10	3/8"	G 3/8	R 3/8 K	26.0	26	19	0.093
4630-08	12	1/2"	G 1/2	R 1/2 K	31.0	29	22	0.142
4630-12	20	3/4"	G 3/4	R 3/4 K	33.5	33	27	0.231
4630-16	25	1"	G 1	R 1 K	39.0	37.5	33	0.372

Girevole a 90° F BSP-M BSPT

SWE

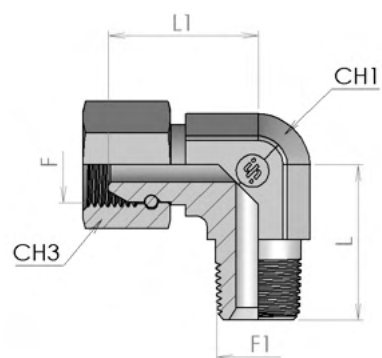

Part number	Dimensions								Weight kg/unit
	Ø		F	F1	L	L1	CH1	CH3	
	tube mm	tube inch							
4600-02	6	1/4"	G 1/8	R 1/8 K	19.5	20	12	14	0.017
4600-04	8	5/16"	G 1/4	R 1/4 K	27.5	25	14	19	0.046
4600-06	10	3/8"	G 3/8	R 3/8 K	31.0	30	19	22	0.090
4600-08	12	1/2"	G 1/2	R 1/2 K	36.0	34	22	27	0.139
4600-12	20	3/4"	G 3/4	R 3/4 K	40.5	40	27	32	0.232
4600-16	25	1"	G 1	R 1 K	50.0	43	33	41	0.261
4600-20	32	1.1/4"	G 1 1/4	R 1 1/4 K	60.5	49	41	50	0.484
4600-24	38	1.1/2"	G 1 1/2	R 1 1/2 K	67.0	60	50	55	0.831

4610

**Girevole a 45° F BSP-M
BSPT**

SWE45

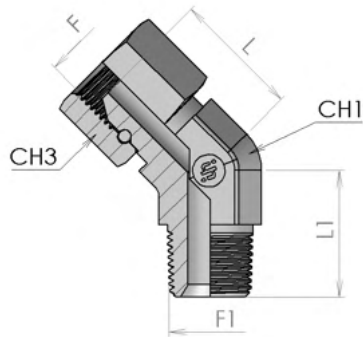

Part number	Dimensions								Weight kg/unit
	Ø		F	F1	L	L1	CH1	CH3	
	tube mm	tube inch							
4610-04	8	5/16"	G 1/4	R 1/4 K	21.0	26	14	19	0.045
4610-06	10	3/8"	G 3/8	R 3/8 K	25.5	25.5	19	22	0.072
4610-08	12	1/2"	G 1/2	R 1/2 K	25.0	29	22	27	0.099
4610-12	20	3/4"	G 3/4	R 3/4 K	33.0	31	27	32	0.172
4610-16	25	1"	G 1	R 1 K	45.0	33.5	33	38	0.304

Terminale diritto M/M BSP-NPTF

SDS

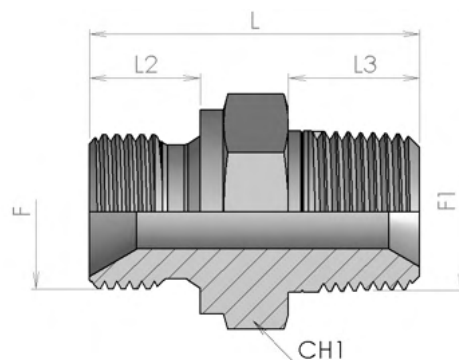

Part number	Dimensions								Weight kg/unit
	Ø		F	F1	L	L2	L3	CH1	
	tube mm	tube inch							
1875-02-02	6	1/4"	G 1/8	1/8 NPTF	24.5	8.0	10	14	0.015
1875-04-04	8	5/16"	G 1/4	1/4 NPTF	33.0	11.0	14.5	19	0.032
1875-04-06	8-10	5/16"-3/8"	G 1/4	3/8 NPTF	34.0	11.0	14.5	19	0.040
1875-06-04	10-8	3/8"-5/16"	G 3/8	1/4 NPTF	35.5	12.0	14.5	22	0.047
1875-06-06	10	3/8"	G 3/8	3/8 NPTF	35.5	12.0	14.5	22	0.051
1875-06-08	10-12	3/8"-1/2"	G 3/8	1/2 NPTF	40.5	12.0	19	22	0.061
1875-08-06	12-10	1/2"-3/8"	G 1/2	3/8 NPTF	39.5	14.0	14.5	27	0.068
1875-08-08	12	1/2"	G 1/2	1/2 NPTF	44.0	14.0	19	27	0.083
1875-08-12	12-20	1/2"-3/4"	G 1/2	3/4 NPTF	45.5	14.0	19	27	0.101
1875-12-08	20-12	3/4"-1/2"	G 3/4	1/2 NPTF	45.5	16.0	19	32	0.116
1875-12-12	20	3/4"	G 3/4	3/4 NPTF	46.0	16.0	19.5	32	0.119
1875-12-16	20-25	3/4"-1"	G 3/4	1 NPTF	53.0	16.0	24	36	0.203
1875-16-12	25-20	1"-3/4"	G 1	3/4 NPTF	49.0	19.0	19	41	0.199
1875-16-16	25	1"	G 1	1 NPTF	54.0	19.0	24	41	0.222
1875-16-20	25-32	1"-1.1/4"	G 1	1 1/4 NPTF	57.0	19.0	24.5	46	0.264
1875-20-20	32	1.1/4"	G 1 1/4	1 1/4 NPTF	58.5	20.0	24.5	50	0.306
1875-24-24	38	1.1/2"	G 1 1/2	1 1/2 NPTF	60.5	22.0	25.5	55	0.431
1875-32-32	50	2"	G 2	2 NPTF	68.5	25.0	26	70	0.755

Terminale dritto di riduzione F BSP/M NPTF

SWS

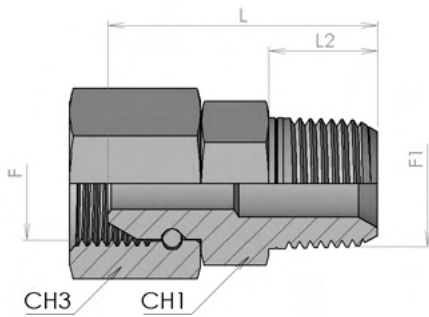

Part number	Dimensions								Weight kg/unit
	Ø		F	F1	L	L2	CH1	CH3	
	tube mm	tube inch							
2365-02-02	6	1/4"	G 1/8	1/8 NPTF	27.0	10.0	12	14	0.030
2365-04-04	8	5/16"	G 1/4	1/4 NPTF	33.0	14.0	14	19	0.049
2365-04-06	8-10	5/16"-3/8"	G 1/4	3/8 NPTF	36.0	14.5	17	22	0.064
2365-06-04	10-8	3/8"-5/16"	G 3/8	1/4 NPTF	34.0	14.0	19	19	0.061
2365-06-06	10	3/8"	G 3/8	3/8 NPTF	36.0	14.5	19	22	0.076
2365-06-08	10-12	3/8"-1/2"	G 3/8	1/2 NPTF	40.0	19.0	22	27	0.105
2365-08-06	12-10	1/2"-3/8"	G 1/2	3/8 NPTF	39.0	14.5	22	22	0.099
2365-08-08	12	1/2"	G 1/2	1/2 NPTF	43.5	19.0	22	27	0.128
2365-08-12	12-20	1/2"-3/4"	G 1/2	3/4 NPTF	46.0	19.5	27	32	0.152
2365-12-08	20-12	3/4"-1/2"	G 3/4	1/2 NPTF	47.0	19.0	27	27	0.161
2365-12-12	20	3/4"	G 3/4	3/4 NPTF	46.0	19.5	27	32	0.188
2365-12-16	20-25	3/4"-1"	G 3/4	1 NPTF	55.0	24.0	36	41	0.214
2365-16-12	25-20	1"-3/4"	G 1	3/4 NPTF	54.0	19.0	36	41	0.258
2365-16-16	25	1"	G 1	1 NPTF	60.0	24.0	36	41	0.279
2365-20-20	32	1.1/4"	G 1 1/4	1 1/4 NPTF	62.0	24.5	46	50	0.536
2365-24-24	38	1.1/2"	G 1 1/2	1 1/2 NPTF	67.0	25.5	50	55	0.619

Terminale a T M BSP/ M NPTF centrale

SDEBT

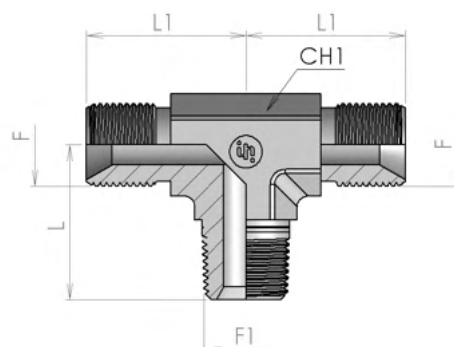

Part number	Dimensions							Weight kg/unit
	Ø		F	F1	L	L1	CH1	
	tube mm	tube inch						
4870-02	6	1/4"	G 1 1/4	1 1/2 NPTF	19.5	22	12	0.031
4870-04	8	5/16"	G 1 1/2	1 1/2 NPTF	27.5	27	14	0.066
4870-06	10	3/8"	G 2	2 NPTF	31.0	32	19	0.124
4870-08	12	1/2"	G 1/2	1/2 NPTF	36.0	36	22	0.187
4870-12	20	3/4"	G 3/4	3/4 NPTF	40.5	42	27	0.300
4870-16	25	1"	G 1	1 NPTF	50.0	46	33	0.442

Gomito 90° M BSP/ M NPTF

SDE

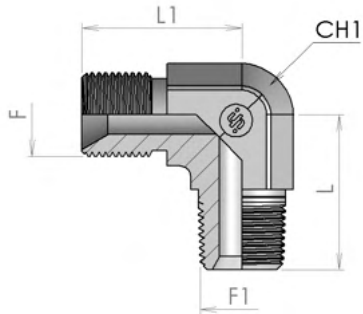

Part number	Dimensions							Weight kg/unit
	Ø		F	F1	L	L1	CH1	
	tube mm	tube inch						
4670-02	6	1/4"	G 1/8	1/8 NPTF	19.5	22	12	0.015
4670-04	8	5/16"	G 1/4	1/4 NPTF	27.5	27	14	0.042
4670-06	10	3/8"	G 3/8	3/8 NPTF	31.0	32	19	0.093
4670-08	12	1/2"	G 1/2	1/2 NPTF	36.0	36	22	0.142
4670-12	20	3/4"	G 3/4	3/4 NPTF	40.5	42	27	0.231
4670-16	25	1"	G 1	1 NPTF	50.0	46	33	0.372
4670-20	32	1.1/4"	G 1 1/4	1 1/4 NPTF	60.5	52	41	0.593

Gomito 45° M BSP/M NPTF

SDE45

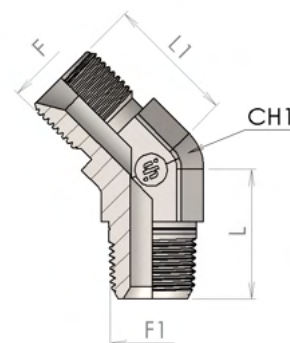

Part number	Dimensions							Weight kg/unit
	Ø		F	F1	L	L1	CH1	
	tube mm	tube inch						
4680-02	6	1/4"	G 1/8	1/8 NPTF	18.5	20	12	0.015
4680-04	8	5/16"	G 1/4	1/4 NPTF	23.0	21.5	14	0.042
4680-06	10	3/8"	G 3/8	3/8 NPTF	26.0	26	19	0.093
4680-08	12	1/2"	G 1/2	1/2 NPTF	31.0	29	22	0.142
4680-12	20	3/4"	G 3/4	3/4 NPTF	33.5	33	27	0.231
4680-16	25	1"	G 1	1 NPTF	39.0	37.5	33	0.372

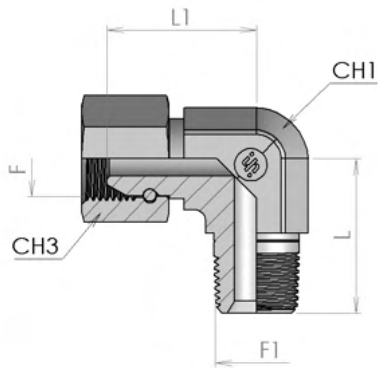

**Girevole a 90° F BSP-M
NPTF**

SWE

Part number	Dimensions								Weight kg/unit
	Ø		F	F1	L	L1	CH1	CH3	
	tube mm	tube inch							
4650-02	6	1/4"	G 1/8	1/8 NPTF	19.5	20	12	14	0.017
4650-04	8	5/16"	G 1/4	1/4 NPTF	27.5	25	14	19	0.046
4650-06	10	3/8"	G 3/8	3/8 NPTF	31.0	30	19	22	0.090
4650-08	12	1/2"	G 1/2	1/2 NPTF	36.0	34	22	27	0.139
4650-12	20	3/4"	G 3/4	3/4 NPTF	40.5	40	27	32	0.232
4650-16	25	1"	G 1	1 NPTF	50.0	43	33	41	0.261
4650-20	32	1.1/4"	G 1 1/4	1 1/4 NPTF	60.5	49	41	50	0.484
4650-24	38	1.1/2"	G 1 1/2	1 1/2 NPTF	67.0	60	50	55	0.831

Terminale dritto M/M BSP-BSPP (Form E ISO 1179-2)

SDS

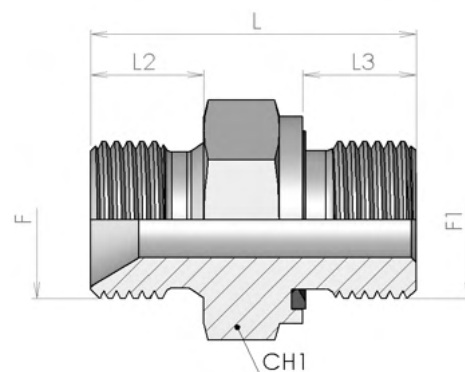

Part number	Dimensions								Weight kg/unit
	Ø		F	F1	L	L2	L3	CH1	
	tube mm	tube inch							
1700E04-04	8	5/16"	G 1/4	G 1/4	32.0	11.0	12	19	0.035
1700E06-06	10	3/8"	G 3/8	G 3/8	34.5	12.0	12	22	0.053
1700E08-08	12	1/2"	G 1/2	G 1/2	41.0	14.0	14	27	0.083
1700E12-12	20	3/4"	G 3/4	G 3/4	47.0	16.0	16	32	0.141
1700E16-16	25	1"	G 1	G 1	54.0	19.0	18	41	0.243

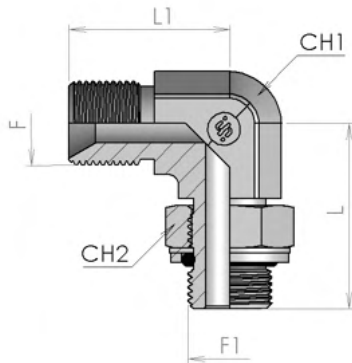

Curva Orientabile 90° M/M BSP BSP (ISO 1179)

SDE

Part number	Dimensions								Weight kg/unit
	Ø		F	F1	L	L1	CH1	CH2	
	tube mm	tube inch							
3900-02-02	6	1/4"	G 1/8	G 1/8	27.0	22	12	14	0.028
3900-04-02	8-6	5/16"-1/4"	G 1/8	G 1/4	33.0	24.5	14	19	0.045
3900-04-04	8	5/16"	G 1/4	G 1/4	33.0	27	14	19	0.050
3900-04-06	8-10	5/16"-3/8"	G 3/8	G 1/4	35.0	32	19	19	0.084
3900-06-02	10-6	3/8"-1/4"	G 1/8	G 3/8	37.0	27	19	22	0.087
3900-06-04	10-8	3/8"-5/16"	G 1/4	G 3/8	37.0	29.5	19	22	0.091
3900-06-06	10	3/8"	G 3/8	G 3/8	37.0	32	19	22	0.094
3900-06-08	10-12	3/8"-1/2"	G 1/2	G 3/8	40.0	36	22	22	0.140
3900-08-04	12-8	1/2"-5/16"	G 1/4	G 1/2	43.0	31.5	22	27	0.135
3900-08-06	12-10	1/2"-3/8"	G 3/8	G 1/2	43.0	34	22	27	0.142
3900-08-08	12	1/2"	G 1/2	G 1/2	43.0	36	22	27	0.147
3900-08-12	12-20	1/2"-3/4"	G 3/4	G 1/2	46.5	42	27	27	0.224
3900-12-06	20-10	3/4"-3/8"	G 3/8	G 3/4	50.0	37	27	36	0.231
3900-12-08	20-12	3/4"-1/2"	G 1/2	G 3/4	50.0	39	27	36	0.239
3900-12-12	20	3/4"	G 3/4	G 3/4	50.0	42	27	36	0.248
3900-12-16	20-25	3/4"-1"	G 1	G 3/4	50.0	44	33	36	0.310
3900-16-12	25-20	1"-3/4"	G 3/4	G 1	53.0	44	33	41	0.370
3900-16-16	25	1"	G 1	G 1	53.0	46	33	41	0.374
3900-16-20	25-32	1"-1.1/4"	G 1 1/4	G 1	55.5	52	41	41	0.469
3900-20-16	32-25	1.1/4"-1"	G 1	G 1 1/4	58.0	49	41	50	564.000
3900-20-20	32	1.1/4"	G 1 1/4	G 1 1/4	58.0	52	41	50	0.658
3900-24-24	38	1.1/2"	G 1 1/2	G 1 1/2	63.0	59	50	55	0.970

Curva Orientabile 90° M/F BSP Girevole BSP (ISO 1179)

SWSDE

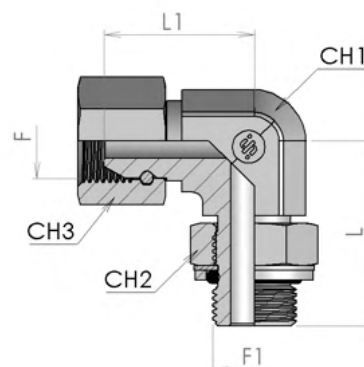

Part number	Dimensions									Weight kg/unit
	Ø		F	F1	L	L1	CH1	CH2	CH3	
	tube mm	tube inch								
3255-02-02	6	1/4"	G 1/8	G 1/8	27.0	20	12	14	14	0.021
3255-04-04	8	5/16"	G 1/4	G 1/4	33.0	25	14	19	19	0.049
3255-06-06	10	3/8"	G 3/8	G 3/8	37.0	30	19	22	22	0.091
3255-08-08	12	1/2"	G 1/2	G 1/2	43.0	34	22	27	27	0.143
3255-12-12	20	3/4"	G 3/4	G 3/4	50.0	40	27	36	32	0.245
3255-16-16	25	1"	G 1	G 1	53.0	43	33	41	41	0.368
3255-20-20	32	1.1/4"	G 1 1/4	G 1 1/4	58.0	49	41	50	50	0.621
3255-24-24	38	1.1/2"	G 1 1/2	G 1 1/2	63.0	60	50	55	55	0.955

Curva Orientabile 45° M/M BSP BSP (ISO 1179)

SDE45

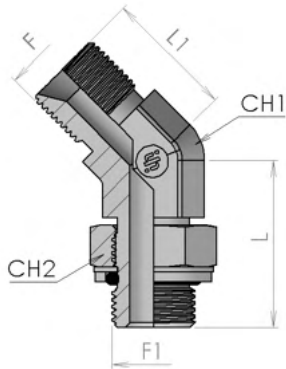

Part number	Dimensions								Weight kg/unit
	Ø		F	F1	L	L1	CH1	CH2	
	tube mm	tube inch							
3950-02-02	6	1/4"	G 1/8	G 1/8	27.0	20	12	14	0.028
3950-04-02	8-6	5/16"-1/4"	G 1/8	G 1/4	28.5	21.5	14	19	0.045
3950-04-04	8	5/16"	G 1/4	G 1/4	30.0	21.5	14	19	0.050
3950-06-04	10-8	3/8"-5/16"	G 1/4	G 3/8	31.5	26	19	22	0.091
3950-06-06	10	3/8"	G 3/8	G 3/8	33.5	26	19	22	0.094
3950-08-06	12-10	1/2"-3/8"	G 3/8	G 1/2	36.0	29	22	27	0.142
3950-08-08	12	1/2"	G 1/2	G 1/2	39.0	29	22	27	0.147
3950-12-08	20-12	3/4"-1/2"	G 1/2	G 3/4	41.5	44	27	36	0.239
3950-12-12	20	3/4"	G 3/4	G 3/4	44.0	33	27	36	0.248
3950-16-12	25-20	1"-3/4"	G 3/4	G 1	45.5	37.5	33	41	0.370
3950-16-16	25	1"	G 1	G 1	47.0	37.5	33	41	0.374
3950-20-16	32-25	1.1/4"-1"	G 1	G 1 1/4	49.5	38	41	50	0.564
3950-20-20	32	1.1/4"	G 1 1/4	G 1 1/4	52.0	38	41	50	0.658

Terminale a T Orientabile laterale M/M BSP-BSP (ISO 1179)

SDRT

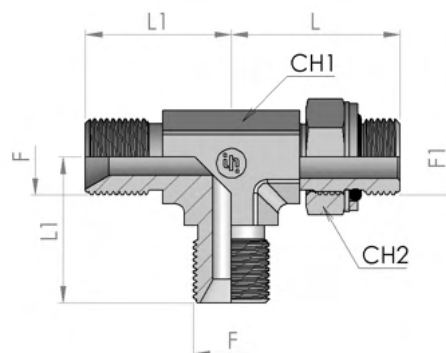

Part number	Dimensions								Weight kg/unit
	Ø		F	F1	L	L1	CH1	CH2	
	tube mm	tube inch							
3600-02-02	6	1/4"	G 1/8	G 1/8	27.0	22	12	14	0.038
3600-04-02	8-6	5/16"-1/4"	G 1/8	G 1/4	33.0	24.5	14	19	0.061
3600-04-04	8	5/16"	G 1/4	G 1/4	33.0	27	14	19	0.068
3600-04-06	8-10	5/16"-3/8"	G 3/8	G 1/4	35.0	32	19	19	0.113
3600-06-04	10-8	3/8"-5/16"	G 1/4	G 3/8	37.0	29.5	19	22	0.123
3600-06-06	10	3/8"	G 3/8	G 3/8	37.0	32	19	22	0.127
3600-06-08	10-12	3/8"-1/2"	G 1/2	G 3/8	40.0	36	22	22	0.189
3600-08-06	12-10	1/2"-3/8"	G 3/8	G 1/2	43.0	34	22	27	0.192
3600-08-08	12	1/2"	G 1/2	G 1/2	43.0	36	22	27	0.199
3600-08-12	12-20	1/2"-3/4"	G 3/4	G 1/2	46.5	42	27	27	0.302
3600-12-08	20-12	3/4"-1/2"	G 1/2	G 3/4	50.0	39	27	36	0.323
3600-12-12	20	3/4"	G 3/4	G 3/4	50.0	42	27	36	0.335
3600-12-16	20-25	3/4"-1"	G 1	G 3/4	50.0	44	33	36	0.419
3600-16-12	25-20	1"-3/4"	G 3/4	G 1	53.0	44	33	41	0.500
3600-16-16	25	1"	G 1	G 1	53.0	46	33	41	0.505
3600-16-20	25-32	1"-1.1/4"	G 1 1/4	G 1	55.5	52	41	41	0.633
3600-20-20	32	1.1/4"	G 1 1/4	G 1 1/4	58.0	52	41	50	0.888
3600-24-24	38	1.1/2"	G 1 1/2	G 1 1/2	63.0	59	50	55	1.310

Terminale a T Orientabile centrale M/M BSP-BSP (ISO 1179)

SDBT

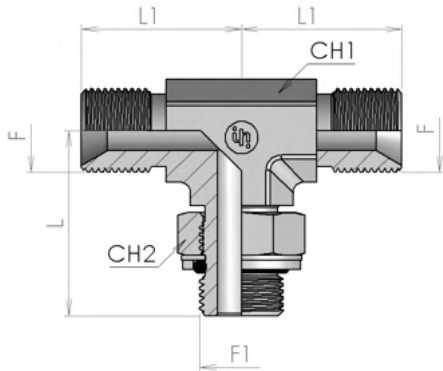

Part number	Dimensions								Weight kg/unit
	Ø		F	F1	L	L1	CH1	CH2	
	tube mm	tube inch							
3605-02-02	6	1/4"	G 1/8	G 1/8	27.0	22	12	14	0.038
3605-04-02	8-6	5/16"-1/4"	G 1/8	G 1/4	33.0	24.5	14	19	0.061
3605-04-04	8	5/16"	G 1/4	G 1/4	33.0	27	14	19	0.068
3605-04-06	8-10	5/16"-3/8"	G 3/8	G 1/4	35.0	32	19	19	0.113
3605-06-04	10-8	3/8"-5/16"	G 1/4	G 3/8	37.0	29.5	19	22	0.123
3605-06-06	10	3/8"	G 3/8	G 3/8	37.0	32	19	22	0.127
3605-06-08	10-12	3/8"-1/2"	G 1/2	G 3/8	40.0	36	22	22	0.189
3605-08-06	12-10	1/2"-3/8"	G 3/8	G 1/2	43.0	34	22	27	0.192
3605-08-08	12	1/2"	G 1/2	G 1/2	43.0	36	22	27	0.199
3605-08-12	12-20	1/2"-3/4"	G 3/4	G 1/2	46.5	42	27	27	0.302
3605-12-08	20-12	3/4"-1/2"	G 1/2	G 3/4	50.0	39	27	36	0.323
3605-12-12	20	3/4"	G 3/4	G 3/4	50.0	42	27	36	0.335
3605-12-16	20-25	3/4"-1"	G 1	G 3/4	50.0	44	33	36	0.419
3605-16-12	25-20	1"-3/4"	G 3/4	G 1	53.0	44	33	41	0.500
3605-16-16	25	1"	G 1	G 1	53.0	46	33	41	0.505
3605-16-20	25-32	1"-1.1/4"	G 1 1/4	G 1	55.5	52	41	41	0.633
3605-20-20	32	1.1/4"	G 1 1/4	G 1 1/4	58.0	52	41	50	0.888
3605-24-24	38	1.1/2"	G 1 1/2	G 1 1/2	63.0	59	50	55	1.310

Unione diritto M/M BSP/Metrico

SDS

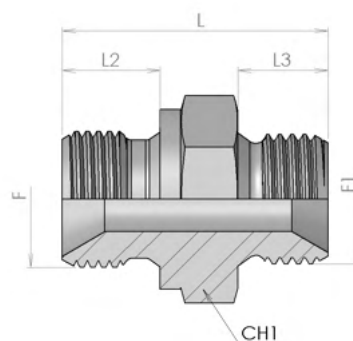

Part number	Dimensions								Weight kg/unit
	Ø		F	F1	L	L2	L3	CH1	
	tube mm	tube inch							
1805-02-10	6	1/4"	G 1/8	M 10x1	22.5	8.0	8	14	0.013
1805-04-10	8	5/16"	G 1/4	M 10x1	27.0	11.0	8	19	0.031
1805-04-12	8	5/16"	G 1/4	M 12x1,5	31.0	11.0	10	19	0.033
1805-04-14	8	5/16"	G 1/4	M 14x1,5	31.0	11.0	10	19	0.030
1805-04-16	8	5/16"	G 1/4	M 16x1,5	31.0	11.0	11	22	0.039
1805-04-18	8	5/16"	G 1/4	M 18x1,5	34.0	11.0	11	24	0.049
1805-04-22	8	5/16"	G 1/4	M 22x1,5	36.0	11.0	12	27	0.061
1805-06-12	10	3/8"	G 3/8	M 12x1,5	33.5	12.0	10	22	0.043
1805-06-14	10	3/8"	G 3/8	M 14x1,5	33.5	12.0	10	22	0.044
1805-06-16	10	3/8"	G 3/8	M 16x1,5	33.5	12.0	11	22	0.046
1805-06-18	10	3/8"	G 3/8	M 18x1,5	34.5	12.0	11	24	0.055
1805-06-20	10	3/8"	G 3/8	M 20x1,5	36.5	12.0	12	27	0.061
1805-06-22	10	3/8"	G 3/8	M 22x1,5	36.5	12.0	12	27	0.068
1805-08-14	12	1/2"	G 1/2	M 14x1,5	37.0	14.0	10	27	0.058
1805-08-16	12	1/2"	G 1/2	M 16x1,5	37.0	14.0	11	27	0.060
1805-08-18	12	1/2"	G 1/2	M 18x1,5	37.0	14.0	11	27	0.066
1805-08-20	12	1/2"	G 1/2	M 20x1,5	39.0	14.0	12	27	0.069
1805-08-22	12	1/2"	G 1/2	M 22x1,5	39.0	14.0	12	27	0.070
1805-12-18	20	3/4"	G 3/4	M 18x1,5	39.0	16.0	11	32	0.111
1805-12-20	20	3/4"	G 3/4	M 20x1,5	41.0	16.0	12	32	0.115
1805-12-22	20	3/4"	G 3/4	M 22x1,5	41.0	16.0	12	32	0.119
1805-12-26	20	3/4"	G 3/4	M 26x1,5	43.0	16.0	12	32	0.124
1805-12-30	20	3/4"	G 3/4	M 30x1,5	44.0	16.0	14	36	0.166
1805-16-22	25	1"	G 1	M 22x1,5	41.0	19.0	12	41	0.165
1805-16-26	25	1"	G 1	M 26x1,5	46.0	19.0	12	41	0.204
1805-16-38	25	1"	G 1	M 38 x1,5	46.0	19.0	14	46	0.243

Terminale dritto M/M BSP/Metrico con O-ring e anellino

SDS

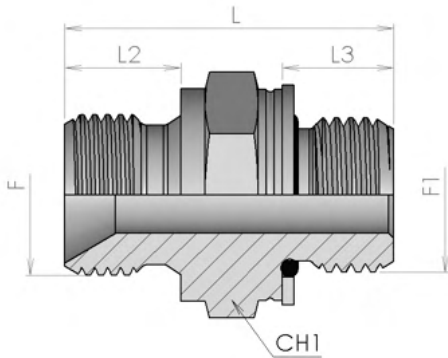

Part number	Dimensions								Weight kg/unit
	Ø		F	F1	L	L2	L3	CH1	
	tube mm	tube inch							
3510-10-02	6	1/4"	G 1/8	M 10x1	24.0	8.0	8.5	14	0.018
3510-12-02	6	1/4"	G 1/8	M 12x1,5	27.0	8.0	11	17	0.026
3510-14-04	8	5/16"	G 1/4	M 14x1,5	31.5	11.0	11	19	0.037
3510-16-04	8	5/16"	G 1/4	M 16x1,5	33.0	11.0	11.5	22	0.044
3510-16-06	10	3/8"	G 3/8	M 16x1,5	34.0	12.0	11.5	22	0.051
3510-18-06	10	3/8"	G 3/8	M 18x1,5	36.0	12.0	12.5	24	0.060
3510-18-08	12	1/2"	G 1/2	M 18x1,5	38.0	14.0	12.5	24	0.078
3510-22-08	12	1/2"	G 1/2	M 22x1,5	39.5	14.0	13	27	0.104
3510-22-12	20	3/4"	G 3/4	M 22x1,5	42.0	16.0	13	30	0.125
3510-27-12	20	3/4"	G 3/4	M 27x2	44.5	16.0	16	36	0.159
3510-27-16	25	1"	G 1	M 27x2	47.5	19.0	16	36	0.204
3510-33-16	25	1"	G 1	M 33x2	52.0	19.0	16	41	0.269
3510-42-20	32	1.1/4"	G 1 1/4	M 42x2	55.0	20.0	16	50	0.427
3510-48-24	38	1.1/2"	G 1 1/2	M 48x2	59.5	22.0	17.5	55	0.534

Curva Orientabile 90° M/M BSP Metrico con o-ring e anello

SWSDE

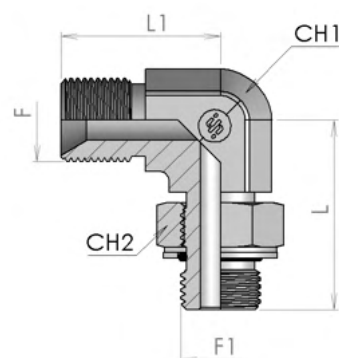

Part number	Dimensions								Weight kg/unit
	Ø		F	F1	L	L1	CH1	CH2	
	tube mm	tube inch							
3910-10-02	6	1/4"	G 1/8	M 10x1	29.0	22	12	14	0.029
3910-12-02	6	1/4"	G 1/8	M 12x1,5	31.0	22	12	17	0.045
3910-14-04	8	5/16"	G 1/4	M 14x1,5	34.0	27	14	19	0.049
3910-16-04	8	5/16"	G 1/4	M 16x1,5	38.0	29.5	14	22	0.055
3910-16-06	10	3/8"	G 3/8	M 16x1,5	38.0	32	19	22	0.094
3910-18-06	10	3/8"	G 3/8	M 18x1,5	41.0	34	19	24	0.135
3910-18-08	12	1/2"	G 1/2	M 18x1,5	41.0	36	22	24	0.141
3910-22-08	12	1/2"	G 1/2	M 22x1,5	43.0	36	22	27	0.147
3910-22-12	20	3/4"	G 3/4	M 22x1,5	47.5	42	27	27	0.185
3910-27-12	20	3/4"	G 3/4	M 27x2	52.0	42	27	32	0.249
3910-27-16	25	1"	G 1	M 27x2	53.0	46	33	32	0.350
3910-33-16	25	1"	G 1	M 33x2	54.0	46	33	41	0.367
3910-42-20	32	1.1/4"	G 1 1/4	M 42x2	60.0	52	41	50	0.645
3910-48-24	38	1.1/2"	G 1 1/2	M 48x2	67.0	59	50	55	1.012

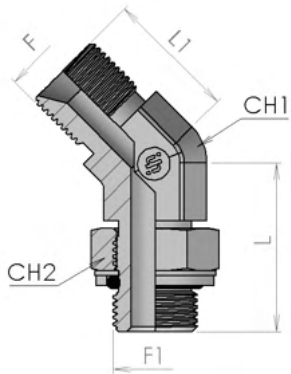

Curva Orientabile 45° M/M BSP Metrico con o-ring e anello

SDE45

Part number	Dimensions								Weight kg/unit
	Ø		F	F1	L	L1	CH1	CH2	
	tube mm	tube inch							
3410-10-02	6	1/4"	G 1/8	M 10x1	27.0	20	12	14	0.029
3410-12-02	6	1/4"	G 1/8	M 12x1,5	28.5	20	12	17	0.045
3410-14-04	8	5/16"	G 1/4	M 14x1,5	32.0	21.5	14	19	0.049
3410-16-04	8	5/16"	G 1/4	M 16x1,5	33.0	21.5	14	22	0.055
3410-16-06	10	3/8"	G 3/8	M 16x1,5	34.0	26	19	22	0.094
3410-18-06	10	3/8"	G 3/8	M 18x1,5	35.0	26	19	24	0.135
3410-18-08	12	1/2"	G 1/2	M 18x1,5	36.0	29	22	24	0.141
3410-22-08	12	1/2"	G 1/2	M 22x1,5	38.0	29	22	27	0.147
3410-22-12	20	3/4"	G 3/4	M 22x1,5	41.5	33	27	27	0.185
3410-27-12	20	3/4"	G 3/4	M 27x2	45.0	33	27	32	0.249
3410-27-16	25	1"	G 1	M 27x2	46.5	37.5	33	32	0.350
3410-33-16	25	1"	G 1	M 33x2	48.0	37.5	33	41	0.367
3410-42-20	32	1.1/4"	G 1 1/4	M 42x2	53.5	38	41	50	0.645
3410-48-24	38	1.1/2"	G 1 1/2	M 48x2	58.0	43	50	55	1.012

Terminale a T Orientabile laterale M/M BSP-Metrico con o-ring e anello

SDRT

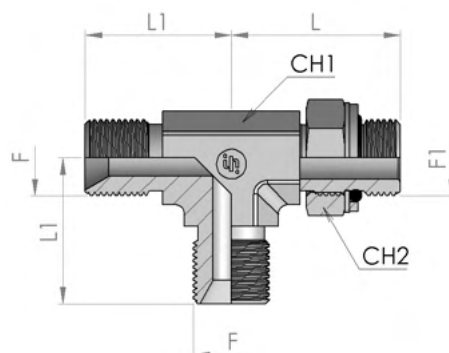

Part number	Dimensions								Weight kg/unit
	Ø		F	F1	L	L1	CH1	CH2	
	tube mm	tube inch							
3610-10-02	6	1/4"	G 1/8	M 10x1	29.0	22	12	14	0.039
3610-12-02	6	1/4"	G 1/8	M 12x1,5	31.0	22	12	17	0.060
3610-14-04	8	5/16"	G 1/4	M 14x1,5	34.0	27	14	19	0.065
3610-16-04	8	5/16"	G 1/4	M 16x1,5	38.0	29.5	14	22	0.073
3610-16-06	10	3/8"	G 3/8	M 16x1,5	38.0	32	19	22	0.125
3610-18-06	10	3/8"	G 3/8	M 18x1,5	41.0	34	19	24	0.180
3610-18-08	12	1/2"	G 1/2	M 18x1,5	41.0	36	22	24	0.188
3610-22-08	12	1/2"	G 1/2	M 22x1,5	43.0	36	22	27	0.196
3610-22-12	20	3/4"	G 3/4	M 22x1,5	47.5	42	27	27	0.247
3610-27-12	20	3/4"	G 3/4	M 27x2	52.0	42	27	32	0.332
3610-27-16	25	1"	G 1	M 27x2	53.0	46	33	32	0.467
3610-33-16	25	1"	G 1	M 33x2	54.0	46	33	41	0.489
3610-42-20	32	1.1/4"	G 1 1/4	M 42x2	60.0	52	41	50	0.860
3610-48-24	38	1.1/2"	G 1 1/2	M 48x2	67.0	59	50	55	1.349

Terminale a T Orientabile centrale M/M BSP-Metrico con o-ring e anello

SDBT

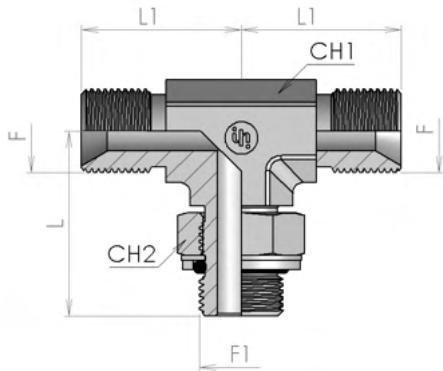

Part number	Dimensions								Weight kg/unit
	Ø		F	F1	L	L1	CH1	CH2	
	tube mm	tube inch							
3615-10-02	6	1/4"	G 1/8	M 10x1	29.0	22	12	14	0.039
3615-12-02	6	1/4"	G 1/8	M 12x1,5	31.0	22	12	17	0.060
3615-14-04	8	5/16"	G 1/4	M 14x1,5	34.0	27	14	19	0.065
3615-16-04	8	5/16"	G 1/4	M 16x1,5	38.0	29.5	14	22	0.073
3615-16-06	10	3/8"	G 3/8	M 16x1,5	38.0	32	19	22	0.125
3615-18-06	10	3/8"	G 3/8	M 18x1,5	41.0	34	19	24	0.180
3615-18-08	12	1/2"	G 1/2	M 18x1,5	41.0	36	22	24	0.188
3615-22-08	12	1/2"	G 1/2	M 22x1,5	43.0	36	22	27	0.196
3615-22-12	20	3/4"	G 3/4	M 22x1,5	47.5	42	27	27	0.247
3615-27-12	20	3/4"	G 3/4	M 27x2	52.0	42	27	32	0.332
3615-27-16	25	1"	G 1	M 27x2	53.0	46	33	32	0.467
3615-33-16	25	1"	G 1	M 33x2	54.0	46	33	41	0.489
3615-42-20	32	1.1/4"	G 1 1/4	M 42x2	60.0	52	41	50	0.860
3615-48-24	38	1.1/2"	G 1 1/2	M 48x2	67.0	59	50	55	1.349

Unione diretto M/M BSP/UNF (ISO 11926)

SDS

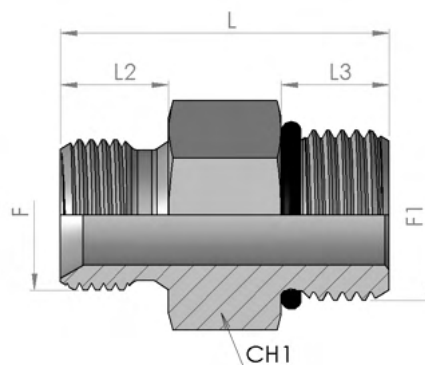

Part number	Dimensions								Weight kg/unit
	Ø		F	F1	L	L2	L3	CH1	
	tube mm	tube inch							
3520-04-02	6	1/4"	G 1/8	7/16-20 UNF	26.0	8.0	9	14	0.021
3520-05-02	8-6	5/16"-1/4"	G 1/8	1/2-20 UNF	26.0	8.0	9	17	0.025
3520-06-04	10-8	3/8"-5/16"	G 1/4	9/16-18 UNF	30.0	11.0	10	17	0.029
3520-08-04	12-8	1/2"-5/16"	G 1/4	3/4-16 UNF	31.5	11.0	11	22	0.051
3520-08-06	12-10	1/2"-3/8"	G 3/8	3/4-16 UNF	33.0	12.0	11	22	0.053
3520-08-08	12	1/2"	G 1/2	3/4-16 UNF	36.5	14.0	11	22	0.063
3520-10-06	16-10	5/8"-3/8"	G 3/8	7/8-14 UNF	35.5	12.0	12.5	27	0.079
3520-10-08	16-12	5/8"-1/2"	G 1/2	7/8-14 UNF	38.0	14.0	12.5	27	0.101
3520-10-12	16-20	5/8"-3/4"	G 3/4	7/8-14 UNF	41.0	16.0	12.5	32	0.122
3520-12-08	20-12	3/4"-1/2"	G 1/2	1 1/16-12 UN	41.5	16.0	15	32	0.131
3520-12-12	20	3/4"	G 3/4	1 1/16-12 UN	43.5	16.0	15	32	0.135
3520-12-16	20-25	3/4"-1"	G 1	1 1/16-12 UN	47.5	19.0	15	36	0.178
3520-16-12	25-20	1"-3/4"	G 3/4	1 5/16-12 UN	44.5	16.0	15	41	0.191
3520-16-16	25	1"	G 1	1 5/16-12 UN	47.5	19.0	15	41	0.204
3520-20-20	32	1.1/4"	G 1 1/4	1 5/8 UN	50.5	20.0	15	50	0.359
3520-24-24	38	1.1/2"	G 1 1/2	1 7/8-12 UN	54.5	22.0	15	55	0.464

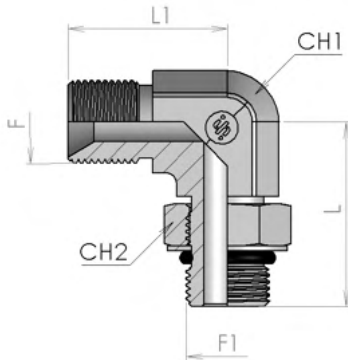

Curva Orientabile 90° M/M BSP UNF (ISO 11926)

SDE

Part number	Dimensions								Weight kg/unit
	Ø		F	F1	L	L1	CH1	CH2	
	tube mm	tube inch							
3920-04-02	6	1/4"	G 1/8	7/16-20 UNF	27.0	22	12	17	0.031
3920-05-02	8-6	5/16"-1/4"	G 1/8	1/2-20 UNF	30.0	25	14	17	0.041
3920-06-04	10-8	3/8"-5/16"	G 1/4	9/16-18 UNF	33.0	27	14	19	0.053
3920-08-04	12-8	1/2"-5/16"	G 1/4	3/4-16 UNF	37.0	29.5	19	24	0.075
3920-08-06	12-10	1/2"-3/8"	G 3/8	3/4-16 UNF	37.0	32	19	24	0.105
3920-08-08	12	1/2"	G 1/2	3/4-16 UNF	37.0	36	22	24	0.118
3920-10-06	16-10	5/8"-3/8"	G 3/8	7/8-14 UNF	43.0	34	22	27	0.135
3920-10-08	16-12	5/8"-1/2"	G 1/2	7/8-14 UNF	43.0	36	22	27	0.159
3920-10-12	16-20	5/8"-3/4"	G 3/4	7/8-14 UNF	43.0	42	27	27	0.178
3920-12-08	20-12	3/4"-1/2"	G 1/2	1 1/16-12 UN	50.0	39	27	36	0.211
3920-12-12	20	3/4"	G 3/4	1 1/16-12 UN	50.0	42	27	36	0.258
3920-16-12	25-20	1"-3/4"	G 3/4	1 5/16-12 UN	53.0	44	33	41	0.298
3920-16-16	25	1"	G 1	1 5/16-12 UN	53.0	46	33	41	0.367
3920-20-20	32	1.1/4"	G 1 1/4	1 5/8 UN	58.0	52	41	50	0.615
3920-24-24	38	1.1/2"	G 1 1/2	1 7/8-12 UN	63.0	59	50	55	0.994

Curva Orientabile 45° M/M BSP UNF (ISO 11926)

SDE45

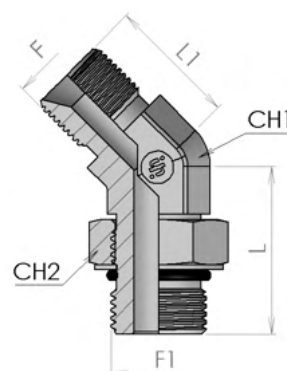

Part number	Dimensions								Weight kg/unit
	Ø		F	F1	L	L1	CH1	CH2	
	tube mm	tube inch							
3420-04-02	6	1/4"	G 1/8	7/16-20 UNF	27.0	20	12	17	0.031
3420-05-02	8-6	5/16"-1/4"	G 1/8	1/2-20 UNF	28.0	21	14	17	0.041
3420-06-04	10-8	3/8"-5/16"	G 1/4	9/16-18 UNF	30.0	21.5	14	19	0.053
3420-08-04	12-8	1/2"-5/16"	G 1/4	3/4-16 UNF	33.5	23.5	19	24	0.075
3420-08-06	12-10	1/2"-3/8"	G 3/8	3/4-16 UNF	33.5	26	19	24	0.105
3420-08-08	12	1/2"	G 1/2	3/4-16 UNF	36.0	29	22	24	0.118
3420-10-06	16-10	5/8"-3/8"	G 3/8	7/8-14 UNF	39.0	27.5	22	27	0.135
3420-10-08	16-12	5/8"-1/2"	G 1/2	7/8-14 UNF	39.0	29	22	27	0.159
3420-10-12	16-20	5/8"-3/4"	G 3/4	7/8-14 UNF	41.5	33	27	27	0.178
3420-12-08	20-12	3/4"-1/2"	G 1/2	1 1/16-12 UN	44.0	31	27	36	0.211
3420-12-12	20	3/4"	G 3/4	1 1/16-12 UN	44.0	33	27	36	0.258
3420-16-12	25-20	1"-3/4"	G 3/4	1 5/16-12 UN	47.0	34	33	41	0.298
3420-16-16	25	1"	G 1	1 5/16-12 UN	47.0	35	33	41	0.367
3420-20-20	32	1.1/4"	G 1 1/4	1 5/8 UN	52.0	38	41	50	0.615
3420-24-24	38	1.1/2"	G 1 1/2	1 7/8-12 UN	55.0	41	50	55	0.994

Terminale a T Orientabile laterale M/M BSP- UNF (ISO 11926)

SDRT

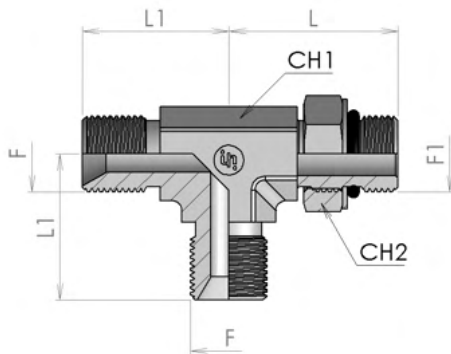

Part number	Dimensions								Weight kg/unit
	Ø		F	F1	L	L1	CH1	CH2	
	tube mm	tube inch							
3620-04-02	6	1/4"	G 1/8	7/16-20 UNF	27.0	22	12	17	0.041
3620-05-02	8-6	5/16"-1/4"	G 1/8	1/2-20 UNF	30.0	25	14	17	0.055
3620-06-04	10-8	3/8"-5/16"	G 1/4	9/16-18 UNF	33.0	27	14	19	0.071
3620-08-04	12-8	1/2"-5/16"	G 1/4	3/4-16 UNF	37.0	29.5	19	24	0.100
3620-08-06	12-10	1/2"-3/8"	G 3/8	3/4-16 UNF	37.0	32	19	24	0.140
3620-08-08	12	1/2"	G 1/2	3/4-16 UNF	37.0	36	22	24	0.157
3620-10-06	16-10	5/8"-3/8"	G 3/8	7/8-14 UNF	43.0	34	22	27	0.180
3620-10-08	16-12	5/8"-1/2"	G 1/2	7/8-14 UNF	43.0	36	22	27	0.212
3620-10-12	16-20	5/8"-3/4"	G 3/4	7/8-14 UNF	43.0	42	27	27	0.237
3620-12-08	20-12	3/4"-1/2"	G 1/2	1 1/16-12 UN	50.0	39	27	36	0.281
3620-12-12	20	3/4"	G 3/4	1 1/16-12 UN	50.0	42	27	36	0.344
3620-16-12	25-20	1"-3/4"	G 3/4	1 5/16-12 UN	53.0	44	33	41	0.397
3620-16-16	25	1"	G 1	1 5/16-12 UN	53.0	46	33	41	0.489
3620-20-20	32	1.1/4"	G 1 1/4	1 5/8 UN	58.0	52	41	50	0.820
3620-24-24	38	1.1/2"	G 1 1/2	1.7/8-12 UN	63.0	59	50	55	1.325

Terminale a T Orientabile centrale M/M BSP- UNF (ISO 11926)

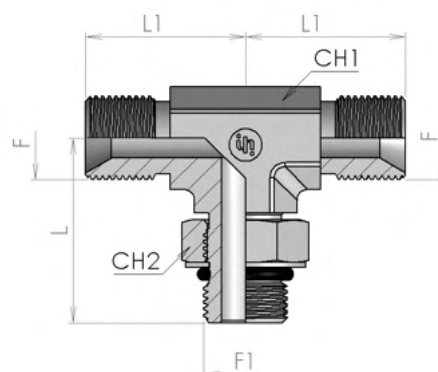
SDRT

Part number	Dimensions								Weight kg/unit
	Ø		F	F1	L	L1	CH1	CH2	
	tube mm	tube inch							
3625-04-02	6	1/4"	G 1/8	7/16-20 UNF	27.0	22	12	17	0.041
3625-05-02	8-6	5/16"-1/4"	G 1/8	1/2-20 UNF	30.0	25	14	17	0.055
3625-06-04	10-8	3/8"-5/16"	G 1/4	9/16-18 UNF	33.0	27	14	19	0.071
3625-08-04	12-8	1/2"-5/16"	G 1/4	3/4-16 UNF	37.0	29.5	19	24	0.100
3625-08-06	12-10	1/2"-3/8"	G 3/8	3/4-16 UNF	37.0	32	19	24	0.140
3625-08-08	12	1/2"	G 1/2	3/4-16 UNF	37.0	36	22	24	0.157
3625-10-06	16-10	5/8"-3/8"	G 3/8	7/8-14 UNF	43.0	34	22	27	0.180
3625-10-08	16-12	5/8"-1/2"	G 1/2	7/8-14 UNF	43.0	36	22	27	0.212
3625-10-12	16-20	5/8"-3/4"	G 3/4	7/8-14 UNF	43.0	42	27	27	0.237
3625-12-08	20-12	3/4"-1/2"	G 1/2	1 1/16-12 UN	50.0	39	27	36	0.281
3625-12-12	20	3/4"	G 3/4	1 1/16-12 UN	50.0	42	27	36	0.344
3625-16-12	25-20	1"-3/4"	G 3/4	1 5/16-12 UN	53.0	44	33	41	0.397
3625-16-16	25	1"	G 1	1 5/16-12 UN	53.0	46	33	41	0.489
3625-20-20	32	1.1/4"	G 1 1/4	1 5/8 UN	58.0	52	41	50	0.820
3625-24-24	38	1.1/2"	G 1 1/2	1.7/8-12 UN	63.0	59	50	55	1.325

Occhio filettato gas

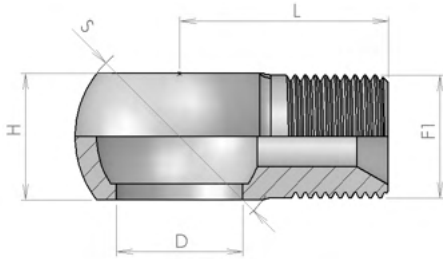

Part number	Dimensions					Weight kg/unit
	F1	D	L	H	S	
1550-04-04	G 1/4	G 1/4	22.0	14.5	24	0.030
1550-06-06	G 3/8	G 3/8	28.0	17	28	0.045
1550-08-06	G 3/8	G 1/2	32.5	22	36	0.086
1550-08-08	G 1/2	G 1/2	32.0	22	36	0.092
1550-12-12	G 3/4	G 3/4	40.0	29	45	0.166
1550-16-16	G 1	G 1	46.0	35	58	0.366

Occhio filettato gas con battuta

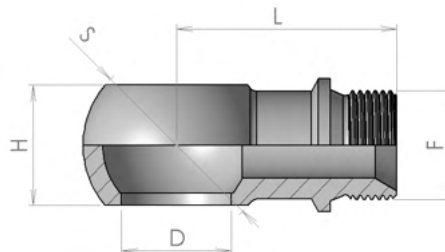

Part number	Dimensions				Weight kg/unit
	F	D	L	S	
1560-04-04	G 1/4	13.5	32.0	24	0.039
1560-06-06	G 3/8	17	38.0	28	0.058
1560-08-08	G 1/2	21	55.0	36	0.120
1560-12-12	G 3/4	26.5	53.0	45	0.216

Occhio a saldare gas

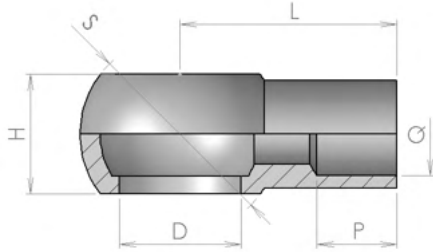

Part number	Dimensions					Weight kg/unit
	D	L	H	S	Q	
1450-04-08	G 1/4	24.0	14	24	8	0.034
1450-04-10	G 1/4	24.0	14	24	10	0.030
1450-06-12	G 3/8	28.0	17	28	12	0.039
1450-08-15	G 1/2	32.0	22	36	15	0.075
1450-08-16	G 1/2	32.0	22	36	16	0.073
1450-12-22	G 3/4	40.0	29	45	22	0.105
1450-16-27	G 1	45.0	35	58	27	0.170

Unione diretto maschio BSPT

S

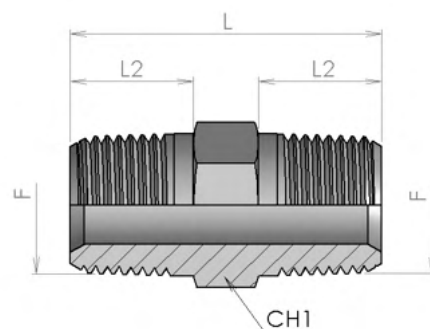

Part number	Dimensions						Weight kg/unit
	Ø		F	L	L2	CH1	
	tube mm	tube inch					
1860-02-02	6	1/4"	R 1/8 K	24.5	9.0	12	0.014
1860-04-04	8	5/16"	R 1/4 K	35.0	14.0	15	0.034
1860-06-06	10	3/8"	R 3/8 K	37.5	14.0	19	0.049
1860-08-08	12	1/2"	R 1/2 K	46.0	18.0	22	0.082
1860-12-12	20	3/4"	R 3/4 K	53.0	19.0	27	0.136
1860-16-16	25	1"	R 1 K	60.0	24.0	36	0.224
1860-20-20	32	1.1/4"	R 1 1/4 K	68.0	24.5	46	0.361
1860-24-24	38	1.1/2"	R 1 1/2 K	71.0	25.5	50	0.448
1860-32-32	50	2"	R 2 K	82.0	30.0	65	0.816

Unione a 90° maschio BSPT

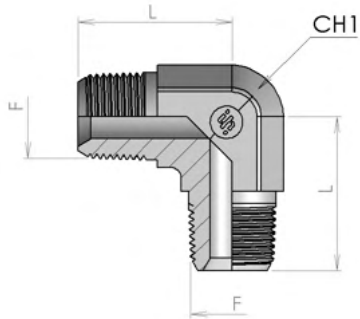

E

Part number	Dimensions					Weight kg/unit
	Ø		F	L	CH1	
	tube mm	tube inch				
4626-02	6	1/4"	R 1/8 K	19.5	12	0.015
4626-04	8	5/16"	R 1/4 K	27.5	14	0.042
4626-06	10	3/8"	R 3/8 K	31.0	19	0.093
4626-08	12	1/2"	R 1/2 K	36.0	22	0.142
4626-12	20	3/4"	R 3/4 K	40.5	27	0.231

Unione a 90° M BSPT F BSPP

E

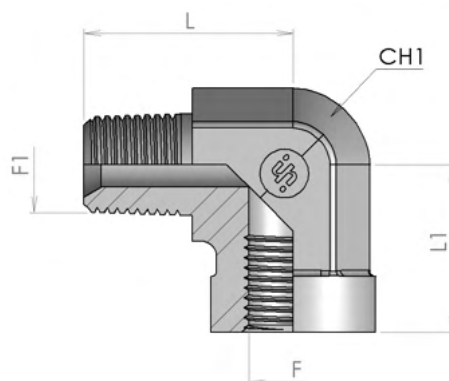

Part number	Dimensions							Weight kg/unit
	Ø		F	F1	L	L1	CH1	
	tube mm	tube inch						
4625-02	6	1/4"	G 1/8	R 1/8 K	23.5	17	14	0.048
4625-04	8	5/16"	G 1/4	R 1/4 K	29.0	22.5	19	0.065
4625-06	10	3/8"	G 3/8	R 3/8 K	33.5	26	22	0.008
4625-08	12	1/2"	G 1/2	R 1/2 K	38.0	31	27	0.147
4625-12	20	3/4"	G 3/4	R 3/4 K	45.0	34.5	33	0.210
4625-16	25	1"	G 1	R 1 K	55.0	41	41	0.402

Indice

1700	pag 6
1800	pag 7
R605	pag 8
2000	pag 9
2010	pag 10
2020	pag 11
A108	pag 12
A107	pag 13
4520	pag 14
4530	pag 15
4730	pag 16
4900	pag 17
4910	pag 18
4700	pag 19
4710	pag 20
4800	pag 21
4810	pag 22
4720	pag 23
2350	pag 24
4500	pag 25
4510	pag 26
3220	pag 27
3320	pag 28
2550	pag 29
2650	pag 30
2450	pag 31
4550	pag 32
2750	pag 33
2850	pag 34
4570	pag 35
4820	pag 36
A105	pag 37
A608	pag 38
A604	pag 39
A605	pag 40
MG	pag 41
220C	pag 42

Indice

2200	pag 43
1865	pag 44
2360	pag 45
4860	pag 46
4620	pag 47
4630	pag 48
4600	pag 49
4610	pag 50
1875	pag 51
2365	pag 52
4870	pag 53
4670	pag 54
4680	pag 55
4650	pag 56
1700E	pag 57
3900	pag 58
3255	pag 59
3950	pag 60
3600	pag 61
3605	pag 62
1805	pag 63
3510	pag 64
3910	pag 65
3410	pag 66
3610	pag 67
3615	pag 68
3520	pag 69
3920	pag 70
3420	pag 71
3620	pag 72
3625	pag 73
1550	pag 74
1560	pag 75
1450	pag 76
1860	pag 77
4626	pag 78
4625	pag 79

ORFS

in!

Nut

6010



Nuts

6

Sleeve

6015



Metric Sleeve

7

Union

6000

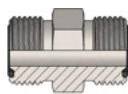

Male Union

8

6300



90° Union Elbow

9

6350



Union Tee

10

6550



Union Cross

11

Swivel

6120

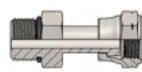

Swivel female-male

12

6036

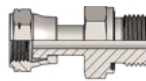

Swivel female-male
BSPP

13

6850

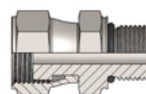

Swivel female
Male Metric

14

6060

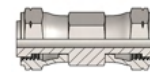

Straight swivel
nut union

15

6056

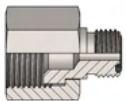

Reducing
male-female

16

6205

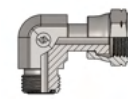

90° Swivel Elbow

17

6255



45° Swivel Elbow

18

6620



Swivel Run Tee

19

6630



Swivel Branch Tee

20

Bulkhead

6050

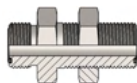

Bulkhead union

21

6510

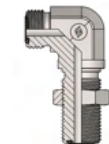

90° Bulkhead union

22

0107



Bulkhead locknut

23

ORFS/UNF

6150

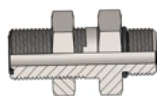

Bulkhead unions

24

6100

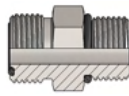

Male stud connectors

25

6200



90° Adjustable stud elbow

26

6250



45° Adjustable stud elbow

27

6400

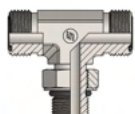

Adjustable stud Branch Tee

28

6450



Adjustable stud Run Tee

29

ORFS/BSPP

6805

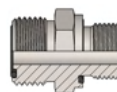

Male stud connector Form E

30

6800

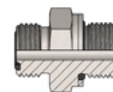

Male stud connector

31

6215



90° Adjustable stud elbow

32

6260



45° Adjustable stud elbow

33

6460



Adjustable stud Run Tee

34

6410

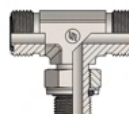

Adjustable stud Branch Tee

35

ORFS/METRIC

6840

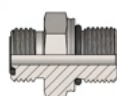

Male stud connector

36

6870



90° Adjustable stud elbow

37

6860



45° Adjustable stud elbow

38

6890

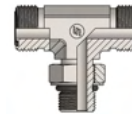

Adjustable stud Branch Tee

39

6880



Adjustable stud Run Tee

40

6905



Male stud connector

41

6900

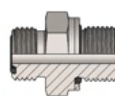

Male stud connector with O-ring and retaining ring

42

6320



90° Adjustable stud elbow with O-ring and retaining ring

43

6270



45° Adjustable stud elbow with O-ring and retaining ring

44

6420

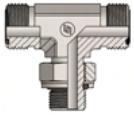

Adjustable stud
Branch Tee with O'ring
and retaining ring

45

6470



Adjustable stud
Run Tee with O'ring
and retaining ring

46



6830

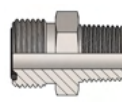

Male stud connector

47

6230



90° Male stud
elbows

48



6600

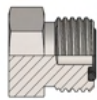

Male plug

49

6610



Female plug

50



M0

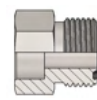

Braze-on straight
connector

51

Dado ORFS (ISO 8434-3)

NA

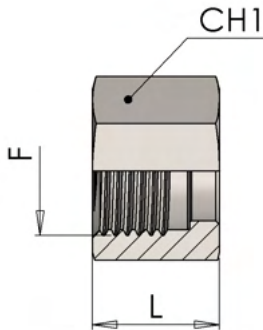

Part number	Dimensions					Weight kg/unit
	Ø		Thread			
	tube mm	tube inch	F	L	CH1	
6010-06	6	1/4"	9/16-18	15.0	17	0,014
6010-09	8-10	5/16"-3/8"	11/16-16	17.0	22	0,017
6010-11	12	1/2"	13/16-16	20.0	24	0,029
6010-13	14-16	5/8"	1-14	24.0	30	0,046
6010-14	18-20	3/4"	1.3/16-12	26.5	36	0,069
6010-15	22-25	1"	1.7/16-12	27.5	41	0,109
6010-21	28-32	1.1/4"	1.11/16-12	27.5	50	0,126
6010-32	35-38	1.1/2"	2-12	27.5	60	0,195

Bussola per tubo metrico

SL

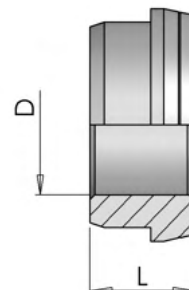

Part number	Dimensions			Weight kg/unit
	∅ tube mm	D	L	
6015-06	06	06	8.5	0,004
6015-08	08	08	9.5	0,004
6015-10	10	10	9.5	0,005
6015-12	12	12	11.5	0,006
6015-14	14	14	11.5	0,01
6015-15	15	15	11.5	0,009
6015-16	16	16	11.5	0,008
6015-18	18	18	13.0	0,014
6015-20	20	20	13.0	0,015
6015-22	22	22	14.5	0,02
6015-25	25	25	14.5	0,023
6015-28	28	28	14.0	0,024
6015-30	30	30	14.0	0,025
6015-32	32	32	14.0	0,026
6015-35	35	35	13.5	0,036
6015-38	38	38	13.5	0,044

Unione diretto maschio ORFS (ISO 8434-3)

S

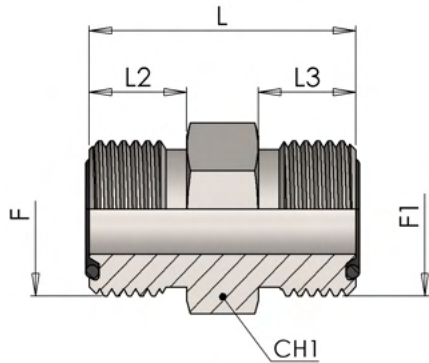

Part number	Dimensions								Weight kg/unit
	Ø		Thread						
	tube mm	tube inch	F	F1	L	L2	L3	CH1	
6000-06	6	1/4"	9/16-18	9/16-18	27.5	10	10	17	0,028
6000-09	8-10	5/16"-3/8"	11/16-16	11/16-16	31.0	11	11	19	0,049
6000-11	12	1/2"	13/16-16	13/16-16	35.5	13	13	22	0,077
6000-11-09	8-12	5/16"-1/2"	13/16-16	11/16-16	33.5	13	11	22	0,067
6000-13	14-16	5/8"	1-14	1-14	42.5	15.5	15.5	27	0,129
6000-13-11	12-16	5/8"-1/2"	1-14	13/16-16	40.0	15.5	13	27	0,112
6000-14	18-20	3/4"	1.3/16-12	1.3/16-12	47.0	17	17	32	0,204
6000-14-13	14-20	5/8"-3/4"	1.3/16-12	1-14	45.5	17	15.5	32	0,186
6000-15	22-25	1"	1.7/16-12	1.7/16-12	49.5	17.5	17.5	41	0,291
6000-15-14	18-25	3/4"-1"	1.7/16-12	1.3/16-12	49.0	17.5	17	41	0,285
6000-21	28-32	1.1/4"	1.11/16-12	1.11/16-12	51.5	17.5	17.5	46	0,299
6000-21-15	25-32	1.1/4"	1.11/16-12	1.7/16-12	51.5	17.5	17.5	46	0,28
6000-32	35-38	1.1/2"	2-12	2-12	53.0	17.5	17.5	55	0,552

Unione a 90° maschio ORFS (ISO 8434-3)

E

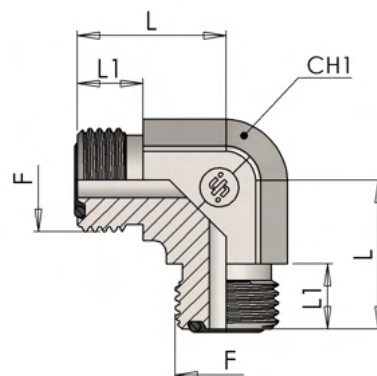

Part number	Dimensions						Weight kg/unit
	Ø		Thread				
	tube mm	tube inch	F	L	L1	CH1	
6300-06	6	1/4"	9/16-18	21.0	10	14	0,047
6300-09	8-10	5/16"-3/8"	11/16-16	25.0	11	19	0,109
6300-11	12	1/2"	13/16-16	28.0	13	19	0,123
6300-13	14-16	5/8"	1-14	33.5	15.5	27	0,183
6300-14	18-20	3/4"	1.3/16-12	37.5	17	27	0,18
6300-15	22-25	1"	1.7/16-12	41.5	17.5	36	0,45
6300-21	28-32	1.1/4"	1.11/16-12	44.5	17.5	41	0,53
6300-32	35-38	1.1/2"	2-12	49.0	17.5	50	0,7

Unione a T maschio ORFS (ISO 8434-3)

T

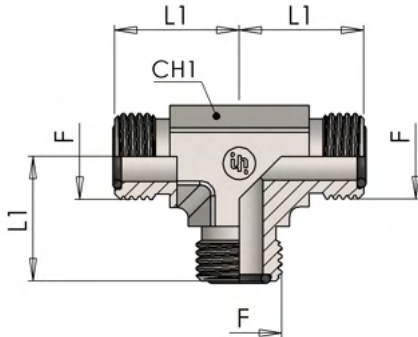

Part number	Dimensions					Weight kg/unit
	Ø		Thread			
	tube mm	tube inch	F	L1	CH1	
6350-06	6	1/4"	9/16-18	21	14	0,066
6350-09	8-10	5/16"-3/8"	11/16-16	25	19	0,114
6350-11	12	1/2"	13/16-16	28	19	0,199
6350-13	14-16	5/8"	1-14	33.5	27	0,239
6350-14	18-20	3/4"	1.3/16-12	37.5	27	0,321
6350-15	22-25	1"	1.7/16-12	41.5	36	0,488
6350-21	28-32	1.1/4"	1.11/16-12	44.5	41	0,768
6350-32	35-38	1.1/2"	2-12	49	50	0,866

Unione a croce maschio ORFS (ISO 8434-3)

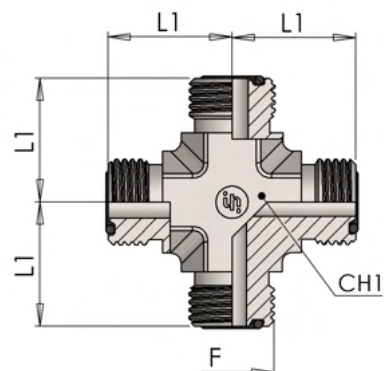
K

Part number	Dimensions					Weight kg/unit
	Ø		Thread	L1	CH1	
	tube mm	tube inch	F			
6550-06	6	1/4"	9/16-18	21	14	0,072
6550-09	8-10	5/16"-3/8"	11/16-16	25	19	0,14
6550-11	12	1/2"	13/16-16	28	19	0,225
6550-13	14-16	5/8"	1-14	33.5	27	0,288
6550-14	18-20	3/4"	1.3/16-12	37.5	27	0,32

Terminale dritto F/M ORFS-UNF (ISO 11926)

SDSWS

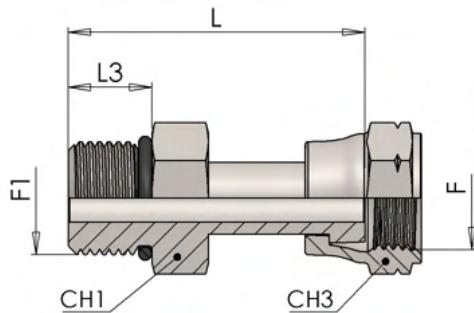

Part number	Dimensions								Weight kg/unit
	Ø		Thread						
	tube mm	tube inch	F	F1	L	L3	CH1	CH3	
6120-04-06	6	1/4"	9/16-18	7/16-20	37.0	11	17	17	0,053
6120-06-09	8-10	5/16"-3/8"	11/16-16	9/16-18	40.0	12	19	22	0,066
6120-08-11	12	1/2"	13/16-16	3/4-16	50.0	14	22	24	0,11
6120-10-13	14-16	5/8"	1-14	7/8-14	54.0	16	27	30	0,173
6120-12-14	18-20	3/4"	1.3/16-12	1.1/16-12	59.0	18.5	32	36	0,275
6120-16-15	22-25	1"	1.7/16-12	1.5/16-12	68.0	18.5	41	41	0,462
6120-20-21	28-32	1.1/4"	1.11/16-12	1.5/8-12	68.0	18.5	46	50	0,622

Terminale dritto F/M ORFS-BSP (Form E ISO 1179-2)

SWS

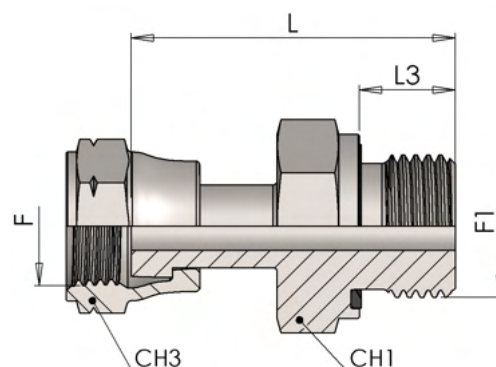

Part number	Dimensions								Weight kg/unit
	Ø		Thread						
	tube mm	tube inch	F	F1	L	L3	CH1	CH3	
6036-02-06	6	1/4"	9/16-18	G 1/8	34.0	8	14	17	0,043
6036-04-06	6	1/4"	9/16-18	G 1/4	38.0	12	19	17	0,059
6036-04-09	8-10	5/16"-3/8"	11/16-16	G 1/4	40.0	12	19	22	0,072
6036-04-11	12	1/2"	13/16-16	G 1/4	47.0	12	22	24	0,098
6036-06-09	8-10	5/16"-3/8"	11/16-16	G 3/8	40.0	12	22	22	0,086
6036-06-11	12	1/2"	13/16-16	G 3/8	47.0	12	22	24	0,104
6036-08-09	8-10	5/16"-3/8"	11/16-16	G 1/2	42.0	14	27	22	0,092
6036-08-11	12	1/2"	13/16-16	G 1/2	49.0	14	27	24	0,142
6036-08-13	14-16	5/8"	1-14	G 1/2	52.0	14	27	30	0,165
6036-12-13	14-16	5/8"	1-14	G 3/4	54.0	16	32	30	0,185
6036-12-14	18-20	3/4"	1.3/16-12	G 3/4	57.0	16	32	36	0,266
6036-16-15	22-25	1"	1.7/16-12	G 1	67.0	18	41	41	0,414
6036-20-21	28-32	1.1/4"	1.11/16-12	G 1 1/4	69.0	20	50	50	0,623
6036-24-32	35-38	1.1/2"	2-12	G 1 1/2	72.0	22	55	60	0,885

Terminale dritto F/M ORFS-METRICO (ISO 6149)

SDSWS

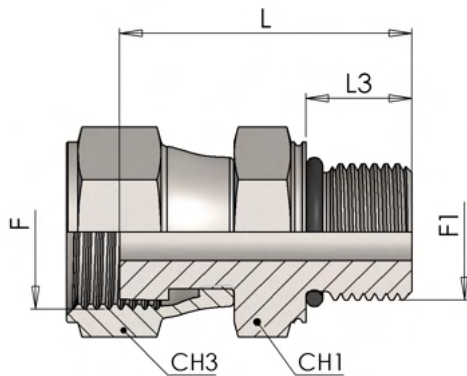

Part number	Dimensions								Weight kg/unit
	Ø		Thread						
	tube mm	tube inch	F	F1	L	L3	CH1	CH3	
6850-12-06	6	1/4"	9/16-18	M12x1,5	37.0	11	17	17	0,053
6850-16-09	8-10	5/16"-3/8"	11/16-16	M16x1,5	40.5	12.5	22	22	0,072
6850-18-11	12	1/2"	13/16-16	M18x1,5	49.5	14	24	24	0,11
6850-22-13	14-16	5/8"	1-14	M22x1,5	53.0	15	27	30	0,173
6850-27-14	18-20	3/4"	1.3/16-12	M27x2	59.5	18.5	32	36	0,275
6850-33-15	22-25	1"	1.7/16-12	M33x2	67.5	18.5	41	41	0,462
6850-42-21	28-32	1.1/4"	1.11/16-12	M42x2	68.0	19	50	50	0,622
6850-48-32	35-38	1.1/2"	2-12	M48x2	70.5	21.5	55	60	0,885

Unione diritto girevole ORFS (ISO 8434-3)

SWS

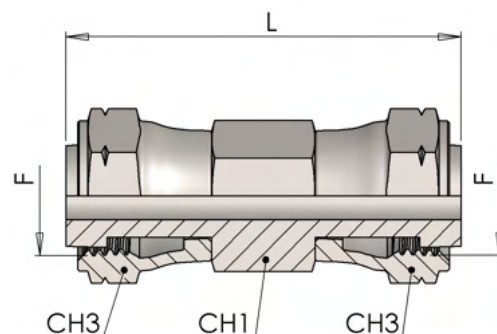

Part number	Dimensions						Weight kg/unit
	Ø		Thread				
	tube mm	tube inch	F	L	CH1	CH3	
6060-06-06	6	1/4"	9/16-18	40.4	17	17	0,053
6060-09-09	8-10	5/16"-3/8"	11/16-16	45.0	19	22	0,066
6060-11-11	12	1/2"	13/16-16	53.8	22	24	0,11
6060-13-13	14-16	5/8"	1-14	61.5	27	30	0,17
6060-14-14	18-20	3/4"	1.3/16-12	69.6	32	36	0,275

**Terminale dritto di riduzione F/M
ORFS
(ISO 8434-3)**

SRDS

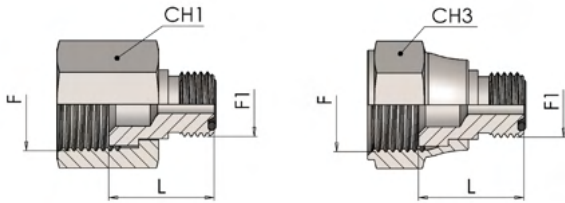

Part number	Dimensions							Weight kg/unit
	Ø		Thread		L	CH1	CH3	
	tube mm	tube inch	F	F1				
6056-09-06	10-06	3/8"-1/4"	11/16-16	9/16-18	19.5		22	0,021
6056-11-06	12-06	1/2"-1/4"	13/16-16	9/16-18	22.0	24		0,03
6056-11-09	12-10	1/2"-3/8"	13/16-16	11/16-16	22.5		24	0,033
6056-13-06	16-06	5/8"-1/4"	1-14	9/16-18	23.0	30		0,071
6056-13-09	16-08	5/8"-5/16"	1-14	11/16-16	24.0	30		0,073
6056-13-11	16-12	5/8"-1/2"	1-14	13/16-16	25.5	30		0,078
6056-14-06	20-06	3/4"-1/4"	1.3/16-12	9/16-18	25.0	36		0,085
6056-14-09	20-10	3/4"-3/8"	1.3/16-12	11/16-16	26.0	36		0,098
6056-14-11	20-12	3/4"-1/2"	1.3/16-12	13/16-16	27.5	36		0,105
6056-14-13	20-16	3/4"-5/8"	1.3/16-12	1-14	29.5		36	0,085
6056-15-11	25-12	1"-1/2"	1.7/16-12	13/16-16	29.0	41		0,135
6056-15-13	25-16	1"-5/8"	1.7/16-12	1-14	32.0	41		0,14
6056-15-14	25-20	1"-3/4"	1.7/16-12	1.3/16-12	33.0		41	0,133
6056-21-14	30-20	1.1/4"-3/4"	1.11/16-12	1.3/16-12	33.5	50		0,15
6056-21-15	30-25	1.1/4"-1"	1.11/16-12	1.7/16-12	38.5		50	0,2
6056-32-15	38-25	1.1/2"-1"	2-12	1.7/16-12	34.0	60		0,42
6056-32-21	38-30	1.1/2"-1.1/4"	2-12	1.11/16-12	34.0	60		0,42

Girevole a 90° F/M ORFS (ISO 8434-3)

SWE

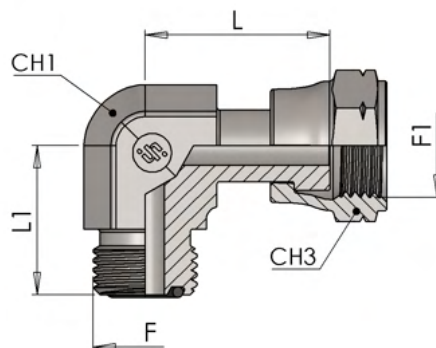

Part number	Dimensions								Weight kg/unit
	Ø		Thread						
	tube mm	tube inch	F	F1	L	L1	CH1	CH3	
6205-06	6	1/4"	9/16-18	9/16-18	27.5	21	14	17	0,045
6205-09	8-10	5/16"-3/8"	11/16-16	11/16-16	31.0	25	19	22	0,084
6205-11	12	1/2"	13/16-16	13/16-16	38.0	28	19	24	0,126
6205-13	14-16	5/8"	1-14	1-14	43.0	33.5	27	30	0,221
6205-14	18-20	3/4"	1.3/16-12	1.3/16-12	47.5	37.5	27	36	0,275
6205-15	22-25	1"	1.7/16-12	1.7/16-12	54.0	41.5	36	41	0,541
6205-21	28-32	1.1/4"	1.11/16-12	1.11/16-12	59.0	44.5	41	50	0,557
6205-32	35-38	1.1/2"	2-12	2-12	62.0	49	50	60	0,75

6255

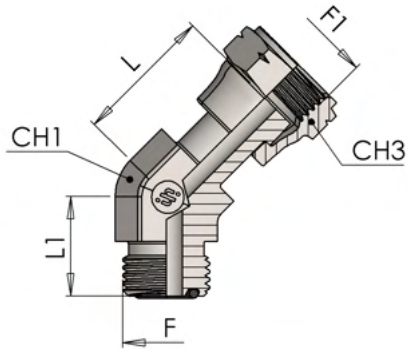

**Girevole a 45° F/M
ORFS
(ISO 8434-3)**

SWE45

Part number	Dimensions								Weight kg/unit
	Ø		Thread						
	tube mm	tube inch	F	F1	L	L1	CH1	CH3	
6255-06	6	1/4"	9/16-18	9/16-18	22.0	16	14	17	0,044
6255-09	8-10	5/16"-3/8"	11/16-16	11/16-16	26.5	19	19	22	0,082
6255-11	12	1/2"	13/16-16	13/16-16	31.0	20.5	19	24	0,11
6255-13	14-16	5/8"	1-14	1-14	36.5	23.5	27	30	0,19
6255-14	18-20	3/4"	1.3/16-12	1.3/16-12	41.5	26	27	36	0,215
6255-15	22-25	1"	1.7/16-12	1.7/16-12	46.5	30	36	41	0,3
6255-21	28-32	1.1/4"	1.11/16-12	1.11/16-12	46.5	32	41	50	0,5
6255-32	35-38	1.1/2"	2-12	2-12	48.5	37	50	60	0,745

Girevole a T laterale F/M ORFS (ISO 8434-3)

SWRT

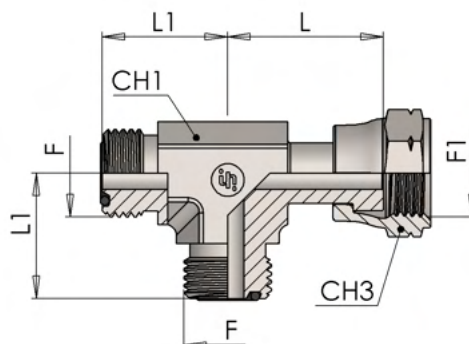

Part number	Dimensions								Weight kg/unit
	Ø		Thread						
	tube mm	tube inch	F	F1	L	L1	CH1	CH3	
6620-06	6	1/4"	9/16-18	9/16-18	27.5	21	14	17	0,066
6620-09	8-10	5/16"-3/8"	11/16-16	11/16-16	31.0	25	19	22	0,125
6620-11	12	1/2"	13/16-16	13/16-16	38.0	28	19	24	0,15
6620-13	14-16	5/8"	1-14	1-14	43.0	33.5	27	30	0,233
6620-14	18-20	3/4"	1.3/16-12	1.3/16-12	47.5	37.5	27	36	0,28
6620-15	22-25	1"	1.7/16-12	1.7/16-12	54.0	41.5	36	41	0,505
6620-21	28-32	1.1/4"	1.11/16-12	1.11/16-12	59.0	44.5	41	50	0,775
6620-32	35-38	1.1/2"	2-12	2-12	62.0	49	50	60	0,965

6630

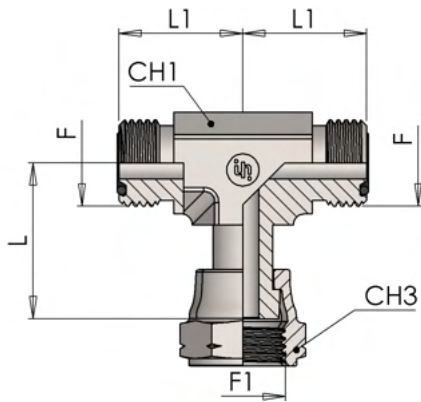

**Girevole a T centrale F/M
ORFS
(ISO 8434-3)**

SWBT

Part number	Dimensions								Weight kg/unit
	Ø		Thread		L	L1	CH1	CH3	
	tube mm	tube inch	F	F1					
6630-06	6	1/4"	9/16-18	9/16-18	27.5	21	14	17	0,066
6630-09	8-10	5/16"-3/8"	11/16-16	11/16-16	31.0	25	19	22	0,125
6630-11	12	1/2"	13/16-16	13/16-16	38.0	28	19	24	0,15
6630-13	14-16	5/8"	1-14	1-14	43.0	33.5	27	30	0,233
6630-14	18-20	3/4"	1.3/16-12	1.3/16-12	47.5	37.5	27	36	0,28
6630-15	22-25	1"	1.7/16-12	1.7/16-12	54.0	41.5	36	41	0,505
6630-21	28-32	1.1/4"	1.11/16-12	1.11/16-12	59.0	44.5	41	50	0,775
6630-32	35-38	1.1/2"	2-12	2-12	62.0	49	50	60	0,965

Passaparete dritto ORFS (ISO 8434-3)

BHS

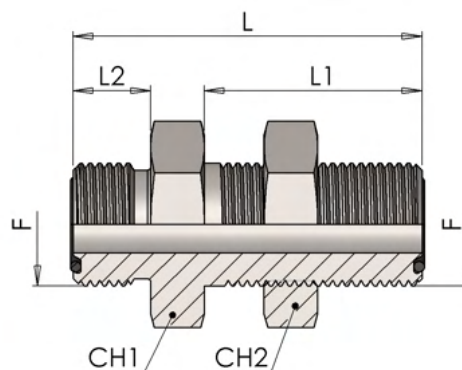

Part number	Dimensions								Weight kg/unit
	Ø		Thread						
	tube mm	tube inch	F	L	L1	L2	CH1	CH2	
6050-06	6	1/4"	9/16-18	48.0	31.5	10	22	22	0,08
6050-09	8-10	5/16"-3/8"	11/16-16	53.0	34	11	27	27	0,14
6050-11	12	1/2"	13/16-16	58.5	36.5	13	30	30	0,155
6050-13	14-16	5/8"	1-14	66.5	40.5	15.5	36	36	0,31
6050-14	18-20	3/4"	1.3/16-12	69.0	41.5	17	41	41	0,34
6050-15	22-25	1"	1.7/16-12	70.0	42	17.5	46	46	0,436
6050-21	28-32	1.1/4"	1.11/16-12	70.0	42	17.5	50	50	0,51
6050-32	35-38	1.1/2"	2-12	70.0	42	17.5	60	60	0,674

**Passaparete a 90° ORFS
(ISO 8434-3)**

BHE

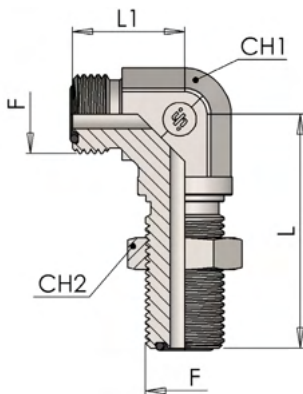

Part number	Dimensions							Weight kg/unit
	Ø		Thread					
	tube mm	tube inch	F	L	L1	CH1	CH2	
6510-06	6	1/4"	9/16-18	47.0	21	14	22	0,078
6510-09	8-10	5/16"-3/8"	11/16-16	52.0	25	19	27	0,146
6510-11	12	1/2"	13/16-16	55.0	28	19	30	0,252
6510-13	14-16	5/8"	1-14	63.0	35	27	36	0,287
6510-14	18-20	3/4"	1.3/16-12	67.0	38	27	41	0,31
6510-15	22-25	1"	1.7/16-12	71.0	41.5	36	46	0,64

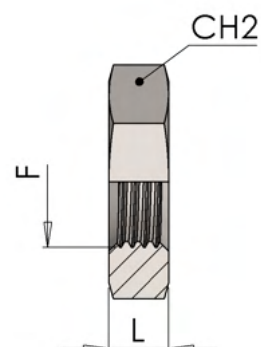
Controdado per passaparete
BHLN

Part number	Dimensions			Weight kg/unit
	Thread			
	F	L	CH2	
O107-06	9/16-18	7.0	22	0,011
O107-09	11/16-16	8.0	27	0,025
O107-11	13/16-16	9.0	30	0,031
O107-13	1-14	11.0	36	0,053
O107-14	1.3/16-12	11.0	41	0,064
O107-15	1.7/16-12	11.0	46	0,068
O107-21	1.11/16-12	11.0	50	0,070
O107-32	2-12	11.0	60	0,100

Passaparete dritto ORFS/UNF (ISO 11926)

BHS

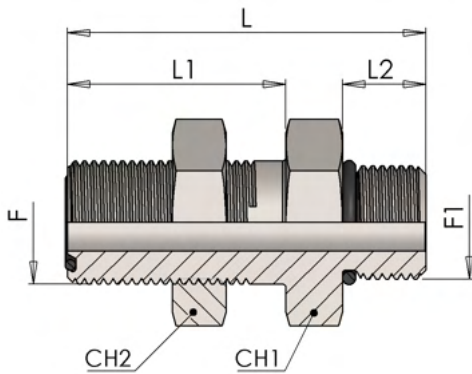

Part number	Dimensions									Weight kg/unit
	Ø		Thread							
	tube mm	tube inch	F	F1	L	L1	L2	CH1	CH2	
6150-04-06	6	1/4"	9/16-18	7/16-20	54.0	31.5	11	22	22	0,075
6150-06-09	8-10	5/16"-3/8"	11/16-16	9/16-18	58.0	34	12	27	27	0,112
6150-08-11	12	1/2"	13/16-16	3/4-16	65.0	36.5	14	30	30	0,147
6150-10-13	14-16	5/8"	1-14	7/8-14	67.0	40.5	16	36	36	0,295
6150-12-14	18-20	3/4"	1.3/16-12	1.1/16-12	71.0	41.5	18.5	41	41	0,33

Terminale dritto M/M ORFS-UNF (ISO 11926)

SDS

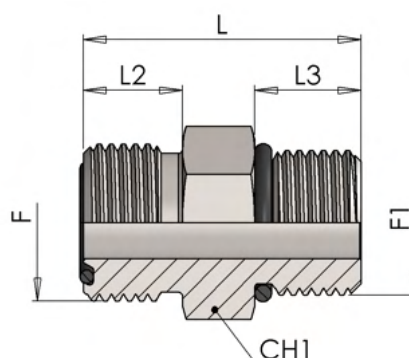

Part number	Dimensions								Weight kg/unit
	Ø		Thread						
	tube mm	tube inch	F	F1	L	L2	L3	CH1	
6100-04-06	6	1/4"	9/16-18	7/16-20	29.0	10	11	17	0,03
6100-06-06	6	1/4"	9/16-18	9/16-18	31.0	10	12	19	0,036
6100-06-09	8-10	5/16"-3/8"	11/16-16	9/16-18	32.0	11	12	19	0,045
6100-08-11	12	1/2"	13/16-16	3/4-16	37.0	13	14	22	0,067
6100-10-09	8-10	5/16"-3/8"	11/16-16	7/8-14	39.0	11	16	27	0,089
6100-10-13	14-16	5/8"	1-14	7/8-14	43.0	15.5	16	27	0,109
6100-10-14	18-20	3/4"	1.3/16-12	7/8-14	51.0	17	16	32	0,177
6100-12-14	18-20	3/4"	1.3/16-12	1.1/16-12	49.0	17	18.5	32	0,173
6100-12-15	22-25	1"	1.7/16-12	1.1/16-12	55.0	17.5	18.5	41	0,287
6100-16-14	18-20	3/4"	1.3/16-12	1.5/16-12	50.0	17	18.5	41	0,254
6100-16-15	22-25	1"	1.7/16-12	1.5/16-12	50.0	17.5	18.5	41	0,29
6100-20-15	22-25	1"	1.7/16-12	1.5/8-12	52.5	17.5	18.5	46	0,428
6100-20-21	28-32	1.1/4"	1.11/16-12	1.5/8-12	52.5	17.5	18.5	46	0,416
6100-24-32	35-38	1.1/2"	2-12	1.7/8-12	54.0	17.5	18.5	55	0,612

Curva Orientabile 90° M/M ORFS-UNF (ISO 11926)

SDE

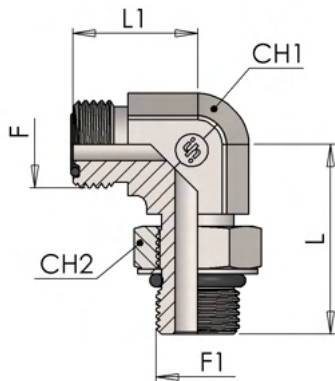

Part number	Dimensions								Weight kg/unit
	Ø		Thread						
	tube mm	tube inch	F	F1	L	L1	CH1	CH2	
6200-04-06	6	1/4"	9/16-18	7/16-20	32.0	21	14	17	0,053
6200-06-06	6	1/4"	9/16-18	9/16-18	37.0	23	19	19	0,066
6200-06-09	8-10	5/16"-3/8"	11/16-16	9/16-18	37.0	25	19	19	0,068
6200-08-11	12	1/2"	13/16-16	3/4-16	41.0	28	19	24	0,164
6200-10-13	14-16	5/8"	1-14	7/8-14	50.0	33.5	27	27	0,214
6200-12-14	18-20	3/4"	1.3/16-12	1.1/16-12	55.0	37.5	27	36	0,35
6200-16-15	22-25	1"	1.7/16-12	1.5/16-12	59.0	41.5	36	41	0,49
6200-20-21	28-32	1.1/4"	1.11/16-12	1.5/8-12	62.0	44.5	41	50	0,695
6200-24-32	35-38	1.1/2"	2-12	1.7/8-12	67.0	49	50	55	0,775

Curva Orientabile 45° M/M ORFS-UNF (ISO 11926)

SDE45

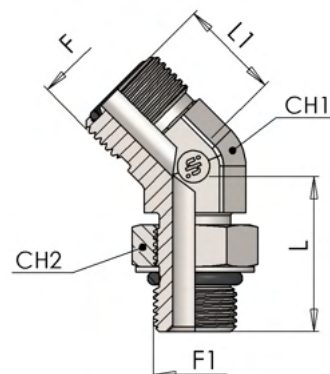

Part number	Dimensions								Weight kg/unit
	Ø		Thread						
	tube mm	tube inch	F	F1	L	L1	CH1	CH2	
6250-04-06	6	1/4"	9/16-18	7/16-20	30.0	18	14	17	0,045
6250-04-09	8-10	5/16"-3/8"	11/16-16	7/16-20	31.5	19.5	19	17	0.064
6250-06-09	8-10	5/16"-3/8"	11/16-16	9/16-18	33.0	19.5	19	19	0,083
6250-08-09	8-10	5/16"-3/8"	11/16-16	3/4-16	37.0	19	19	24	0.096
6250-08-11	12	1/2"	13/16-16	3/4-16	37.0	22	19	24	0,117
6250-08-13	14-16	5/8"	1-14	3/4-16	40.5	26	27	24	0.192
6250-10-13	14-16	5/8"	1-14	7/8-14	44.0	26	27	27	0,194
6250-12-14	18-20	3/4"	1.3/16-12	1.1/16-12	50.0	27	27	36	0,294
6250-16-15	22-25	1"	1.7/16-12	1.5/16-12	52.5	30	36	41	0,394
6250-20-21	28-32	1.1/4"	1.11/16-12	1.5/8-12	53.5	32	41	50	0,447

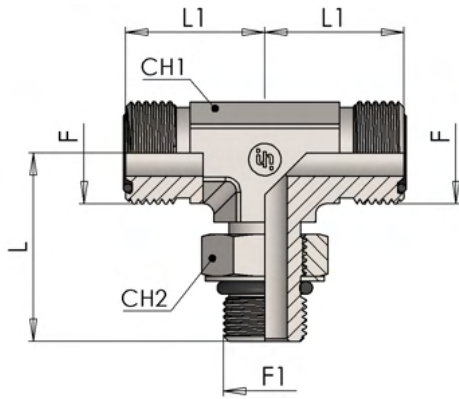

Terminale a T orientabile centrale M/M ORFS-UNF (ISO 11926)

SDBT

Part number	Dimensions								Weight kg/unit
	Ø		Thread						
	tube mm	tube inch	F	F1	L	L1	CH1	CH2	
6400-04-06	6	1/4"	9/16-18	7/16-20	32.0	21	14	17	0,067
6400-06-09	8-10	5/16"-3/8"	11/16-16	9/16-18	37.0	25	19	19	0,131
6400-08-11	12	1/2"	13/16-16	3/4-16	41.0	28	19	24	0,187
6400-10-13	14-16	5/8"	1-14	7/8-16	50.0	33.5	27	27	0,279
6400-12-14	18-20	3/4"	1.3/16-12	1.1/16-12	55.0	37.5	27	36	0,441
6400-16-15	22-25	1"	1.7/16-12	1.5/16-12	59.0	41.5	36	41	0,539
6400-20-21	28-32	1.1/4"	1.11/16-12	1.5/8-12	62.0	44.5	41	50	0,851
6400-24-32	35-38	1.1/2"	2-12	1.7/8-12	67.0	49	50	55	0,942

Terminale a T orientabile laterale M/M ORFS-UNF (ISO 11926)

SDRT

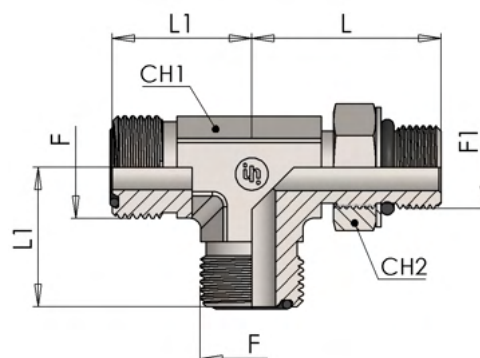

Part number	Dimensions								Weight kg/unit
	Ø		Thread						
	tube mm	tube inch	F	F1	L	L1	CH1	CH2	
6450-04-06	6	1/4"	9/16-18	7/16-20	32.0	21	14	17	0,067
6450-06-09	8-10	5/16"-3/8"	11/16-16	9/16-18	37.0	25	19	19	0,131
6450-08-11	12	1/2"	13/16-16	3/4-16	41.0	28	19	24	0,187
6450-10-13	14-16	5/8"	1-14	7/8-16	50.0	33.5	27	27	0,279
6450-12-14	18-20	3/4"	1.3/16-12	1.1/16-12	55.0	37.5	27	36	0,441
6450-16-15	22-25	1"	1.7/16-12	1.5/16-12	59.0	41.5	36	41	0,539
6450-20-21	28-32	1.1/4"	1.11/16-12	1.5/8-12	62.0	44.5	41	50	0,851
6450-24-32	35-38	1.1/2"	2-12	1.7/8-12	67.0	49	50	55	0,942

Terminale dritto M/M ORFS-BSPB (Form E ISO 1179-2)

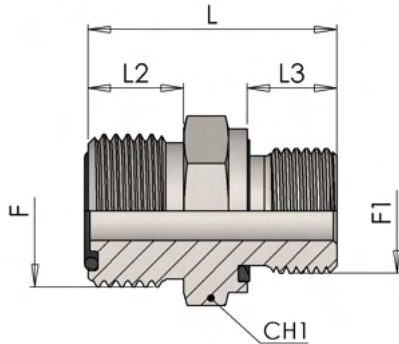

SDS

Part number	Dimensions								Weight kg/unit
	Ø		Thread						
	tube mm	tube inch	F	F1	L	L2	L3	CH1	
6805-02-06	6	1/4"	9/16-18	G 1/8	25.0	10	8	17	0,029
6805-04-06	6	1/4"	9/16-18	G 1/4	30.5	10	12	19	0,042
6805-04-09	8-10	5/16"-3/8"	11/16-16	G 1/4	31.5	11	12	19	0,045
6805-04-11	12	1/2"	13/16-16	G 1/4	33.0	13	12	22	0,04
6805-06-06	6	1/4"	9/16-18	G 3/8	30.5	10	12	22	0,061
6805-06-09	8-10	5/16"-3/8"	11/16-16	G 3/8	31.5	11	12	22	0,063
6805-06-11	12	1/2"	13/16-16	G 3/8	33.5	13	12	22	0,06
6805-06-13	14-16	5/8"	1-14	G 3/8	37.0	15.5	12	27	0,093
6805-08-09	8-10	5/16"-3/8"	11/16-16	G 1/2	35.0	11	14	27	0,052
6805-08-11	12	1/2"	13/16-16	G 1/2	37.0	13	14	27	0,09
6805-08-13	14-16	5/8"	1-14	G 1/2	39.5	15.5	14	27	0,11
6805-08-14	18-20	3/4"	1.3/16-12	G 1/2	43.0	17	14	32	0,147
6805-12-11	12	1/2"	13/16-16	G 3/4	41.0	13	16	32	0,151
6805-12-13	14-16	5/8"	1-14	G 3/4	43.5	15.5	16	32	0,154
6805-12-14	18-20	3/4"	1.3/16-12	G 3/4	45.0	17	16	32	0,164
6805-12-15	22-25	1"	1.7/16-12	G 3/4	46.0	17.5	16	41	0,236
6805-16-13	14-16	5/8"	1-14	G 1	46.0	15.5	18	41	0,271
6805-16-14	18-20	3/4"	1.3/16-12	G 1	47.5	17	18	41	0,276
6805-16-15	22-25	1"	1.7/16-12	G 1	48.0	17.5	18	41	0,37
6805-16-21	28-32	1.1/4"	1.11/16-12	G 1	49.5	17.5	18	46	0,505
6805-20-15	22-25	1"	1.7/16-12	G 1.1/4	51.5	17.5	20	50	0,487
6805-20-21	28-32	1.1/4"	1.11/16-12	G 1.1/4	51.5	17.5	20	50	0,532
6805-24-32	35-38	1.1/2"	2-12	G 1.1/2	55.5	17.5	22	55	0,585

Terminale dritto M/M ORFS-BSPP (ISO 1179)

SDS

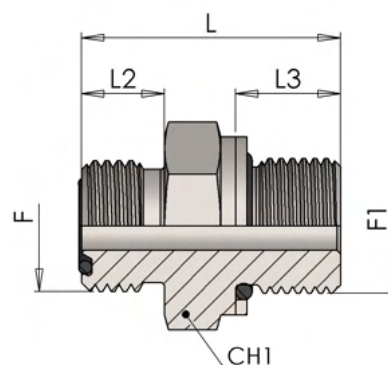

Part number	Dimensions								Weight kg/unit
	Ø		Thread		L	L2	L3	CH1	
	tube mm	tube inch	F	F1					
6800-02-06	6	1/4"	9/16-18	G 1/8	25.0	10	8	17	0,029
6800-04-06	6	1/4"	9/16-18	G 1/4	30.5	10	12	19	0,042
6800-04-09	8-10	5/16"-3/8"	11/16-16	G 1/4	31.5	11	12	19	0,045
6800-04-11	12	1/2"	13/16-16	G 1/4	33.5	13	12	22	0,04
6800-06-06	6	1/4"	9/16-18	G 3/8	30.5	10	12	22	0,061
6800-06-09	8-10	5/16"-3/8"	11-16-16	G 3/8	31.5	11	12	22	0,063
6800-06-11	12	1/2"	13/16-16	G 3/8	33.5	13	12	22	0,06
6800-06-13	14-16	5/8"	1-14	G 3/8	37.5	15.5	12	27	0,093
6800-08-09	8-10	5/16"-3/8"	11/16-16	G 1/2	35.5	11	14.5	27	0,052
6800-08-11	12	1/2"	13/16-16	G 1/2	37.5	13	14.5	27	0,09
6800-08-13	14-16	5/8"	1-14	G 1/2	40.0	15.5	14.5	27	0,11
6800-08-14	18-20	3/4"	1.3/16-12	G 1/2	41.5	17	14.5	32	0,147
6800-12-13	14-16	5/8"	1-14	G 3/4	43.5	15.5	16	36	0,154
6800-12-14	18-20	3/4"	1.3/16-12	G 3/4	45.0	17	16	36	0,164
6800-12-15	22-25	1"	1.7/16-12	G 3/4	45.5	17.5	16	41	0,236
6800-16-14	18-20	3/4"	1.3/16-12	G 1	47.5	17	18	41	0,271
6800-16-15	22-25	1"	1.7/16-12	G 1	48.0	17.5	18	41	0,276
6800-16-21	28-32	1.1/4"	1.11/16-12	G 1	49.5	17.5	18	46	0,37
6800-20-15	18-20	3/4"	1.3/16-12	G 1.1/4	51.5	17.5	20	50	0,505
6800-20-21	22-25	1"	1.7/16-12	G 1.1/4	51.5	17.5	20	50	0,487
6800-24-21	22-25	1"	1.11/16-12	G 1.1/2	55.5	17.5	22	55	0,532
6800-24-32	35-38	1.1/2"	2-12	G 1.1/2	55.5	17.5	22	55	0,585

Curva Orientabile 90° M/M ORFS-BSP (ISO 1179)

SDE

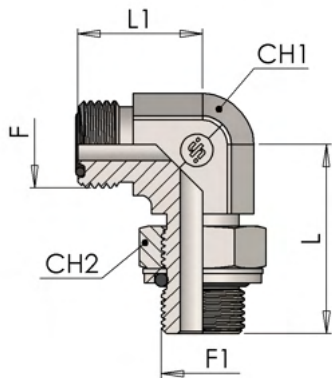

Part number	Dimensions								Weight kg/unit
	Ø		Thread						
	tube mm	tube inch	F	F1	L	L1	CH1	CH2	
6215-02-06	6	1/4"	9/16-18	G 1/8	30.0	21	14	14	0,049
6215-04-06	6	1/4"	9/16-18	G 1/4	37.0	23	19	19	0,093
6215-04-09	8-10	5/16"-3/8"	11/16-16	G 1/4	37.0	25	19	19	0,097
6215-04-11	12	1/2"	13/16-16	G 1/4	37.0	28	19	19	0,108
6215-06-06	6	1/4"	9/16-18	G 3/8	38.0	23	19	22	0,099
6215-06-09	8-10	5/16"-3/8"	11/16-16	G 3/8	38.0	25	19	22	0,106
6215-06-11	12	1/2"	13/16-16	G 3/8	38.0	28	19	22	0,108
6215-06-13	14-16	5/8"	1-14	G 3/8	43.0	33.5	27	22	0,235
6215-08-09	8-10	5/16"-3/8"	11/16-16	G 1/2	48.0	29.5	27	27	0,12
6215-08-11	12	1/2"	13/16-16	G 1/2	48.0	30.5	27	27	0,239
6215-08-13	14-16	5/8"	1-14	G 1/2	48.0	33.5	27	27	0,274
6215-08-14	18-20	3/4"	1.3/16-12	G 1/2	48.0	37.5	27	27	0,297
6215-12-11	12	1/2"	13/16-16	G 3/4	51.5	32	27	36	0,258
6215-12-13	14-16	5/8"	1-14	G 3/4	51.5	33.5	27	36	0,352
6215-12-14	18-20	3/4"	1.3/16-12	G 3/4	51.5	37.5	27	36	0,355
6215-12-15	22-25	1"	1.7/16-12	G 3/4	54.5	41.5	36	36	0,533
6215-16-14	18-20	3/4"	1.3/16-12	G 1	59.0	39.5	36	41	0,362
6215-16-15	22-25	1"	1.7/16-12	G 1	59.0	41.5	36	41	0,551
6215-16-21	28-32	1.1/4"	1.11/16-12	G 1	60.5	44.5	41	41	0,712
6215-20-15	22-25	1"	1.7/16-12	G 1.1/4	62.0	43	41	50	0,758
6215-20-21	28-32	1.1/4"	1.11/16-12	G 1.1/4	62.0	44.5	41	50	0,752
6215-24-21	28-32	1.1/4"	1.11/16-12	G 1.1/2	65.0	46.5	50	55	0.821
6215-24-32	35-38	1.1/2"	2-12	G 1.1/2	65.0	49	50	55	0,953

Curva Orientabile 45° M/M
ORFS-BSP
(ISO 1179)

SDE45

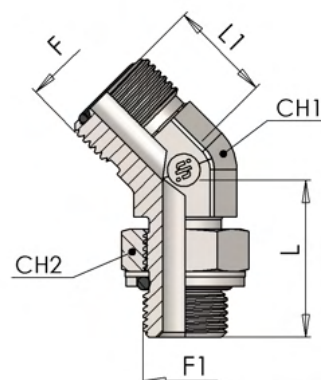

Part number	Dimensions								Weight kg/unit
	Ø		Thread						
	tube mm	tube inch	F	F1	L	L1	CH1	CH2	
6260-02-06	6	1/4"	9/16-18	G 1/8	28.0	18	14	14	0,038
6260-04-06	6	1/4"	9/16-18	G 1/4	32.5	18.5	19	19	0,055
6260-04-09	8-10	5/16"-3/8"	11/16-16	G 1/4	32.5	19.5	19	19	0,083
6260-06-09	8-10	5/16"-3/8"	11/16-16	G 3/8	33.5	19.5	19	22	0,095
6260-06-11	12	1/2"	13/16-16	G 3/8	33.5	22	19	22	0,117
6260-08-09	8-10	5/16"-3/8"	11/16-16	G 1/2	42.0	22.5	27	27	0,107
6260-08-13	14-16	5/8"	1-14	G 1/2	42.0	26	27	27	0,191
6260-12-13	14-16	5/8"	1-14	G 3/4	46.0	26	27	36	0,205
6260-12-14	18-20	3/4"	1.3/16-12	G 3/4	46.0	27	27	36	0,245
6260-16-14	18-20	3/4"	1.3/16-12	G 1	51.0	29.5	36	41	0,325
6260-16-15	22-25	1"	1.7/16-12	G 1	51.0	30	36	41	0,394
6260-20-21	28-32	1.1/4"	1.11/16-12	G 1.1/4	52.0	32	41	50	0,43

Terminale a T orientabile laterale M/M ORFS-BSP (ISO 1179)

SDRT

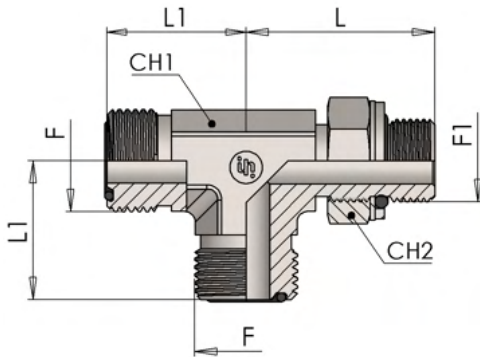

Part number	Dimensions								Weight kg/unit
	Ø		Thread		L	L1	CH1	CH2	
	tube mm	tube inch	F	F1					
6460-02-06	6	1/4"	9/16-18	G 1/8	30.0	21	14	14	0,069
6460-04-06	6	1/4"	9/16-18	G 1/4	37.0	23	19	19	0,097
6460-04-09	8-10	5/16"-3/8"	11/16-16	G 1/4	37.0	25	19	19	0,127
6460-06-06	6	1/4"	9/16-18	G 3/8	38.0	23	19	22	0,11
6460-06-09	8-10	5/16"-3/8"	11/16-16	G 3/8	38.0	25	19	22	0,126
6460-06-11	12	1/2"	13/16-16	G 3/8	38.0	28	19	22	0,146
6460-08-11	12	1/2"	13/16-16	G 1/2	48.0	30.5	27	27	0,174
6460-08-13	14-16	5/8"	1-14	G 1/2	48.0	33.5	27	27	0,288
6460-12-13	14-16	5/8"	1-14	G 3/4	51.5	33.5	27	36	0,31
6460-12-14	18-20	3/4"	1.3/16-12	G 3/4	51.5	37.5	27	36	0,49
6460-16-15	22-25	1"	1.7/16-12	G 1	59.0	41.5	36	41	0,55
6460-20-21	28-32	1.1/4"	1.11/16-12	G 1.1/4	62.0	44.5	41	50	0,825
6460-24-32	35-38	1.1/2"	2-12	G 1.1/2	65.0	49	50	55	0,95

Terminale a T orientabile centrale M/M ORFS-BSP (ISO 1179)

SDBT

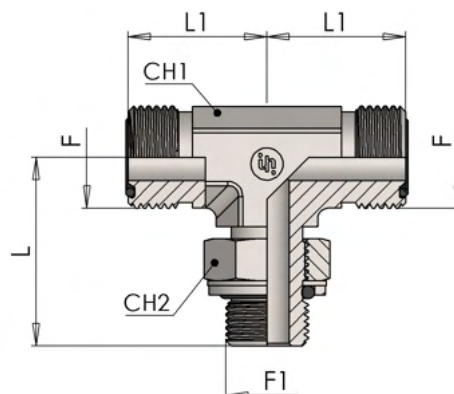

Part number	Dimensions								Weight kg/unit
	Ø		Thread						
	tube mm	tube inch	F	F1	L	L1	CH1	CH2	
6410-02-06	6	1/4"	9/16-18	G 1/8	30.0	21	14	14	0,069
6410-04-06	6	1/4"	9/16-18	G 1/4	37.0	23	19	19	0,097
6410-04-09	8-10	5/16"-3/8"	11/16-16	G 1/4	37.0	25	19	19	0,127
6410-06-06	6	1/4"	9/16-18	G 3/8	38.0	23	19	22	0,11
6410-06-09	8-10	5/16"-3/8"	11/16-16	G 3/8	38.0	25	19	22	0,126
6410-06-11	12	1/2"	13/16-16	G 3/8	38.0	28	19	22	0,146
6410-08-11	12	1/2"	13/16-16	G 1/2	48.0	30.5	27	27	0,174
6410-08-13	14-16	5/8"	1-14	G 1/2	48.0	33.5	27	27	0,288
6410-12-13	14-16	5/8"	1-14	G 3/4	51.5	33.5	27	36	0,31
6410-12-14	18-20	3/4"	1.3/16-12	G 3/4	51.5	37.5	27	36	0,49
6410-16-15	22-25	1"	1.7/16-12	G 1	59.0	41.5	36	41	0,55
6410-20-21	28-32	1.1/4"	1.11/16-12	G 1.1/4	62.0	44.5	41	50	0,825
6410-24-32	35-38	1.1/2"	2-12	G 1.1/2	65.0	49	50	55	0,95

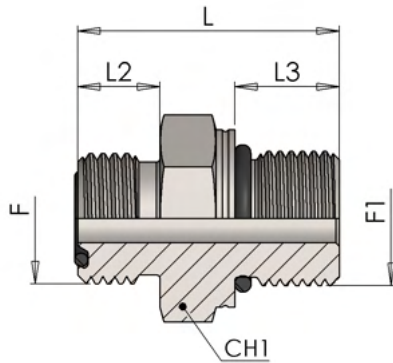

Terminale dritto M/M ORFS-METRICO (ISO 6149)

SDS

Part number	Dimensions								Weight kg/unit
	Ø		Thread						
	tube mm	tube inch	F	F1	L	L2	L3	CH1	
6840-10-06	6	1/4"	9/16-18	M10x1	26.0	10	9.5	17	0,02
6840-12-06	6	1/4"	9/16-18	M12x1.5	28.5	10	11	17	0,024
6840-12-09	8-10	5/16"-3/8"	11/16-16	M12x1.5	30.5	11	11	19	0,04
6840-14-06	6	1/4"	9/16-18	M14x1,5	29.5	10	11	19	0,03
6840-14-09	8-10	5/16"-3/8"	11/16-16	M14x1,5	30.5	11	11	19	0,043
6840-14-11	12	1/2"	13/16-16	M14x1,5	33.5	13	11	22	0,04
6840-16-09	8-10	5/16"-3/8"	11/16-16	M16x1,5	33.5	11	12.5	22	0,043
6840-16-11	12	1/2"	13/16-16	M16x1,5	33.5	13	12.5	22	0,058
6840-18-09	8-10	5/16"-3/8"	11/16-16	M18x1,5	34.0	11	14	24	0,045
6840-18-11	12	1/2"	13/16-16	M18x1,5	38.0	13	14	24	0,055
6840-18-13	14-16	5/8"	1-14	M18x1,5	43.0	15.5	14	27	0,12
6840-22-09	8-10	5/16"-3/8"	11/16-16	M22x1,5	36.0	11	15	27	0,052
6840-22-11	12	1/2"	13/16-16	M22x1,5	38.0	13	15	27	0,06
6840-22-13	14-16	5/8"	1-14	M22x1,5	42.0	15.5	15	27	0,127
6840-22-14	18-20	3/4"	1.3/16-12	M22x1,5	48.0	17	15	32	0,17
6840-27-11	12	1/2"	13/16-16	M27x2	44.5	13	18.5	32	0,07
6840-27-14	18-20	3/4"	1.3/16-12	M27x2	48.5	17	18.5	32	0,187
6840-27-15	22-25	1"	1.7/16-12	M27x2	53.0	17.5	18.5	41	0,23
6840-33-14	18-20	3/4"	1.3/16-12	M33x2	48.5	17	18.5	41	0,2
6840-33-15	22-25	1"	1.7/16-12	M33x2	52.0	17.5	18.5	41	0,27
6840-33-21	28-32	1.1/4"	1.11/16-12	M33x2	52.0	17.5	18.5	46	0,37
6840-42-21	28-32	1.1/4"	1.11/16-12	M42x2	54.5	17.5	19	50	0,39
6840-42-32	35-38	1.1/2"	2-12	M42x2	54.5	17.5	19	55	0,4
6840-48-32	35-38	1.1/2"	2-12	M48x2	57.0	17.5	21.5	55	0,412

**Curva Orientabile 90° M/M
ORFS-METRICO
(ISO 6149)**

SDE

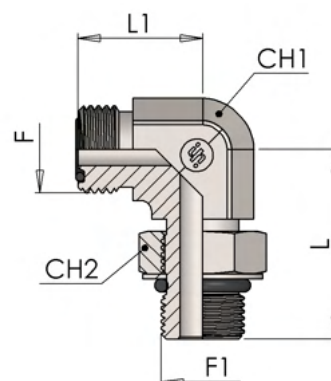

Part number	Dimensions								Weight kg/unit
	Ø		Thread						
	tube mm	tube inch	F	F1	L	L1	CH1	CH2	
6870-10-06	6	1/4"	9/16-18	M10x1	30.0	21	14	14	0.050
6870-12-06	6	1/4"	9/16-18	M12x1.5	33.0	21	14	17	0.052
6870-14-09	8-10	5/16"-3/8"	11/16-16	M14x1.5	36.0	25	19	19	0.060
6870-16-09	8-10	5/16"-3/8"	11-16-16	M16x1.5	38.0	25	19	22	0.065
6870-18-11	12	1/2"	13/16-16	M18x1.5	41.0	28	19	24	0.160
6870-18-13	14-16	5/8"	1-14	M18x1.5	45.5	33.5	27	24	0.190
6870-22-13	14-16	5/8"	1-14	M22x1.5	50.0	33.5	27	27	0.215
6870-27-14	18-20	3/4"	1.3/16-12	M27x2	55.0	37.5	27	32	0.420
6870-33-15	22-25	1"	1.7/16-12	M33x2	59.0	41.5	36	41	0.500
6870-42-21	28-32	1.1/4"	1.11/16-12	M42x2	62.0	44.5	41	50	0.560
6870-48-32	35-38	1.1/2"	2-12	M48x2	68.0	49	50	55	0.685

**Curva Orientabile 45° M/M
ORFS-METRICO
(ISO 6149)**

SDE45

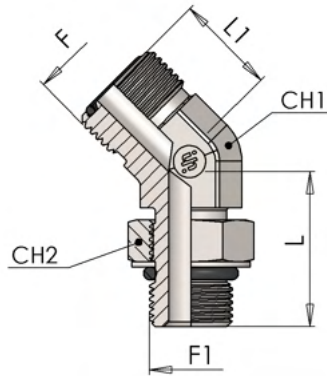

Part number	Dimensions								Weight kg/unit
	Ø		Thread						
	tube mm	tube inch	F	F1	L	L1	CH1	CH2	
6860-12-06	6	1/4"	9/16-18	M12x1.5	30.0	18	14	17	0.045
6860-14-09	8-10	5/16"-3/8"	11/16-16	M14x1.5	32.0	19.5	19	19	0.075
6860-16-09	8-10	5/16"-3/8"	11/16-16	M16x1.5	34.0	19.5	19	22	0.080
6860-18-11	12	1/2"	13/16-16	M18x1.5	37.0	22	19	24	0.110
6860-18-13	14-16	5/8"	1-14	M18x1.5	40.0	26	27	24	0.170
6860-22-13	14-16	5/8"	1-14	M22x1.5	44.0	26	27	27	0.190
6860-27-14	18-20	3/4"	1.3/16-12	M27x2	50.0	27	27	32	0.250
6860-33-15	22-25	1"	1.7/16-12	M33x2	52.5	30	36	41	0.300
6860-42-21	28-32	1.1/4"	1.11/16-12	M42x2	54.0	32	41	50	0.445

Terminale a T orientabile centrale M/M ORFS-METRICO (ISO 6149)

SDBT

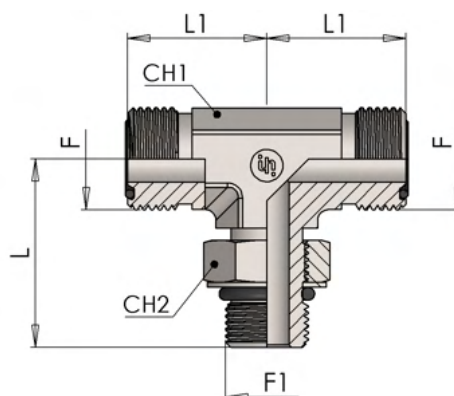

Part number	Dimensions								Weight kg/unit
	Ø		Thread						
	tube mm	tube inch	F	F1	L	L1	CH1	CH2	
6890-12-06	6	1/4"	9/16-18	M12x1.5	33.0	21	14	17	0.066
6890-14-09	8-10	5/16"-3/8"	11/16-16	M14x1.5	36.0	25	19	19	0.080
6890-16-09	8-10	5/16"-3/8"	11/16-16	M16x1.5	38.0	25	19	22	0.085
6890-18-11	12	1/2"	13/16-16	M18x1.5	41.0	28	19	24	0.200
6890-22-13	14-16	5/8"	1-14	M22x1.5	50.0	33.5	27	27	0.280
6890-27-14	18-20	3/4"	1.3/16-12	M27x2	55.0	37.5	27	32	0.530
6890-33-15	22-25	1"	1.7/16-12	M33x2	59.0	41.5	36	41	0.650
6890-42-21	28-32	1.1/4"	1.11/16-12	M42x2	62.0	44.5	41	50	0.730
6890-48-32	35-38	1.1/2"	2-12	M48x2	68.0	49	50	55	0.890

Terminale a T orientabile laterale M/M ORFS-METRICO (ISO 6149)

SDRT

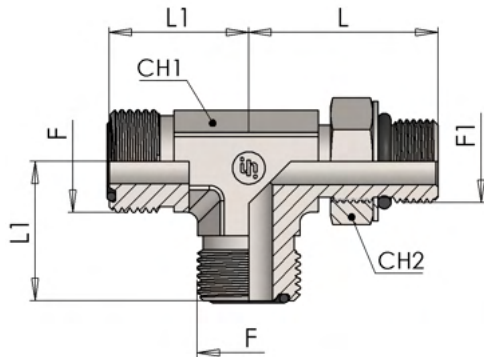

Part number	Dimensions								Weight kg/unit
	Ø		Thread						
	tube mm	tube inch	F	F1	L	L1	CH1	CH2	
6880-12-06	6	1/4"	9/16-18	M12x1.5	33.0	21	14	17	0.066
6880-14-09	8-10	5/16"-3/8"	11/16-16	M14x1.5	36.0	25	19	19	0.080
6880-16-09	8-10	5/16"-3/8"	11/16-16	M16x1.5	38.0	25	19	22	0.085
6880-18-11	12	1/2"	13/16-16	M18x1.5	41.0	28	19	24	0.200
6880-22-13	14-16	5/8"	1-14	M22x1.5	50.0	33.5	27	27	0.280
6880-27-14	18-20	3/4"	1.3/16-12	M27x2	55.0	37.5	27	32	0.530
6880-33-15	22-25	1"	1.7/16-12	M33x2	59.0	41.5	36	41	0.650
6880-42-21	28-32	1.1/4"	1.11/16-12	M42x2	62.0	44.5	41	50	0.730
6880-48-32	35-38	1.1/2"	2-12	M48x2	68.0	49	50	55	0.890

Terminale dritto M/M ORFS-METRICO (Form E ISO 9974-2)

SDS

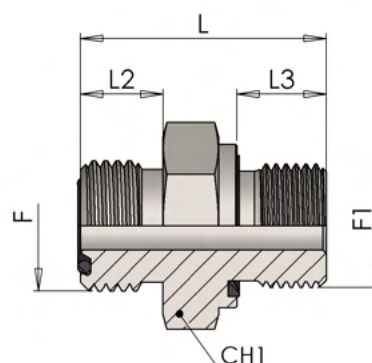

Part number	Dimensions								Weight kg/unit
	Ø		Thread						
	tube mm	tube inch	F	F1	L	L2	L3	CH1	
6905-10-06	6	1/4"	9/16-18	M10x1	25.0	10	8	17	0.020
6905-12-06	6	1/4"	9/16-18	M12x1.5	29.0	10	12	17	0.024
6905-12-09	8-10	5/16"-3/8"	11/16-16	M12x1.5	31.5	11	12	19	0.040
6905-14-06	6	1/4"	9/16-18	M14x1.5	30.5	10	12	19	0.030
6905-14-09	8-10	5/16"-3/8"	11/16-16	M14x1.5	31.5	11	12	19	0.043
6905-16-09	8-10	5/16"-3/8"	11/16-16	M16x1.5	31.5	11	12	22	0.043
6905-16-11	12	1/2"	13/16-16	M16x1.5	33.5	13	12	22	0.058
6905-18-11	12	1/2"	13/16-16	M18x1.5	33.5	13	12	24	0.050
6905-18-13	14-16	5/8"	1-14	M18x1.5	37.5	15.5	12	27	0.120
6905-22-13	14-16	5/8"	1-14	M22x1.5	39.5	15.5	14	27	0.127
6905-27-14	18-20	3/4"	1.3/16-12	M27x2	45.0	17	16	32	0.187
6905-33-15	22-25	1"	1.7/16-12	M33x2	48.0	17.5	18	41	0.270
6905-42-21	28-32	1.1/4"	1.11/16-12	M42x2	51.5	17.5	20	50	0.390
6905-48-32	35-38	1.1/2"	2-12	M48x2	55.5	17.5	22	55	0.412

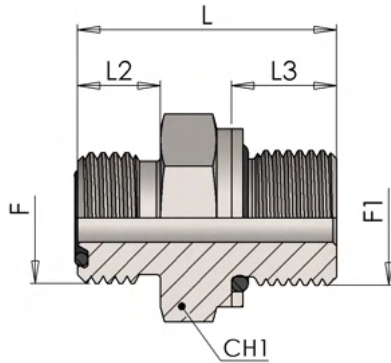

Terminale dritto M/M ORFS-METRICO con o-ring ed anello

SDS

Part number	Dimensions								Weight kg/unit
	Ø		Thread						
	tube mm	tube inch	F	F1	L	L2	L3	CH1	
6900-10-06	6	1/4"	9/16-18	M10x1	26.0	10	9	17	0,02
6900-12-06	6	1/4"	9/16-18	M12x1,5	28.5	10	11.5	17	0,024
6900-14-09	8-10	5/16"-3/8"	11/16-16	M14x1,5	30.5	11	11.5	19	0,043
6900-16-09	8-10	5/16"-3/8"	11/16-16	M16x1,5	33.0	11	13	22	0,043
6900-18-11	12	1/2"	13/16-16	M18x1,5	36.0	13	13.5	24	0,055
6900-22-13	14-16	5/8"	1-14	M22x1,5	40.5	15.5	15	27	0,127
6900-27-14	18-20	3/4"	1.3/16-12	M27x2	47.5	17	18.5	32	0,187
6900-33-15	22-25	1"	1.7/16-12	M33x2	50.0	17.5	18.5	41	0,27
6900-42-21	28-32	1.1/4"	1.11/16-12	M42x2	52.5	17.5	19	50	0,39
6900-48-32	35-38	1.1/2"	2-12	M48x2	55.0	17.5	21.5	55	0,412

**Curva Orientabile 90° M/M
ORFS-METRICO
con o-ring ed anello**

SDE

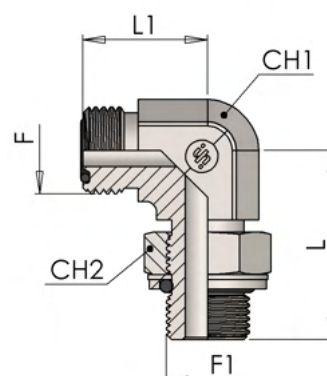

Part number	Dimensions								Weight kg/unit
	Ø		Thread						
	tube mm	tube inch	F	F1	L	L1	CH1	CH2	
6320-10-06	6	1/4"	9/16-18	M10X1	30.0	21	14	14	0,038
6320-12-06	6	1/4"	9/16-18	M12X1.5	33.0	21	14	17	0,044
6320-14-09	8-10	5/16"-3/8"	11/16-16	M14X1.5	36.0	25	19	19	0,075
6320-16-09	8-10	5/16"-3/8"	11/16-16	M16X1.5	38.0	25	19	22	0,082
6320-16-11	12	1/2"	13/16-16	M16X1.5	38.0	28	19	22	0,1
6320-18-11	12	1/2"	13/16-16	M18X1.5	41.0	28	19	24	0,11
6320-18-13	14-16	5/8"	1-14	M18X1.5	45.5	33.5	27	24	0,16
6320-22-13	14-16	5/8"	1-14	M22X1.5	50.0	33.5	27	27	0,19
6320-22-14	18-20	3/4"	1.3/16-12	M22X1.5	50.0	37.5	27	27	0,205
6320-27-14	18-20	3/4"	1.3/16-12	M27X2	55.0	37.5	27	32	0,235
6320-27-15	22-25	1"	1.7/16-12	M27X2	57.0	41.5	36	32	0,27
6320-33-15	22-25	1"	1.7/16-12	M33X2	59.0	41.5	36	41	0,3
6320-42-21	28-32	1.1/4"	1.11/16-12	M42X2	62.0	44.5	41	50	0,445
6320-48-32	35-38	1.1/2"	2-12	M48X2	68.0	49	50	55	0,57

6270

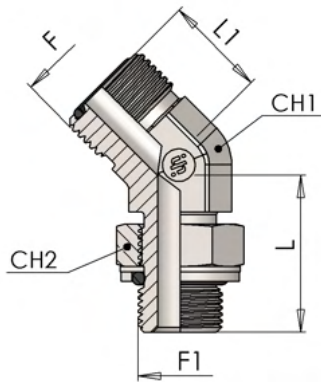

**Curva Orientabile 45° M/M
ORFS-METRICO
con o-ring ed anello**

SDE45

Part number	Dimensions								Weight kg/unit
	Ø		Thread		L	L1	CH1	CH2	
	tube mm	tube inch	F	F1					
6270-10-06	6	1/4"	9/16-18	M10X1	28.0	18	14	14	0,038
6270-12-06	6	1/4"	9/16-18	M12X1.5	30.0	18	14	17	0,044
6270-14-09	8-10	5/16"-3/8"	11/16-16	M14X1.5	32.0	19.5	19	19	0,075
6270-16-09	8-10	5/16"-3/8"	11/16-16	M16X1.5	34.0	19.5	19	22	0,082
6270-18-11	12	1/2"	13/16-16	M18X1.5	37.0	22	19	24	0,11
6270-18-13	14-16	5/8"	1-14	M18X1.5	40.0	26	27	24	0,16
6270-22-13	14-16	5/8"	1-14	M22X1.5	44.0	26	27	27	0,19
6270-27-14	18-20	3/4"	1.3/16-12	M27X2	50.0	27	27	32	0,235
6270-33-15	22-25	1"	1.7/16-12	M33X2	52.5	30	36	41	0,3
6270-42-21	28-32	1.1/4"	1.11/16-12	M42X2	54.0	32	41	50	0,445

Terminale a T orientabile centrale M/M ORFS-METRICO con o-ring ed anello

SDBT

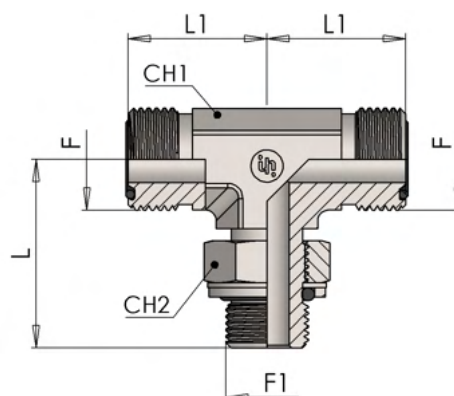

Part number	Dimensions								Weight kg/unit
	Ø		Thread						
	tube mm	tube inch	F	F1	L	L1	CH1	CH2	
6420-12-06	6	1/4"	9/16-18	M12X1.5	33.0	21	14	17	0,066
6420-14-09	8-10	5/16"-3/8"	11/16-16	M14X1.5	36.0	25	19	19	0,097
6420-16-09	8-10	5/16"-3/8"	11/16-16	M16X1.5	38.0	25	19	22	0,131
6420-18-11	12	1/2"	13/16-16	M18X1.5	41.0	28	19	24	0,187
6420-22-13	14-16	5/8"	1-14	M22X1.5	50.0	33.5	27	27	0,283
6420-27-14	18-20	3/4"	1.3/16-12	M27X2	55.0	37.5	27	32	0,549
6420-33-15	22-25	1"	1.7/16-12	M33X2	59.0	41.5	36	41	0,565
6420-42-21	28-32	1.1/4"	1.11/16-12	M42X2	62.0	44.5	41	50	0,824
6420-48-32	35-38	1.1/2"	2-12	M48X2	68.0	49	50	55	0,94

Terminale a T orientabile laterale M/M ORFS-METRICO con o-ring ed anello

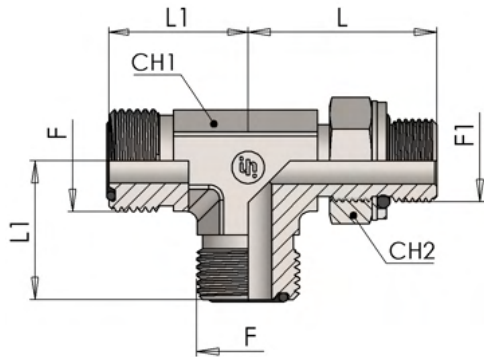

SDRT

Part number	Dimensions								Weight kg/unit
	Ø		Thread						
	tube mm	tube inch	F	F1	L	L1	CH1	CH2	
6470-12-06	6	1/4"	9/16-18	M12X1.5	33.0	21	14	17	0,066
6470-14-09	8-10	5/16"-3/8"	11/16-16	M14X1.5	36.0	25	19	19	0,097
6470-16-09	8-10	5/16"-3/8"	11/16-16	M16X1.5	38.0	25	19	22	0,131
6470-18-11	12	1/2"	13/16-16	M18X1.5	41.0	28	19	24	0,2
6470-22-13	14-16	5/8"	1-14	M22X1.5	50.0	33.5	27	27	0,283
6470-27-14	18-20	3/4"	1.3/16-12	M27X2	55.0	37.5	27	32	0,549
6470-33-15	22-25	1"	1.7/16-12	M33X2	59.0	41.5	36	41	0,652
6470-42-21	28-32	1.1/4"	1.11/16-12	M42X2	62.0	44.5	41	50	0,824
6470-48-32	35-38	1.1/2"	2-12	M48X2	68.0	49	50	55	0,94

Terminale dritto M/M ORFS-NPT

SDS

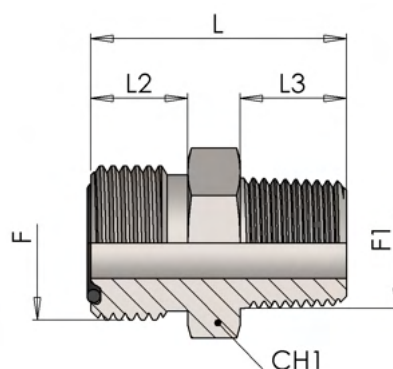

Part number	Dimensions								Weight kg/unit
	Ø		Thread						
	tube mm	tube inch	F	F1	L	L2	L3	CH1	
6830-02-06	6	1/4"	9/16-18	1/8-27 NPT	27.0	10	10	17	0,026
6830-04-06	6	1/4"	9/16-18	1/4-18 NPT	33.0	10	14.5	17	0,034
6830-04-09	8-10	5/16"-3/8"	11/16-16	1/4-18 NPT	34.0	11	14.5	19	0,039
6830-06-06	6	1/4"	9/16-18	3/8-18 NPT	33.0	10	14.5	19	0,047
6830-06-09	8-10	5/16"-3/8"	11/16-16	3/8-18 NPT	34.0	11	14.5	19	0,052
6830-06-11	12	1/2"	13/16-16	3/8-18 NPT	37.0	13	14.5	22	0,083
6830-08-09	8-10	5/16"-3/8"	11/16-16	1/2-14 NPT	35.0	11	19	22	0,082
6830-08-11	12	1/2"	13/16-16	1/2-14 NPT	42.0	13	19	22	0,084
6830-08-13	14-16	5/8"	1-14	1/2-14 NPT	44.5	15.5	19	27	0,115
6830-08-14	18-20	3/4"	1.3/16-12	1/2-14 NPT	48.0	17	19	32	0,165
6830-12-11	8-10	5/16"-3/8"	13/16-16	3/4-14 NPT	45.0	13	19	27	0,166
6830-12-13	14-16	5/8"	1-14	3/4-14 NPT	46.5	15.5	19	27	0,138
6830-12-14	18-20	3/4"	1.3/16-12	3/4-14 NPT	48.0	17	19	32	0,179
6830-12-15	22-25	1"	1.7/16-12	3/4-14 NPT	49.0	17.5	19	41	0,238
6830-16-14	18-20	3/4"	1.3/16-12	1-11.1/2 NPT	53.5	17	24	36	0,225
6830-16-15	22-25	1"	1.7/16-12	1-11.1/2 NPT	54.0	17.5	24	41	0,271
6830-20-21	28-32	1.1/4"	1.11/16-12	1.1/4-1.1/2 NPT	56.0	17.5	24.5	46	0,424
6830-24-32	35-38	1.1/2"	2-12	1.1/2-11.1/2 NPT	59.0	17.5	25.5	55	0,534

Terminale a 90° M/M ORFS-NPT

SDE

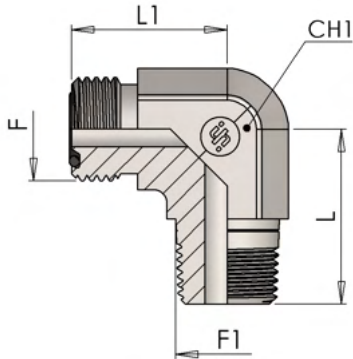

Part number	Dimensions							Weight kg/unit
	Ø		Thread		L	L1	CH1	
	tube mm	tube inch	F	F1				
6230-02-06	6	1/4"	9/16-18	1/8-27 NPT	21.0	21	14	0.040
6230-04-06	6	1/4"	9/16-18	1/4-18 NPT	27.5	21	14	0.050
6230-06-09	8-10	5/16"-3/8"	11/16-16	3/8-18 NPT	31.0	25	19	0.080
6230-06-11	12	1/2"	13/16-16	3/8-18 NPT	31.0	28	19	0.090
6230-08-11	12	1/2"	13/16-16	1/2-14 NPT	37.0	28	22	0.125
6230-08-13	14-16	5/8"	1-14	1/2-14 NPT	36.0	33.5	27	0.155
6230-12-14	18-20	3/4"	1.3/16-12	3/4-14 NPT	40.5	37.5	27	0.205
6230-16-15	22-25	1"	1.7/16-12	1-11.1/2 NPT	50.0	41.5	36	0.385
6230-20-21	28-32	1.1/4"	1.11/16-12	1.1/4-1.1/2 NPT	60.5	44.5	41	0.470
6230-24-32	35-38	1.1/2"	2-12	1.1/2-11.1/2 NPT	67.0	49	50	0.605

Tappo maschio ORFS (ISO 8434-3)

PL

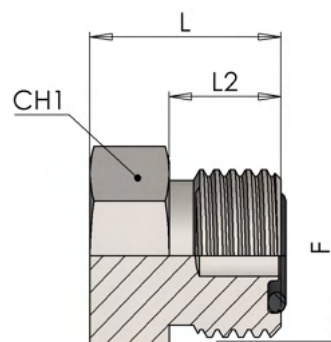

Part number	Dimensions						Weight kg/unit
	Ø		Thread				
	tube mm	tube inch	F	L	L2	CH1	
6600-06	6	1/4"	9/16-18	16.5	10	17	0,018
6600-09	8-10	5/16"-3/8"	11/16-16	19.0	11	19	0,034
6600-11	12	1/2"	13/16-16	22.0	13	22	0,045
6600-13	14-16	5/8"	1-14	26.0	15.5	27	0,091
6600-14	18-20	3/4"	1.3/16-12	27.5	17	32	0,138
6600-15	22-25	1"	1.7/16-12	28.0	17.5	41	0,203
6600-21	28-32	1.1/4"	1.11/16-12	28.0	17.5	46	0,266
6600-32	35-38	1.1/2"	2-12	28.0	17.5	55	0,369

**Tappo femmina girevole ORFS
(ISO 8434-3)**

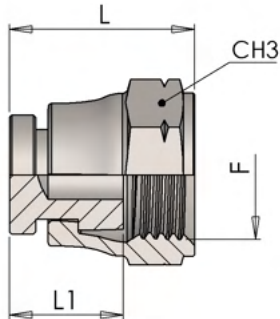

CP

Part number	Dimensions						Weight kg/unit
	Ø		Thread				
	tube mm	tube inch	F	L	L1	CH3	
6610-06	6	1/4"	9/16-18	17.0	9	17	0,0021
6610-09	8-10	5/16"-3/8"	11/16-16	19.0	10.5	22	0,0043
6610-11	12	1/2"	13/16-16	22.0	12	24	0,0055
6610-13	14-16	5/8"	1-14	26.0	13.5	30	0,0105
6610-14	18-20	3/4"	1.3/16-12	28.5	15	36	0,0165
6610-15	22-25	1"	1.7/16-12	29.5	16	41	0,0215
6610-21	30-32	1.1/4"	1.11/16-12	29.5	16	50	0,0325
6610-32	35-38	1.1/2"	2-12	29.5	16	60	0,0455

Terminale dritto maschio ORFS a saldare con tasca (ISO 8434-3)

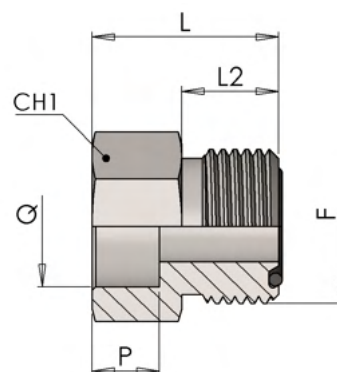
BRS

Part number	Dimensions								Weight kg/unit
	Ø		Thread						
	tube mm	tube inch	F	Q	P	L	L2	CH1	
MO-06-10	6	1/4"	9/16-18	10	8.5	22.0	10	17	0.023
MO-09-10	8-10	5/16"-3/8"	11/16-16	10	8.5	23.0	11	19	0.036
MO-09-12	8-10	5/16"-3/8"	11/16-16	12	8.5	23.0	11	19	0.030
MO-11-12	12	1/2"	13/16-16	12	8.5	24.5	13	22	0.044
MO-11-16	12	1/2"	13/16-16	16	9	25.0	13	22	0.042
MO-13-16	14-16	5/8"	1-14	16	9	28.0	15.5	27	0.104
MO-14-20	18-20	3/4"	1.3/16-12	20	12.5	33.5	17	32	0.144
MO-14-25	18-20	3/4"	1.3/16-12	25	14	35.0	17	32	0.220
MO-15-25	22-25	1"	1.7/16-12	25	14	38.5	17.5	41	0.225
MO-15-30	22-25	1"	1.7/16-12	30	14	38.5	17.5	41	0.276
MO-21-32	28-32	1.1/4"	1.11/16-12	32	14	38.5	17.5	46	0.278
MO-21-38	28-32	1.1/4"	1.11/16-12	38	14	38.5	17.5	50	0.371

Indice

6010	pag 6
6015	pag 7
6000.....	pag 8
6300	pag 9
6350	pag 10
6550	pag 11
6120	pag 12
6036	pag 13
6850	pag 14
6060	pag 15
6056	pag 16
6205	pag 17
6255	pag 18
6620	pag 19
6630	pag 20
6050	pag 21
6510	pag 22
0107	pag 23
6150	pag 24
6100	pag 25
6200	pag 26
6250	pag 27
6400	pag 28
6450	pag 29
6850	pag 30
6800	pag 31
6215	pag 32
6260	pag 33
6460	pag 34
6410	pag 35
6840	pag 36
6870	pag 37
6860	pag 38
6890	pag 39
6880	pag 40

Indice

6905	pag 41
6900	pag 42
6320	pag 43
6270	pag 44
6420	pag 45
6470	pag 46
6830	pag 47
6230	pag 48
6600	pag 49
6610	pag 50
MO	pag 51

JIC

in!



5000



Nut

6



5010



Metric Sleeve

7



1900

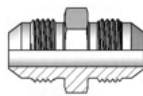

Union

8

5100

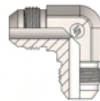

90° Elbow Union

9

5120



Union Tee

10

5900

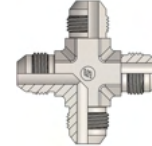

Union Cross

11



5050

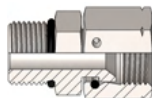

Swivel Connector
M UNF x F JIC

12

5036

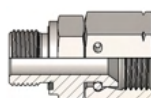

Swivel Connector
F JIC x M BSP OR (ED)

13

5035

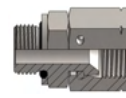

Swivel connector
M BSP x F JIC

14

5037

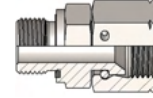

Swivel Connector
F JIC x M Metric OR (ED)

15

5038

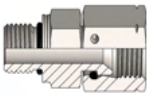

Swivel Connector
M Metric x F JIC

16

5045

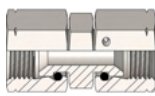

Swivel Union

17

5056

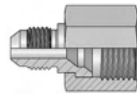

Swivel Reduction
M JIC x F JIC

18

5060

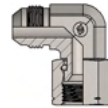

90° Swivel Elbow
F JIC x M JIC

19

5070



45° Swivel Elbow
F JIC x M JIC

20

5080



Run Tee Swivel
Connector

21

5090

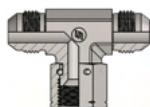

Branch Tee Swivel
Connector

22



5110

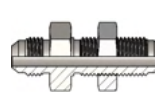

Bulkhead Union

23

5130

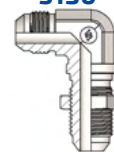

90° Bulkhead
Elbow Union

24

J107



Bulkhead

25



1906

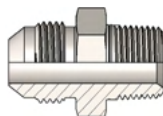

Male Connector

26

5140

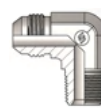

90° Elbow Connector

27

5150



45° Elbow Connector

28

5160

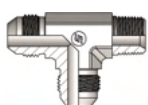

Run Tee Connector

29

5170

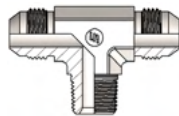

Branch Tee Connector

30

5180

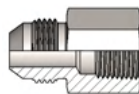

Male-Female Connector

31



1907

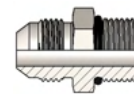

Male Connector

32

5190

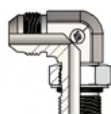

90° Elbow Connector

33

5200



45° Elbow Connector

34

5210

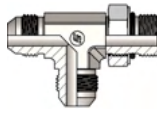

Run Tee Connector

35

5220

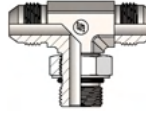

Branch Tee Connector

36



5805

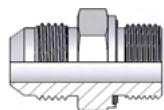

Male Connector
M JIC x M BSP OR (ED)

37

1915

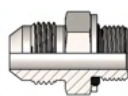

Male Connector
M JIC x M BSP

38

1905

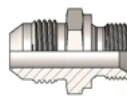

Male Connector
M JIC x M BSP

39

5185

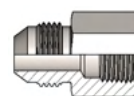

Male-Female Connector

40

5230

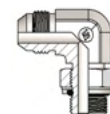

90° Elbow Connector

41

5235



Adjustable 45° Elbow

42

5240

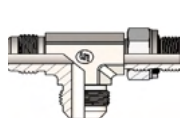

Run Tee Connector

43

5250

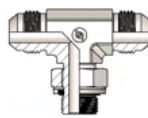

Branch Tee Connector

44



1910

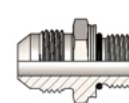

Male Connector
M Metric x M JIC

45

5430

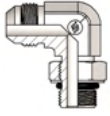

90° Adjustable Stud Elbow

46

5440



45° Adjustable Stud Elbow

47

5450

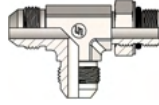

Adjustable Stud Run Tee

48

5455

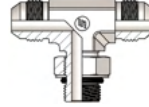

Adjustable Stud Branch Tee

49

1775

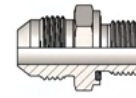

Male Connector M Metric x M JIC OR (ED)

50

1777

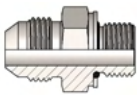

Male Connector M Metric x M JIC

51

5400

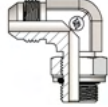

Adjustable Elbow c

52

5410



Adjustable 45° Elbow

53

5420

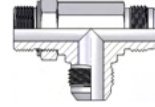

Adjustable Run Tee

54

5425

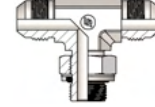

Adjustable Branch Tee

55



1903

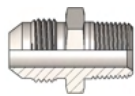

Male Connector

56

5165



90° Elbow Connector

57

5265



45° Elbow Connector

58

5275

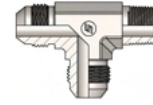

Run Tee Connector

59

5280

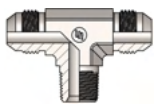

Branch Tee Connector

60



5040

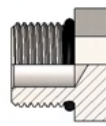

SAE Plug

61

J605

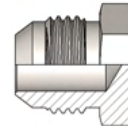

JIC Male Plug

62

J608

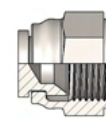

JIC Female Plug

63

MJ

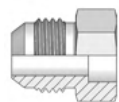

Braze-On Straight Connector

64

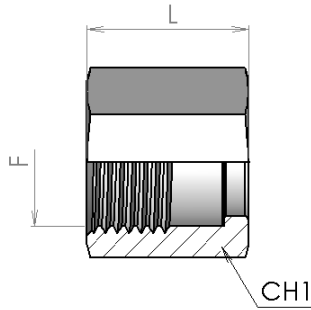

Part number	Dimensions				Weight kg/unit
	Ø		L	CH1	
	tube mm	tube inch			
5000-04	6	1/4"	15.8	14	0,011
5000-05	8	5/16"	17.3	17	0,014
5000-06	10	3/8"	18.5	19	0,018
5000-08	12	1/2"	21.6	22	0,029
5000-10	16	5/8"	24.9	27	0,042
5000-12	20	-	26.2	32	0,070
5000-16	25	1"	28.7	41	0,105
5000-20	32	1-1/4"	31.2	50	0,240
5000-24	38	1-1/2"	36.1	60	0,320

Bussola per tubo metrico (ISO 8434-2)

MSL

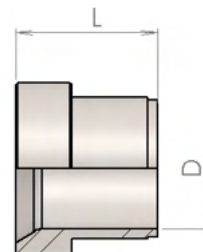

Part number	Dimensions			Weight kg/unit
	Ø tube mm	D	L	
5010-06	6	6	10.5	0,002
5010-08	8	8	11.5	0,002
5010-10	10	10	12.5	0,002
5010-12	12	12	14.5	0,007
5010-14	14	14	16.5	0,013
5010-16	16	16	16.5	0,015
5010-18	18	18	17	0,016
5010-20	20	20	17	0,012
5010-25	25	25	19.5	0,021
5010-30	30	30	23	0,045
5010-32	32	32	23	0,030
5010-38	38	38	28.5	0,050

Unione diretto maschio JIC (ISO 8434-2)

S

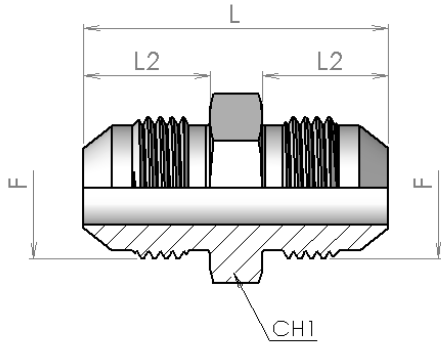

Part number	Dimensions						Weight kg/unit
	Ø		F	L	L2	CH1	
	tube mm	tube inch					
1900-04-04	6	1/4"	7/16-20	35	14	12	0,016
1900-05-05	8	5/16"	1/2-20	35	14	14	0,018
1900-06-06	10	3/8"	9/16-18	36	14	17	0,025
1900-08-08	12	1/2"	3/4-16	41	17	22	0,052
1900-10-10	16	5/8"	7/8-14	48	19	24	0,08
1900-12-12	20	3/4"	1 1/16-12	55	22	30	0,125
1900-16-16	25	1"	1 5/16-12	57	23	36	0,13
1900-20-20	30-32	1.1/4"	1 5/8-12	61.5	24	46	0,27
1900-24-24	38	1.1/2"	1 7/8-12	70	27.5	50	0,385
1900-32-32	50	2"	2 1/2-12	86.5	34	65	0,78

Unione a 90° maschio JIC (ISO 8434-2)

E

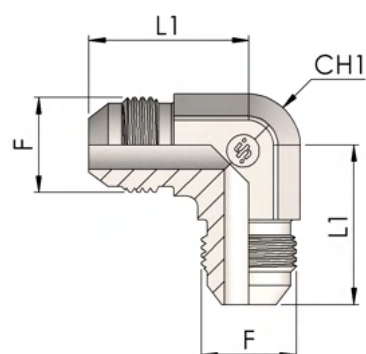

Part number	Dimensions					Weight kg/unit
	Ø		F	L1	CH1	
	tube mm	tube inch				
5100-04	6	1/4"	7/16-20	22.5	12	0,025
5100-05	8	5/16"	1/2-20	24	14	0,03
5100-06	10	3/8"	9/16-18	27	14	0,045
5100-08	12	1/2"	3/4-16	32	19	0,09
5100-10	16	5/8"	7/8-14	37	22	0,14
5100-12	20	3/4"	1 1/16-12	42	27	0,26
5100-16	25	1"	1 5/16-12	46	33	0,33
5100-20	32	1.1/4"	1 5/8-12	52.5	41	0,585
5100-24	38	1.1/2"	1 7/8-12	59	50	0,8

Unione a T maschio JIC (ISO 8434-2)

T

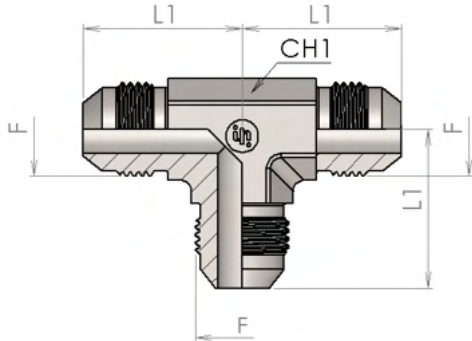

Part number	Dimensions						Weight kg/unit
	Ø		F	L	L1	CH1	
	tube mm	tube inch					
5120-04	6	1/4"	7/16-20	52	22	12	0,035
5120-05	8	5/16"	1/2-20	48	24	14	0,045
5120-06	10	3/8"	9/16-18	52	27	14	0,055
5120-08	12	1/2"	3/4-16	64	32	19	0,12
5120-10	16	5/8"	7/8-14	64	36	22	0,18
5120-12	20	3/4"	1 1/16-12	84	42	27	0,29
5120-16	25	1"	1 5/16-12	92	46	33	0,415
5120-20	32	1.1/4"	1 5/8-12	104	52	41	0,7
5120-24	38	1.1/2"	1 7/8-12	118	59	50	1

Unione a croce maschio JIC (ISO 8434-2)

K

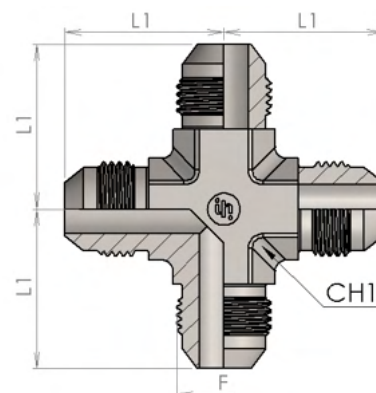

Part number	Dimensions					Weight kg/unit
	Ø		F	L	CH1	
	tube mm	tube inch				
5900-04	6	1/4"	7/16-20	23	14	0,045
5900-05	8	5/16"	1/2-20	24	14	0,05
5900-06	10	3/8"	9/16-18	27	14	0,065
5900-08	12	1/2"	3/4-16	32	19	0,145
5900-10	16	5/8"	7/8-14	37	22	0,22
5900-12	20	3/4"	1 1/16-12	42	27	0,34

5050

Terminale dritto F/M JIC-UNF (ISO 11926)

SWS

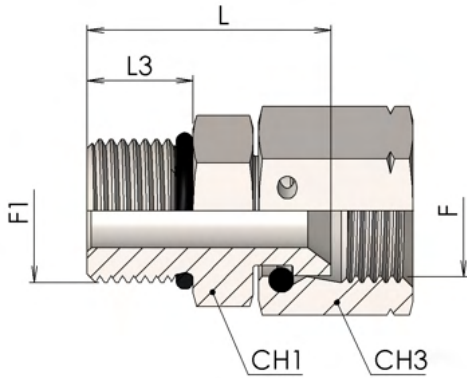

Part number	Dimensions								Weight kg/unit
	Ø		F	F1	L	L3	CH1	CH3	
	tube mm	tube inch							
5050-04	6	1/4"	7/16-20	7/16-20	27	9	14	14	0,03
5050-05	8	5/16"	1/2-20	1/2-20	28	9	17	17	0,033
5050-06	10	3/8"	9/16-18	9/16-18	32	10	17	19	0,038
5050-08	12	1/2"	3/4-16	3/4-16	33	11	22	22	0,065
5050-10	16	5/8"	7/8-14	7/8-14	36.5	12.5	27	27	0,115
5050-12	20	3/4"	1 1/16-12	1 1/16-12	41	15	32	32	0,185
5050-16	25	1"	1 5/16-12	1 5/16-12	43.5	15	41	41	0,235
5050-20	32	1.1/4"	1 5/8-12	1 5/8-12	47	15	50	60	0,5
5050-24	38	1.1/2"	1 7/8-12	1 7/8-12	51.5	15	55	60	0,69

**Terminale dritto F/M
JIC-BSP
(Form E ISO 1179-2)**

SWS

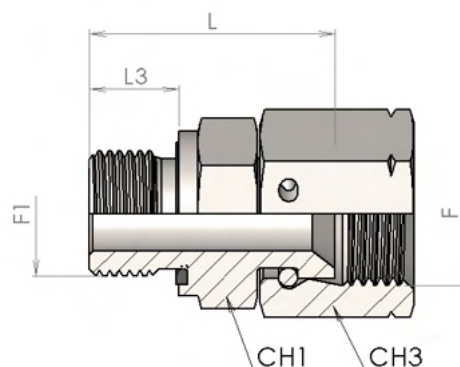

Part number	Dimensions									Weight kg/unit
	Ø		F	F1	D	L	L3	CH1	CH3	
	tube mm	tube inch								
5036-02-04	6	1/4"	7/16-20	G 1/8	26	25	8	14	14	0,03
5036-04-04	6	1/4"	7/16-20	G 1/4	26	30.5	12	19	14	0,04
5036-04-05	8	5/16"	1/2-20	G 1/4	27	31.5	12	19	17	0,042
5036-04-06	10	3/8"	9/16-18	G 1/4	28	32.5	12	19	19	0,045
5036-06-06	10	3/8"	9/16-18	G 3/8	30	34.5	12	22	19	0,06
5036-06-08	12	1/2"	3/4-16	G 3/8	32	33	12	22	22	0,065
5036-06-10	14-16	5/8"	7/8-14	G 3/8	36	34	12	24	27	0,085
5036-08-08	12	1/2"	3/4-16	G 1/2	34	36.5	14	27	22	0,098
5036-08-10	14-16	5/8"	7/8-14	G 1/2	38	37	14	27	27	0,125
5036-12-12	18-20	3/4"	1 1/16-12	G 3/4	39	41	16	32	32	0,27
5036-12-16	25	1"	1 5/16-12	G 3/4	43	42.5	16	36	41	0,32
5036-16-16	25	1"	1 5/16-12	G 1	44	45	18	41	41	0,4
5036-20-20	30-32	1.1/4"	1 5/8-12	G 1.1/4	47	55	20	50	50	0,58
5036-24-24	38	1.1/2"	1 7/8-12	G 1.1/2	55	57	22	55	60	0,79

5035

Terminale dritto F/M JIC-BSP (ISO 1179)

SWS

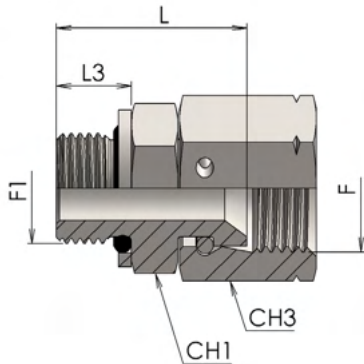

Part number	Dimensions								Weight kg/unit
	Ø		F	F1	L	L3	CH1	CH3	
	tube mm	tube inch							
5035-04-02	6	1/4"	7/16-20	G 1/8	25	8	14	14	0,03
5035-04-04	6	1/4"	7/16-20	G 1/4	30.5	12	19	14	0,039
5035-04-06	6	1/4"	7/16-20	G 3/8	31.5	12	22	14	0,057
5035-05-04	8	5/16"	1/2-20	G 1/4	31.5	12	19	17	0,042
5035-05-06	8	5/16"	1/2-20	G 3/8	31.5	12	22	17	0,057
5035-06-04	10	3/8"	9/16-18	G 1/4	32.5	12	19	19	0,046
5035-06-06	10	3/8"	9/16-18	G 3/8	32.5	12	22	19	0,061
5035-06-08	10	3/8"	9/16-18	G 1/2	34.5	14	27	19	0,089
5035-08-04	12	1/2"	3/4-16	G 1/4	33	12	19	22	0,055
5035-08-06	12	1/2"	3/4-16	G 3/8	33	12	22	22	0,062
5035-08-08	12	1/2"	3/4-16	G 1/2	36.5	14	27	22	0,098
5035-10-06	16	5/8"	7/8-14	G 3/8	34	12	24	27	0,084
5035-10-08	16	5/8"	7/8-14	G 1/2	37	14	27	27	0,127
5035-10-12	16	5/8"	7/8-14	G 3/4	41	16	36	27	0,25
5035-12-08	20	3/4"	1 1/16-12	G 1/2	37	14	27	32	0,15
5035-12-12	20	3/4"	1 1/16-12	G 3/4	41	16	36	32	0,27
5035-12-16	20	3/4"	1 1/16-12	G 1	43.5	18	41	41	0,36
5035-16-12	25	1"	1 5/16-12	G 3/4	42.5	16	36	41	0,32
5035-16-16	25	1"	1 5/16-12	G 1	45	18	41	41	0,4
5035-20-20	30	0	1 5/8-12	G 1.1/4	55	20	50	50	0,58
5035-24-24	38	1.1/2"	1 7/8-12	G 1.1/2	57	22	55	60	0,79

**Terminale dritto F/M
JIC-METRICO
(Form E ISO 9974-2)**

SWS

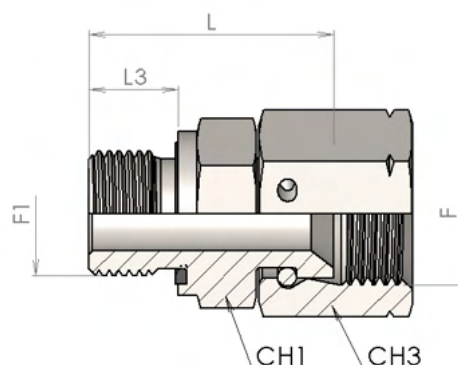

Part number	Dimensions									Weight kg/unit
	Ø		F	F1	D	L	L3	CH1	CH3	
	tube mm	tube inch								
5037-10-04	6	1/4"	7/16-20	M10x1	24.5	25	8	14	14	0,028
5037-12-05	8	5/16"	1/2-20	M12x1,5	26	30	12	17	17	0,032
5037-14-06	10	3/8"	9/16-18	M14x1,5	26.8	32	12	19	19	0,042
5037-16-08	12	1/2"	3/4-16	M16x1,5	29.6	32.5	12	22	22	0,062
5037-18-08	12	1/2"	3/4-16	M18x1,5	30.6	33.5	12	24	22	0,07
5037-18-10	14-16	5/8"	7/8-14	M18x1,5	34.6	34	12	24	27	0,125
5037-22-10	14-16	5/8"	7/8-14	M22x1,5	36.1	37	14	27	27	0,155
5037-22-12	18-20	3/4"	1 1/16-12	M22x1,5	36.2	38	14	27	32	0,16
5037-27-12	18-20	3/4"	1 1/16-12	M27x2	36.7	41	16	32	32	0,175
5037-33-16	25	1"	1 5/16-12	M33x2	41.4	43	18	41	41	0,26
5037-42-20	30-32	1.1/4"	1 5/8-12	M42x2	43.8	50.5	20	50	50	0,485

5038

Terminale dritto F/M JIC-METRICO (ISO 6149)

SWS

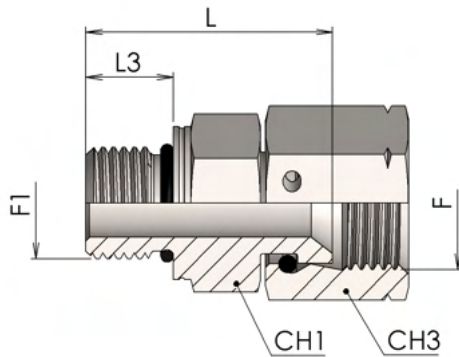

Part number	Dimensions								Weight kg/unit
	Ø		F	F1	L	L3	CH1	CH3	
	tube mm	tube inch							
5038-10-04	6	1/4"	7/16-20	M10x1	26.5	9.5	14	14	0,025
5038-10-05	8	5/16"	1/2-20	M10x1	27.5	9.5	14	14	0,04
5038-12-04	6	1/4"	7/16-20	M12x1,5	28	11	17	14	0,03
5038-12-05	8	5/16"	1/2-20	M12x1,5	29	11	17	17	0,065
5038-14-06	10	3/8"	9/16-18	M14x1,5	31	11	19	19	0,07
5038-16-06	10	3/8"	9/16-18	M16x1,5	32.5	12.5	22	19	0,08
5038-16-08	12	1/2"	3/4-16	M16x1,5	33	12.5	22	22	0,085
5038-18-08	12	1/2"	3/4-16	M18x1,5	35.5	14	24	22	0,095
5038-18-10	14-16	5/8"	7/8-14	M18x1,5	36	14	24	27	0,11
5038-22-10	14-16	5/8"	7/8-14	M22x1,5	38	15	27	27	0,12
5038-22-12	18-20	3/4"	1 1/16-12	M22x1,5	39	15	27	32	0,185
5038-27-12	18-20	3/4"	1 1/16-12	M27x2	43.5	18.5	32	32	0,2
5038-27-16	25	1"	1 5/16-12	M27x2	45	18.5	32	41	0,23
5038-33-16	25	1"	1 5/16-12	M33x2	45.5	18.5	41	41	0,25
5038-42-20	30-32	1.1/4"	1 5/8-12	M42x2	49.5	19	50	50	0,5
5038-48-24	38	1.1/2"	1 7/8-12	M48x2	54.5	21.5	55	60	0,69

Unione diritto girevole
JIC
(ISO 8434-2)

SWS

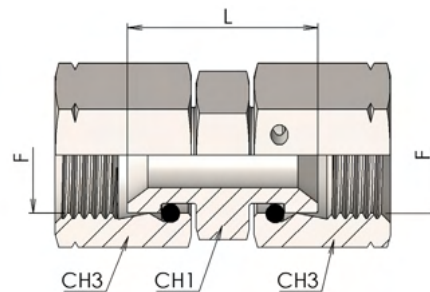

Part number	Dimensions						Weight kg/unit
	Ø		F	L	CH1	CH3	
	tube mm	tube inch					
5045-06	10	3/8"	9/16-18	26	19	19	0,04
5045-08	12	1/2"	3/4-16	29.5	22	22	0,07
5045-10	14-16	5/8"	7/8-14	31.5	27	27	0,12
5045-12	18-20	3/4"	1 1/16-12	33.5	32	32	0,19
5045-16	25	1"	1 5/16-12	38	41	41	0,245

Terminale dritto di riduzione F/M JIC

SRDS

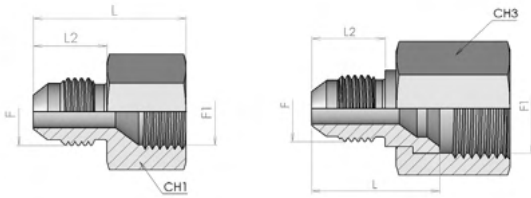

Part number	Dimensions								Weight kg/unit
	Ø								
	tube mm	tube inch	F	F1	L	L2	CH1	CH3	
5056-06-04	6	1/4"	7/16-20	9/16-18	24.5	14		19	0,032
5056-06-05	8	5/16"	1/2-20	9/16-18	26	14	19		0,03
5056-08-04	6	1/4"	7/16-20	3/4-16	27.5	14		22	0,038
5056-08-05	8	5/16"	1/2-20	3/4-16	27.5	14		22	0,035
5056-08-06	10	3/8"	9/16-18	3/4-16	27.5	14		22	0,032
5056-10-04	6	1/4"	7/16-20	7/8-14	27.5	14		27	0,083
5056-10-06	10	3/8"	9/16-18	7/8-14	27.5	14		27	0,078
5056-10-08	12	1/2"	3/4-16	7/8-14	37	16.7	27		0,075
5056-12-04	6	1/4"	7/16-20	1 1/16-12	31	14		32	0,12
5056-12-06	10	3/8"	9/16-18	1 1/16-12	31	14		32	0,115
5056-12-08	12	1/2"	3/4-16	1 1/16-12	33.5	16.7		32	0,128
5056-12-10	14-16	5/8"	7/8-14	1 1/16-12	36	19.3	32		0,12
5056-16-10	14-16	5/8"	7/8-14	1 5/16-12	35	19.3		41	0,24
5056-16-12	18-20	3/4"	1 1/16-12	1 5/16-12	35	22		41	0,25
5056-20-12	18-20	3/4"	1 1/16-12	1 5/8-12	41	22		50	0,37
5056-20-16	25	1"	1 5/16-12	1 5/8-12	42	23		50	0,355
5056-24-20	30-32	1.1/4"	1 5/8-12	1 7/8-12	43	24.5		60	0,615

Girevole a 90° F/M
JIC
(ISO 8434-2)

SWE

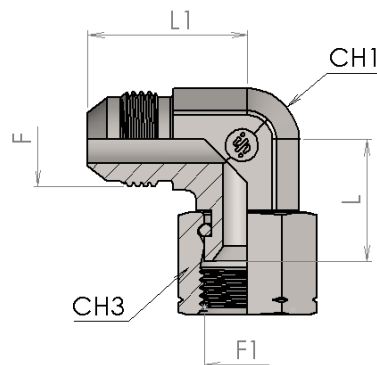

Part number	Dimensions								Weight kg/unit
	Ø		F	F1	L	L1	CH1	CH3	
	tube mm	tube inch							
5060-04	6	1/4"	7/16-20	7/16-20	16.7	22	12	14	0,037
5060-05	8	5/16"	1/2-20	1/2-20	17.4	24	14	17	0,043
5060-06	10	3/8"	9/16-18	9/16-18	22.3	27	14	19	0,054
5060-08	12	1/2"	3/4-16	3/4-16	24.4	32	19	22	0,105
5060-10	16	5/8"	7/8-14	7/8-14	28.4	36	22	27	0,162
5060-12	20	3/4"	1.1/16-12	1.1/16-12	30.1	42	27	32	0,26
5060-16	25	1"	1.5/16-12	1.5/16-12	35.7	46	33	41	0,42
5060-20	30-32	1.1/4"	1.5/8-12	1.5/8-12	42.8	52	41	50	0,679
5060-24	38	1.1/2"	1.7/8-12	1.7/8-12	47.2	59	50	60	0,747

5070

**Girevole a 45° F/M
JIC
(ISO 8434-2)**

SWE45

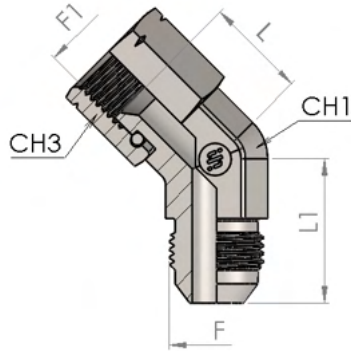

Part number	Dimensions								Weight kg/unit
	Ø		F	F1	L	L1	CH1	CH3	
	tube mm	tube inch							
5070-04	6	1/4"	7/16-20	7/16-20	15	18.5	12	14	0,03
5070-05	8	5/16"	1/2-20	1/2-20	16	19.5	14	17	0,045
5070-06	10	3/8"	9/16-18	9/16-18	19	21	14	19	0,047
5070-08	12	1/2"	3/4-16	3/4-16	22	25	19	22	0,089
5070-10	16	5/8"	7/8-14	7/8-14	24	28	22	27	0,131
5070-12	20	3/4"	1.1/16-12	1.1/16-12	24	32.5	27	32	0,203
5070-16	25	1"	1.5/16-12	1.5/16-12	29.5	37.5	33	41	0,335
5070-20	30-32	1.1/4"	1.5/8-12	1.5/8-12	35.5	40.5	41	50	0,572

Girevole a T laterale F/M JIC (ISO 8434-2)

SWRT

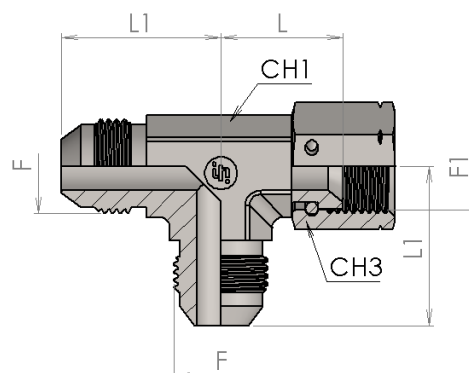

Part number	Dimensions								Weight kg/unit
	Ø		F	F1	L	L1	CH1	CH3	
	tube mm	tube inch							
5080-04	6	1/4"	7/16-20	7/16-20	16.7	22	12	14	0,044
5080-05	8	5/16"	1/2-20	1/2-20	17.4	24	14	17	0,058
5080-06	10	3/8"	9/16-18	9/16-18	22.3	27	14	19	0,071
5080-08	12	1/2"	3/4-16	3/4-16	24.4	32	19	22	0,133
5080-10	16	5/8"	7/8-14	7/8-14	28.4	36	22	27	0,203
5080-12	20	3/4"	1.1/16-12	1.1/16-12	30.1	42	27	32	0,328
5080-16	25	1"	1.5/16-12	1.5/16-12	35.7	46	33	41	0,483
5080-20	30-32	1.1/4"	1.5/8-12	1.5/8-12	42.8	52	41	50	0,7018
5080-24	38	1.1/2"	1.7/8-12	1.7/8-12	47.2	59	50	60	1,1

5090

Girevole a T centrale F/M JIC (ISO 8434-2)

SWBT

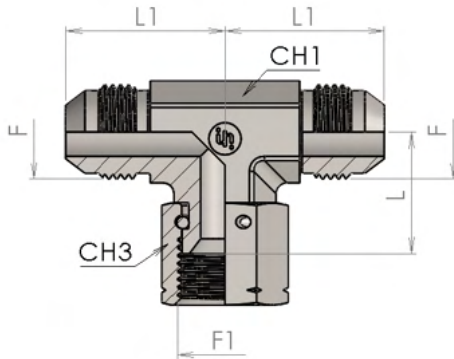

Part number	Dimensions								Weight kg/unit
	Ø		F	F1	L	L1	CH1	CH3	
	tube mm	tube inch							
5090-04	6	1/4"	7/16-20	7/16-20	16.7	22	12	14	0,044
5090-05	8	5/16"	1/2-20	1/2-20	17.4	24	14	17	0,058
5090-06	10	3/8"	9/16-18	9/16-18	22.3	27	14	19	0,071
5090-08	12	1/2"	3/4-16	3/4-16	24.4	32	19	22	0,133
5090-10	16	5/8"	7/8-14	7/8-14	28.4	36	22	27	0,203
5090-12	20	3/4"	1.1/16-12	1.1/16-12	30.1	42	27	32	0,328
5090-16	25	1"	1.5/16-12	1.5/16-12	35.7	46	33	41	0,483
5090-20	30-32	1.1/4"	1.5/8-12	1.5/8-12	42.8	52	41	50	0,7018
5090-24	38	1.1/2"	1.7/8-12	1.7/8-12	47.2	59	50	60	1,1

Passaparete dritto JIC (ISO 8434-2)

BHS

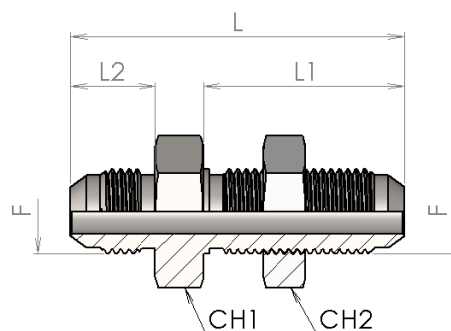

Part number	Dimensions								Weight kg/unit
	Ø		F	L	L1	L2	CH1	CH2	
	tube mm	tube inch							
5110-04	6	1/4"	7/16-20	52.5	30.5	14	17	17	0,04
5110-05	8	5/16"	1/2-20	52.5	30.5	14	19	19	0,048
5110-06	10	3/8"	9/16-18	55.5	32.5	14	22	22	0,065
5110-08	12	1/2"	3/4-16	62	36.5	17	24	24	0,11
5110-10	16	5/8"	7/8-14	69.5	40	19	30	30	0,155
5110-12	20	3/4"	1 1/16-12	78.5	44.5	22	36	36	0,255
5110-16	25	1"	1 5/16-12	80	44.5	23	41	41	0,335
5110-20	32	1.1/4"	1 5/8-12	84	45.5	14	50	50	0,465
5110-24	38	1.1/2"	1 7/8-12	89.5	46	27.5	55	55	0,7

5130

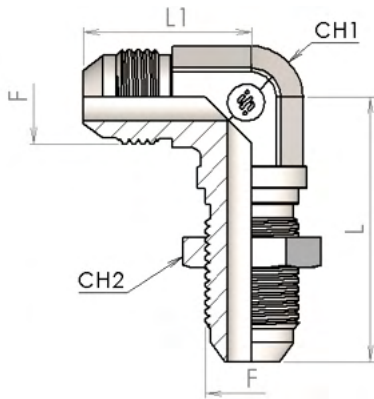

**Passaparete a 90°
JIC
(ISO 8434-2)**

BHE

Part number	Dimensions							Weight kg/unit
	Ø		F	L	L1	CH1	CH2	
	tube mm	tube inch						
5130-04	6	1/4"	7/16-20	40.5	24.5	14	17	0,05
5130-05	8	5/16"	1/2-20	43.5	27	14	19	0,065
5130-06	10	3/8"	9/16-18	46	27.5	14	22	0,072
5130-08	12	1/2"	3/4-16	53.5	34	19	24	0,15
5130-10	16	5/8"	7/8-14	60	39	22	30	0,21
5130-12	20	3/4"	1 1/16-12	68	45	27	36	0,34
5130-16	25	1"	1 5/16-12	71	49.5	33	41	0,45

Controdado per passaparete

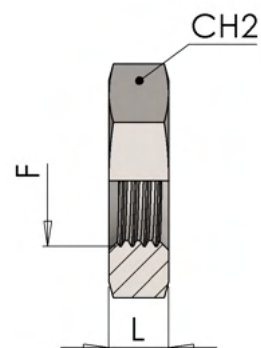

Part number	Dimensions			Weight kg/unit
	F	L	CH2	
J107-04	7/16-20	7	17	0,008
J107-05	1/2-20	7.5	19	0,007
J107-06	9/16-18	7	22	0,011
J107-08	3/4-16	9	24	0,015
J107-10	7/8-14	10	30	0,031
J107-12	1.1/16-12	12	36	0,054
J107-16	1.5/16-12	12	41	0,057
J107-20	1.5/8-12	13	50	0,087
J107-24	1.7/8-12	13	55	0,088

1906

Terminale dritto M/M JIC-NPTF

SDS

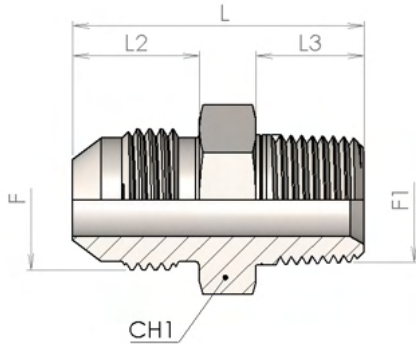

Part number	Dimensions								Weight kg/unit
	Ø		F	F1	L	L2	L3	CH1	
	tube mm	tube inch							
1906-02-04	6	1/4"	7/16-20	1/8-27 NPTF	30	14	10	12	0,014
1906-02-05	8	5/16"	1/2-20	1/8-27 NPTF	31	14	10	14	0,017
1906-04-04	6	1/4"	7/16-20	1/4-18 NPTF	36	14	14.5	14	0,025
1906-04-05	8	5/16"	1/2-20	1/4-18 NPTF	36	14	14.5	14	0,025
1906-04-06	10	3/8"	9/16-18	1/4-18 NPTF	36	14	14.5	17	0,027
1906-06-06	10	3/8"	9/16-18	3/8-18 NPTF	35	14	14.5	19	0,03
1906-06-08	12	1/2"	3/4-16	3/8-18 NPTF	37.5	17	14.5	22	0,045
1906-06-10	16	5/8"	7/8-14	3/8-18 NPTF	43	19	14.5	24	0,063
1906-08-06	10	3/8"	9/16-18	1/2-14 NPTF	41	14	19	22	0,047
1906-08-08	12	1/2"	3/4-16	1/2-14 NPTF	43.5	17	19	22	0,074
1906-08-10	16	5/8"	7/8-14	1/2-14 NPTF	48	19	19	24	0,077
1906-08-12	20	3/4"	1 1/16-12	1/2-14 NPTF	49	22	19	30	0,1
1906-12-10	16	5/8"	7/8-14	3/4-14 NPTF	49.5	19	19	27	0,12
1906-12-12	20	3/4"	1 1/16-12	3/4-14 NPTF	52.5	22	19	30	0,12
1906-12-16	25	1"	1 5/16-12	3/4-14 NPTF	52	23	19	36	0,15
1906-16-12	20	3/4"	1 1/16-12	1-11.1/2 NPTF	56	22	24	36	0,175
1906-16-16	25	1"	1 5/16-12	1-11.1/2 NPTF	58.5	23	24	36	0,19
1906-20-20	32	1.1/4"	1 5/8-12	1.1/4-1.1/2 NPTF	60.5	24	24.6	46	0,315
1906-24-24	38	1.1/2"	1 7/8-12	1.1/2-11.1/2 NPTF	66	27.5	25.5	50	0,43
1906-32-32	50	2"	2 1/2-12	2-11/12 NPTF	77.6	33.9	26.2	65	0,774

Terminale a 90° M/M JIC-NPTF

SDE

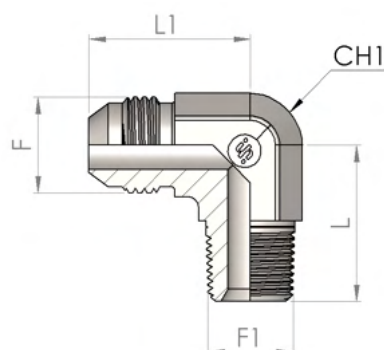

Part number	Dimensions							Weight kg/unit
	Ø		F	F1	L	L1	CH1	
	tube mm	tube inch						
5140-02-04	6	1/4"	7/16-20	1/8-27 NPTF	19.5	22	12	0,023
5140-02-05	8	5/16"	1/2-20	1/8-27 NPTF	24.5	24	14	0,029
5140-04-04	6	1/4"	7/16-20	1/4-18 NPTF	27.5	23	14	0,042
5140-04-05	8	5/16"	1/2-20	1/4-18 NPTF	27.5	24	14	0,042
5140-04-06	10	3/8"	9/16-18	1/4-18 NPTF	27.5	27	14	0,045
5140-06-06	10	3/8"	9/16-18	3/8-18 NPTF	31	29.5	19	0,076
5140-06-08	12	1/2"	3/4-16	3/8-18 NPTF	31	32	19	0,086
5140-06-10	14-16	5/8"	7/8-14	3/8-18 NPTF	33.5	36	22	0,127
5140-08-06	10	3/8"	9/16-18	1/2-14 NPTF	36	31.5	22	0,117
5140-08-08	12	1/2"	3/4-16	1/2-14 NPTF	36	34	22	0,125
5140-08-10	14-16	5/8"	7/8-14	1/2-14 NPTF	36	36	22	0,129
5140-08-12	18-20	3/4"	1.1/16-12	1/2-14 NPTF	38	42	27	0,204
5140-12-08	12	1/2"	3/4-16	3/4-14 NPTF	40.5	37	27	0,19
5140-12-10	14-16	5/8"	7/8-14	3/4-14 NPTF	40.5	39	27	0,192
5140-12-12	18-20	3/4"	1.1/16-12	3/4-14 NPTF	40.5	42	27	0,198
5140-12-16	25	1"	1.5/16-12	3/4-14 NPTF	45	46	33	0,318
5140-16-16	25	1"	1.5/16-12	1-11.1/2 NPTF	50	46	33	0,328
5140-20-20	30-32	1.1/4"	1.5/8-12	1.1/4-11.1/2 NPTF	60.5	52	41	0,549
5140-24-24	38	1.1/2"	1.7/8-12	1.1/2-11.1/2 NPTF	67	59	50	0,747

5150

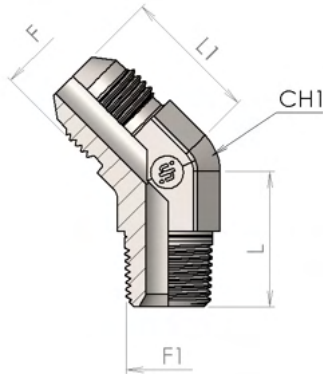

Terminale a 45° M/M JIC-NPTF

SDE45

Part number	Dimensions							Weight kg/unit
	Ø		F	F1	L	L1	CH1	
	tube mm	tube inch						
5150-02-04	6	1/4"	7/16-20	1/8-27 NPTF	16.5	18.5	12	0,02
5150-02-05	8	5/16"	1/2-20	1/8-27 NPTF	16.5	19.5	14	0,025
5150-04-04	6	1/4"	7/16-20	1/4-18 NPTF	22	21	14	0,03
5150-04-05	8	5/16"	1/2-20	1/4-18 NPTF	22	21	14	0,03
5150-04-06	10	3/8"	9/16-18	1/4-18 NPTF	22	21	14	0,027
5150-06-06	10	3/8"	9/16-18	3/8-18 NPTF	24	22	19	0,052
5150-06-08	12	1/2"	3/4-16	3/8-18 NPTF	24	25	19	0,06
5150-06-10	14-16	5/8"	7/8-14	3/8-18 NPTF	25	28	22	0,095
5150-08-08	12	1/2"	3/4-16	1/2-14 NPTF	29.5	25	22	0,092
5150-08-10	14-16	5/8"	7/8-14	1/2-14 NPTF	29.5	28	22	0,092
5150-08-12	18-20	3/4"	1.1/16-12	1/2-14 NPTF	30.5	32.5	27	0,145
5150-12-12	18-20	3/4"	1.1/16-12	3/4-14 NPTF	30.5	32.5	27	0,15
5150-12-16	25	1"	1.5/16-12	3/4-14 NPTF	32.5	37	33	0,215
5150-16-16	25	1"	1.5/16-12	1-11.1/2 NPTF	37.5	37	33	0,24
5150-20-20	30-32	1.1/4"	1.5/8-12	1.1/4-11.1/2 NPTF	42.5	40.5	41	0,385

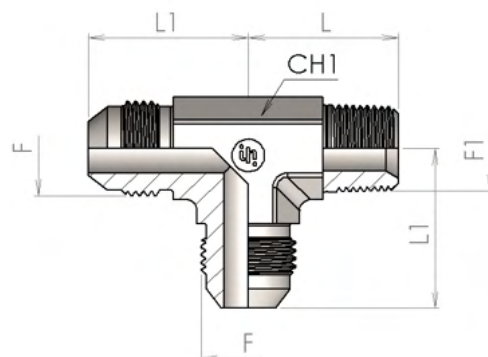
**Terminale a T laterale M/M
JIC-NPTF**
SDRT

Part number	Dimensions							Weight kg/unit
	Ø		F	F1	L	L1	CH1	
	tube mm	tube inch						
5160-02-04	6	1/4"	7/16-20	1/8-27 NPTF	19.5	22	12	0,031
5160-02-05	8	5/16"	1/2-20	1/8-27 NPTF	24.5	24	14	0,037
5160-04-04	6	1/4"	7/16-20	1/4-18 NPTF	27.5	23	14	0,049
5160-04-06	10	3/8"	9/16-18	1/4-18 NPTF	27.5	27	14	0,057
5160-06-06	10	3/8"	9/16-18	3/8-18 NPTF	31	29.5	22	0,077
5160-06-08	12	1/2"	3/4-16	3/8-18 NPTF	31	32	19	0,113
5160-08-08	12	1/2"	3/4-16	1/2-16 NPTF	36	34	19	0,164
5160-08-10	14-16	5/8"	7/8-14	1/2-14 NPTF	36	36	22	0,173
5160-12-12	18-20	3/4"	1.1/16-12	3/4-14 NPTF	40.5	42	27	0,272
5160-16-16	25	1"	1.5/16-12	1-11.1/2 NPTF	50	46	33	0,413
5160-20-20	30-32	1.1/4"	1.5/8-12	1.1/4-11.1/2 NPTF	60.5	52	41	0,681
5160-24-24	38	1.1/2"	1.7/8-12	1.1/2-11.1/2 NPTF	67	59	50	0,905

5170

**Terminale a T centrale M/M
JIC-NPTF**

SDBT

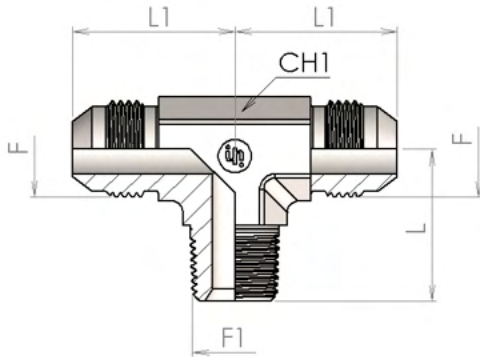

Part number	Dimensions							Weight kg/unit
	Ø		F	F1	L	L1	CH1	
	tube mm	tube inch						
5170-02-04	6	1/4"	7/16-20	1/8-27 NPTF	19.5	22	12	0,031
5170-02-05	8	5/16"	1/2-20	1/8-27 NPTF	24.5	24	14	0,037
5170-04-04	6	1/4"	7/16-20	1/4-18 NPTF	27.5	23	14	0,049
5170-04-06	10	3/8"	9/16-18	1/4-18 NPTF	27.5	27	14	0,057
5170-06-06	10	3/8"	9/16-18	3/8-18 NPTF	31	29.5	19	0,077
5170-06-08	12	1/2"	3/4-16	3/8-18 NPTF	31	32	19	0,113
5170-08-08	12	1/2"	3/4-16	1/2-14 NPTF	36	34	22	0,164
5170-08-10	14-16	5/8"	7/8-14	1/2-14 NPTF	36	36	22	0,173
5170-12-12	18-20	3/4"	1.1/16-12	3/4-14 NPTF	40.5	42	27	0,272
5170-16-16	25	1"	1.5/16-12	1-11.1/2 NPTF	50	46	33	0,413
5170-20-20	30-32	1.1/4"	1.5/8-12	1.1/4-11.1/2 NPTF	60.5	52	41	0,681
5170-24-24	38	1.1/2"	1.7/8-12	1.1/2-11.1/2 NPTF	67	59	50	0,905

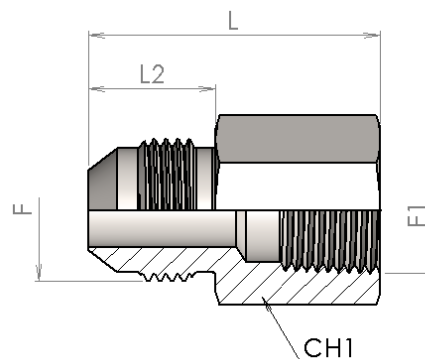
**Terminale dritto M/F fissa
JIC-NPTF**
SWS

Part number	Dimensions							Weight kg/unit
	Ø		F	F1	L	L2	CH1	
	tube mm	tube inch						
5180-02-04	6	1/4"	7/16-20	1/8-27 NPTF	30	14	14	0,045
5180-02-05	8	5/16"	1/2-20	1/8-27 NPTF	30	14	14	0,04
5180-04-05	8	5/16"	1/2-20	1/4-18 NPTF	35.5	14	19	0,045
5180-04-06	10	3/8"	9/16-18	1/4-18 NPTF	35.5	14	19	0,04
5180-06-06	10	3/8"	9/16-18	3/8-18 NPTF	36.5	14	22	0,065
5180-06-08	12	1/2"	3/4-16	3/8-18 NPTF	39.5	17	22	0,045
5180-08-10	16	5/8"	7/8-14	1/2-14 NPTF	48	19.5	30	0,125
5180-12-12	20	3/4"	1.1/16-12	3/4-14 NPTF	52.5	22	36	0,19
5180-16-16	25	1"	1.5/16-12	1-11.1/2 NPTF	59.5	23	41	0,28
5180-20-20	30-32	1.1/4"	1.5/8-12	1.1/4-1.1/2 NPTF	63	24.5	50	0,41
5180-24-24	38	1.1/2"	1.7/8-12	1.1/2-11.1/2 NPTF	66.5	27.5	60	0,37

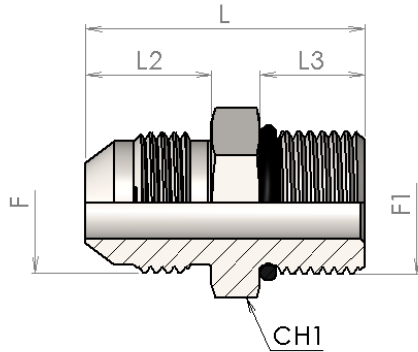

Terminale dritto M/M JIC-UNF (ISO 11926)

SDS

Part number	Dimensions								Weight kg/unit
	Ø		F	F1	L	L2	L3	CH1	
	tube mm	tube inch							
1907-04-04	6	1/4"	7/16-20	7/16-20	31	14	9	14	0,015
1907-04-05	6	1/4"	7/16-20	1/2-20	31	14	9	17	0,025
1907-04-06	6	1/4"	7/16-20	9/16-18	32.5	14	10	17	0,027
1907-05-05	8	5/16"	1/2-20	1/2-20	31	14	9	17	0,02
1907-06-06	10	3/8"	9/16-18	9/16-18	33	14	10	17	0,025
1907-06-08	10	3/8"	9/16-18	3/4-16	35	14	11	22	0,045
1907-08-08	12	1/2"	3/4-16	3/4-16	37.5	17	11	22	0,06
1907-08-10	12	1/2"	3/4-16	7/8-14	40	17	12.5	27	0,075
1907-08-12	12	1/2"	3/4-16	1 1/16-12	44.5	17	15	32	0,125
1907-10-08	14-16	5/8"	7/8-14	3/4-16	40	19	11	24	0,065
1907-10-10	14-16	5/8"	7/8-14	7/8-14	43	19	12.5	27	0,075
1907-10-12	14-16	5/8"	7/8-14	1 1/16-12	47.5	19	15	32	0,135
1907-12-08	18-20	3/4"	1 1/16-12	3/4-16	44.5	22	11	27	0,1
1907-12-10	18-20	3/4"	1 1/16-12	7/8-14	47.5	22	12.5	27	0,11
1907-12-12	18-20	3/4"	1 1/16-12	1 1/16-12	50	22	15	32	0,135
1907-12-16	18-20	3/4"	1 1/16-12	1 5/16-12	51	22	15	38	0,2
1907-16-12	25	1"	1 5/16-12	1 1/16-12	50.5	23	15	36	0,2
1907-16-16	25	1"	1 5/16-12	1 5/16-12	52	23	15	38	0,205
1907-20-20	30-32	1.1/4"	1 5/8-12	1 5/8-12	55	24	15	50	0,364
1907-24-24	38	1.1/2"	1 7/8-12	1 7/8-12	60	27.5	15	55	0,487

Curva Orientabile 90° M/M JIC-UNF (ISO 11926)

SDE

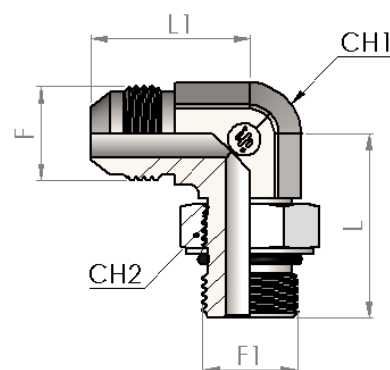

Part number	Dimensions								Weight kg/unit
	Ø		F	F1	L	L1	CH1	CH2	
	tube mm	tube inch							
5190-04	6	1/4"	7/16-20	7/16-20	27	22	12	14	0,037
5190-04-05	8	5/16"	1/2-20	7/16-20	28.5	24	14	14	0,055
5190-05	8	5/16"	1/2-20	1/2-20	30	24	14	17	0,047
5190-05-06	10	3/8"	9/16-18	1/2-20	31.5	27	14	17	0,099
5190-06	10	3/8"	9/16-18	9/16-18	33	27	14	19	0,063
5190-06-08	12	1/2"	3/4-16	9/16-18	35	32	19	19	0,13
5190-08	12	1/2"	3/4-16	3/4-16	37	32	19	24	0,16
5190-08-10	16	5/8"	7/8-14	3/4-16	40	36	22	24	0,18
5190-10	16	5/8"	7/8-14	7/8-14	43	36	22	27	0,186
5190-10-12	20	3/4"	1.1/16-12	7/8-14	46.5	42	27	27	0,297
5190-12	20	3/4"	1.1/16-12	1.1/16-12	50	42	27	36	0,301
5190-12-16	25	1"	1.5/16-12	1.1/16-12	51.5	46	33	36	0,418
5190-16	25	1"	1.5/16-12	1.5/16-12	53	46	33	41	0,426
5190-16-20	30-32	1.1/4"	1.5/8-12	1.5/16-12	55.5	52	41	41	0,65
5190-20	30-32	1.1/4"	1.5/8-12	1.5/8-12	58	52	41	50	0,674
5190-20-24	38	1.1/2"	1.7/8-12	1.5/8-12	60.5	59	50	50	0,92
5190-24	38	1.1/2"	1.7/8-12	1.7/8-12	63	59	50	55	0,917

5200

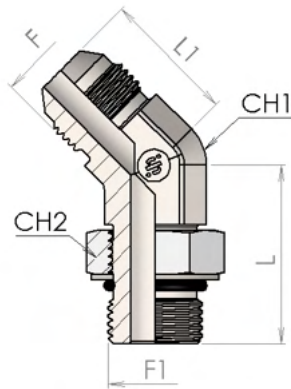

Curva Orientabile 45° M/M JIC-UNF (ISO 11926)

SDE45

Part number	Dimensions								Weight kg/unit
	Ø								
	tube mm	tube inch	F	F1	L	L1	CH1	CH2	
5200-04	6	1/4"	7/16-20	7/16-20	27	20	12	14	0,034
5200-05	8	5/16"	1/2-20	1/2-20	28	21	14	17	0,042
5200-06	10	3/8"	9/16-18	9/16-18	30	21.5	14	19	0,052
5200-08	12	1/2"	3/4-16	3/4-16	33.5	26	19	24	0,104
5200-10	16	5/8"	7/8-14	7/8-14	39	29	22	27	0,157
5200-12	20	3/4"	1.1/16-12	1.1/16-12	44	33	27	36	0,258
5200-16	25	1"	1.5/16-12	1.5/16-12	47	37.5	33	41	0,375
5200-20	30-32	1.1/4"	1.5/8-12	1.5/8-12	48.5	40.5	41	50	0,57

**Terminale a T orientabile
laterale M/M
JIC-UNF
(ISO 11926)**

SDRT

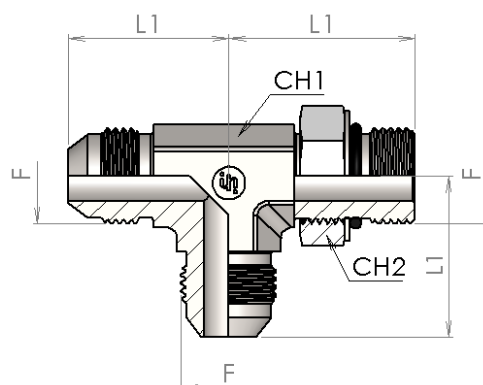

Part number	Dimensions								Weight kg/unit
	Ø		F	F1	L	L1	CH1	CH2	
	tube mm	tube inch							
5210-04	6	1/4"	7/16-20	7/16-20	27	22	12	14	0,046
5210-05	8	5/16"	1/2-20	1/2-20	30	24	14	17	0,066
5210-06	10	3/8"	9/16-18	9/16-18	33	27	14	19	0,076
5210-08	12	1/2"	3/4-16	3/4-16	37	32	19	24	0,15
5210-10	16	5/8"	7/8-14	7/8-14	43	36	22	27	0,224
5210-12	20	3/4"	1.1/16-12	1.1/16-12	50	42	27	36	0,367
5210-16	25	1"	1.5/16-12	1.5/16-12	53	46	33	41	0,506
5210-20	30-32	1.1/4"	1.5/8-12	1.5/8-12	58	52	41	50	1,053
5210-24	38	1.1/2"	1.7/8-12	1.7/8-12	63	59	50	55	1,296

5220

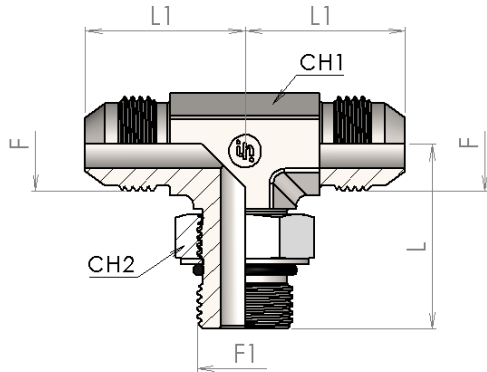

**Terminale a T orientabile
centrale M/M
JIC-UNF
(ISO 11926)**

SDBT

Part number	Dimensions								Weight kg/unit
	Ø								
	tube mm	tube inch	F	F1	L	L1	CH1	CH2	
5220-04	6	1/4"	7/16-20	7/16-20	27	22	12	14	0,046
5220-05	8	5/16"	1/2-20	1/2-20	30	24	14	17	0,066
5220-06	10	3/8"	9/16-18	9/16-18	33	27	14	19	0,076
5220-08	12	1/2"	3/4-16	3/4-16	37	32	19	22	0,15
5220-10	16	5/8"	7/8-14	7/8-14	43	36	22	27	0,224
5220-12	20	3/4"	1.1/16-12	1.1/16-12	50	42	27	36	0,367
5220-16	25	1"	1.5/16-12	1.5/16-12	53	46	33	41	0,506
5220-20	30-32	1.1/4"	1.5/8-12	1.5/8-12	58	52	41	50	1,053
5220-24	38	1.1/2"	1.7/8-12	1.7/8-12	63	59	50	55	1,296

Terminale dritto M/M JIC-BSP (Form E ISO 1179-2)

SDS

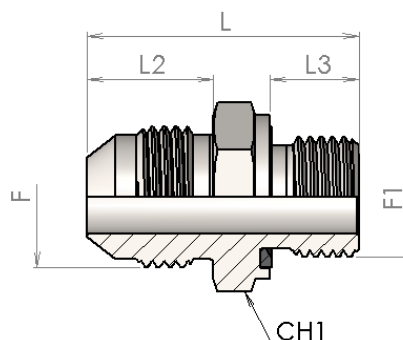

Part number	Dimensions								Weight kg/unit
	Ø		F	F1	L	L2	L3	CH1	
tube mm	tube inch								
5805-02-04	6	1/4"	7/16-20	G 1/8	30	14	8	14	0,02
5805-04-04	6	1/4"	7/16-20	G 1/4	36.5	14	12	19	0,034
5805-04-05	8	5/16"	1/2-20	G 1/4	35	14	12	19	0,03
5805-04-06	10	3/8"	9/16-18	G 1/4	35	14	12	19	0,028
5805-04-08	12	1/2"	3/4-16	G 1/4	39.5	17	12	22	0,04
5805-06-04	6	1/4"	7/16-20	G 3/8	36.5	14	12	22	0,047
5805-06-05	8	5/16"	1/2-20	G 3/8	36.5	14	12	22	0,047
5805-06-06	10	3/8"	9/16-18	G 3/8	36.5	14	12	22	0,04
5805-06-08	12	1/2"	3/4-16	G 3/8	38.5	17	12	22	0,05
5805-06-10	14-16	5/8"	7/8-14	G 3/8	42.5	19	12	24	0,065
5805-08-06	10	3/8"	9/16-18	G 1/2	39	14	14	27	0,095
5805-08-08	12	1/2"	3/4-16	G 1/2	43	17	14	27	0,1
5805-08-10	16	5/8"	7/8-14	G 1/2	44.5	19	14	27	0,103
5805-08-12	18-20	3/4"	1 1/16-12	G 1/2	49	22	14	30	0,118
5805-12-08	12	1/2"	3/4-16	G 3/4	47	17	16	32	0,1
5805-12-10	14-16	5/8"	7/8-14	G 3/4	49.5	19	16	32	0,16
5805-12-12	20	3/4"	1 1/16-12	G 3/4	51	22	16	32	0,165
5805-12-16	25	1"	1 5/16-12	G 3/4	53	23	16	36	0,217
5805-16-12	18-20	3/4"	1 1/16-12	G 1	55	22	18	41	0,292
5805-16-16	25	1"	1 5/16-12	G 1	55	23	18	41	0,262
5805-16-20	30-32	1.1/4"	1 5/8-12	G 1	58	24	18	46	0,255
5805-20-16	25	1"	1 5/16-12	G 1.1/4	59.5	23	20	50	0,386
5805-20-20	30-32	1.1/4"	1 5/8-12	G 1.1/4	60	24	20	50	0,375
5805-20-24	38	1.1/2"	1 7/8-12	G 1.1/4	66	27.5	20	50	0,42
5805-24-24	38	1.1/2"	1 7/8-12	G 1.1/2	67	27.5	22	55	0,48

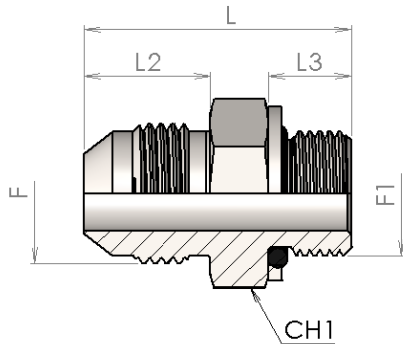

Terminale dritto M/M JIC-BSP (ISO 1179)

SDS

Part number	Dimensions								Weight kg/unit
	Ø		F	F1	L	L2	L3	CH1	
	tube mm	tube inch							
1915-02-04	6	1/4"	7/16-20	G 1/8	30	14	8	14	0,015
1915-02-05	8	5/16"	1/2-20	G 1/8	29	14	8	14	0,02
1915-04-04	6	1/4"	7/16-20	G 1/4	34.5	14	12	19	0,034
1915-04-05	8	5/16"	1/2-20	G 1/4	34	14	12	19	0,03
1915-04-06	10	3/8"	9/16-18	G 1/4	34	14	12	19	0,028
1915-04-08	12	1/2"	3/4-16	G 1/4	37.5	17	12	22	0,045
1915-06-04	6	1/4"	7/16-20	G 3/8	34.5	14	12	22	0,047
1915-06-05	8	5/16"	1/2-20	G 3/8	34.5	14	12	22	0,047
1915-06-06	10	3/8"	9/16-18	G 3/8	34.5	14	12	22	0,04
1915-06-08	12	1/2"	3/4-16	G 3/8	38	17	12	22	0,05
1915-06-10	14-16	5/8"	7/8-14	G 3/8	40	19	12	24	0,065
1915-08-06	10	3/8"	9/16-18	G 1/2	40	14	14	27	0,02
1915-08-08	12	1/2"	3/4-16	G 1/2	41	17	14	27	0,095
1915-08-10	16	5/8"	7/8-14	G 1/2	44	19	14	27	0,095
1915-08-12	18-20	3/4"	1 1/16-12	G 1/2	47	22	14	30	0,115
1915-12-08	12	1/2"	3/4-16	G 3/4	45	17	16	36	0,1
1915-12-10	14-16	5/8"	7/8-14	G 3/4	47	19	16	36	0,16
1915-12-12	20	3/4"	1 1/16-12	G 3/4	50	22	16	36	0,17
1915-12-16	25	1"	1 5/16-12	G 3/4	51	23	16	36	0,175
1915-16-12	18-20	3/4"	1 1/16-12	G 1	52.5	22	18	41	0,21
1915-16-16	25	1"	1 5/16-12	G 1	53.5	23	18	41	0,22
1915-16-20	30-32	1.1/4"	1 5/8-12	G 1	55.5	24	18	46	0,33
1915-20-16	25	1"	1 5/16-12	G 1.1/4	57	23	20	50	0,385
1915-20-20	30-32	1.1/4"	1 5/8-12	G 1.1/4	58	24	20	50	0,33
1915-24-24	38	1.1/2"	1 7/8-12	G 1.1/2	65.5	27.5	22	55	0,48

Terminale dritto M/M JIC-BSP

SDS

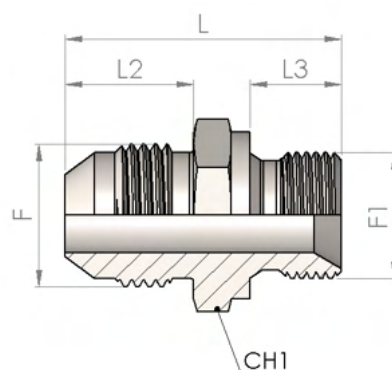

Part number	Dimensions								Weight kg/unit
	Ø		F	F1	L	L2	L3	CH1	
	tube mm	tube inch							
1905-02-04	6	1/4"	7/16-20	G 1/8-28	28.5	14	8	14	0,014
1905-04-04	6	1/4"	7/16-20	G 1/4	33	14	11	19	0,03
1905-04-05	8	5/16"	1/2-20	G 1/4	33	14	11	19	0,03
1905-04-06	10	3/8"	9/16-18	G 1/4	33	14	11	19	0,03
1905-04-08	12	1/2"	3/4-16	G 1/4	38	17	12	22	0,062
1905-06-04	6	1/4"	7/16-20	G 3/8	35.5	14	12	22	0,047
1905-06-05	8	5/16"	1/2-20	G 3/8	35.5	14	12	22	0,047
1905-06-06	10	3/8"	9/16-18	G 3/8	35.5	14	12	22	0,047
1905-06-08	12	1/2"	3/4-16	G 3/8	38	17	12	22	0,062
1905-06-10	16	5/8"	7/8-14	G 3/8	42	19	12	24	0,068
1905-08-06	10	3/8"	9/16-18	G 1/2	39	14	14	27	0,068
1905-08-08	12	1/2"	3/4-16	G 1/2	41.5	17	14	27	0,079
1905-08-10	16	5/8"	7/8-14	G 1/2	44.5	19	14	27	0,085
1905-08-12	20	3/4"	1 1/16-12	G 1/2	47	22	14	27	0,12
1905-12-08	12	1/2"	3/4-16	G 3/4	43.5	17	16	32	0,145
1905-12-10	16	5/8"	7/8-14	G 3/4	46.5	19	16	32	0,155
1905-12-12	20	3/4"	1 1/16-12	G 3/4	49	22	16	32	0,162
1905-12-16	25	1"	1 5/16-12	G 3/4	52	23	16	36	0,175
1905-16-12	20	3/4"	1 1/16-12	G 1	52	22	19	41	0,21
1905-16-16	25	1"	1 5/16-12	G 1	54	23	19	41	0,215
1905-16-20	30	0	1 5/8-12	G 1	57	24	19	42	0,29
1905-20-20	30	0	1 5/8-12	G 1.1/4	58	24	20	50	0,435
1905-24-24	38	1.1/2"	1 7/8-12	G 1.1/2	62.5	27.5	22	55	0,61

Terminale dritto M/F fissa JIC-BSP

SWS

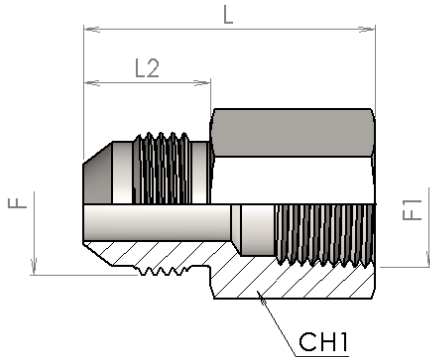

Part number	Dimensions							Weight kg/unit
	Ø		F	F1	L	L2	CH1	
	tube mm	tube inch						
5185-02-04	6	1/4"	7/16-20	G 1/8	30	14	14	0,045
5185-02-05	8	5/16"	1/2-20	G 1/8	30	14	14	0,04
5185-04-04	6	1/4"	7/16-20	G 1/4	35.5	14	19	0,045
5185-04-05	8	5/16"	1/2-20	G 1/4	35.5	14	19	0,045
5185-04-06	10	3/8"	9/16-18	G 1/4	35.5	14	19	0,04
5185-04-08	12	1/2"	3/4-16	G 1/4	38.5	17	22	0,04
5185-06-06	10	3/8"	9/16-18	G 3/8	36.5	14	22	0,065
5185-06-08	12	1/2"	3/4-16	G 3/8	39.5	17	22	0,045
5185-08-06	10	3/8"	9/16-18	G 1/2	43	14	30	0,105
5185-08-08	12	1/2"	3/4-16	G 1/2	45.5	17	30	0,1
5185-08-10	14-16	5/8"	7/8-14	G 1/2	48	19.5	30	0,125
5185-08-12	18-20	3/4"	1.1/16-12	G 1/2	52	22	30	0,125
5185-12-12	18-20	3/4"	1.1/16-12	G 3/4	52.5	22	36	0,19
5185-16-16	25	1"	1.5/16-12	G 1	59.5	23	41	0,28
5185-20-20	30-32	1.1/4"	1.5/8-12	G 1.1/4	63	24.5	50	0,41
5185-24-24	38	1.1/2"	1.7/8-12	G 1.1/2	66.5	27.5	60	0,37

Curva Orientabile 90° M/M JIC-BSP (ISO 1179)

SDE

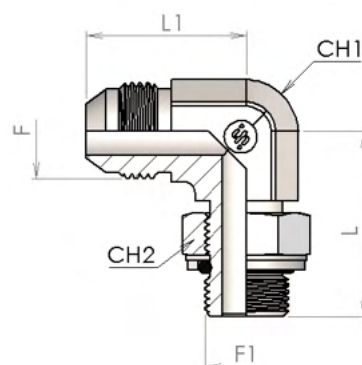

Part number	Dimensions								Weight kg/unit
	Ø		F	F1	L	L1	CH1	CH2	
tube mm	tube inch								
5230-02-04	6	1/4"	7/16-20	G 1/8	27	22	12	14	0,037
5230-02-05	8	5/16"	1/2-20	G 1/8	30	24	14	14	0,047
5230-04-04	6	1/4"	7/16-20	G 1/4	33	23	14	19	0,043
5230-04-05	8	5/16"	1/2-20	G 1/4	33	24	14	19	0,055
5230-04-06	10	3/8"	9/16-18	G 1/4	33	27	14	19	0,061
5230-04-08	12	1/2"	3/4-16	G 1/4	35	32	19	19	0,088
5230-04-10	14-16	5/8"	7/8-14	G 1/4	37	36	22	19	0,095
5230-06-04	6	1/4"	7/16-20	G 3/8	37	27	19	22	0,05
5230-06-05	8	5/16"	1/2-20	G 3/8	37	28	19	22	0,057
5230-06-06	10	3/8"	9/16-18	G 3/8	37	29.5	19	22	0,087
5230-06-08	12	1/2"	3/4-16	G 3/8	37	32	19	22	0,092
5230-06-10	14-16	5/8"	7/8-14	G 3/8	40	36	22	22	0,19
5230-08-04	6	1/4"	7/16-20	G 1/2	43	29	22	27	0,127
5230-08-05	8	5/16"	1/2-20	G 1/2	43	30	22	27	0,135
5230-08-06	10	3/8"	9/16-18	G 1/2	43	31.5	22	27	0,14
5230-08-08	12	1/2"	3/4-16	G 1/2	43	34	22	27	0,155
5230-08-10	14-16	5/8"	7/8-14	G 1/2	43	36	22	27	0,164
5230-08-12	18-20	3/4"	1.1/16-12	G 1/2	46.5	42	27	27	0,245
5230-12-08	12	1/2"	3/4-16	G 3/4	50	37	27	36	0,205
5230-12-10	14-16	5/8"	7/8-14	G 3/4	50	39	27	36	0,217
5230-12-12	18-20	3/4"	1.1/16-12	G 3/4	50	42	27	36	0,295
5230-12-16	25	1"	1.5/16-12	G 3/4	51.5	46	33	36	0,405
5230-16-12	18-20	3/4"	1.1/16-12	G 1	53	44	33	41	0,317
5230-16-16	25	1"	1.5/16-12	G 1	53	46	33	41	0,425
5230-16-20	30-32	1.1/4"	1.5/8-12	G 1	55.5	52	41	41	0,65
5230-20-16	25	1"	1.5/16-12	G 1.1/4-11	58	49	41	50	0,672
5230-20-20	30-32	1.1/4"	1.5/8-12	G 1.1/4-11	58	52	41	50	0,697
5230-24-24	38	1.1/2"	1.7/8-12	G 1.1/2-11	63	59	50	55	0,953
5230-20-24	38	1.1/2"	1.7/8-12	G 1.1/4-11	63	55.5	50	50	0,964

Curva Orientabile 45° M/M JIC-BSP (ISO 1179)

SDE45

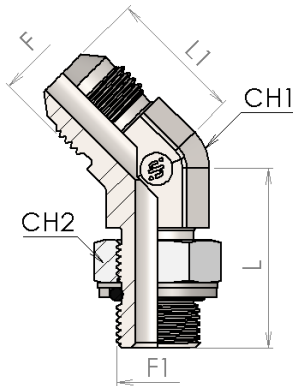

Part number	Dimensions								Weight kg/unit
	Ø		F	F1	L	L1	CH1	CH2	
	tube mm	tube inch							
5235-02-04	6	1/4"	7/16-20	G 1/8	27	21	12	14	0,035
5235-02-05	8	5/16"	1/2-20	G 1/8	28.5	21.5	14	14	0,044
5235-04-04	6	1/4"	7/16-20	G 1/4	30	21.5	14	19	0,048
5235-04-05	8	5/16"	1/2-20	G 1/4	30	21.5	14	19	0,051
5235-04-06	10	3/8"	9/16-18	G 1/4	30	21.5	14	19	0,055
5235-06-04	6	1/4"	7/16-20	G 3/8	33.5	23.5	19	22	0,063
5235-06-05	8	5/16"	1/2-20	G 3/8	33.5	23	19	22	0,066
5235-06-06	10	3/8"	9/16-18	G 3/8	33.5	22	19	22	0,07
5235-06-08	12	1/2"	3/4-16	G 3/8	33.5	26	19	22	0,104
5235-08-06	10	3/8"	9/16-18	G 1/2	39	25.5	22	27	0,092
5235-08-08	12	1/2"	3/4-16	G 1/2	39	27.5	22	27	0,148
5235-08-10	14-16	5/8"	7/8-14	G 1/2	39	29	22	27	0,165
5235-08-12	18-20	3/4"	1.1/16-12	G 1/2	41.5	33	27	27	0,182
5235-12-08	12	1/2"	3/4-16	G 3/4	44	29.5	27	36	0,218
5235-12-10	14-16	5/8"	7/8-14	G 3/4	44	31	27	36	0,235
5235-12-12	18-20	3/4"	1.1/16-12	G 3/4	44	33	27	36	0,27
5235-12-16	25	1"	1.5/16-12	G 3/4	45.5	37.5	33	36	0,31
5235-16-16	25	1"	1.5/16-12	G 1	47	37.5	33	41	0,394
5235-20-20	30-32	1.1/4"	1.5/8-12	G 1.1/4	48.5	40.5	41	50	0,599

Terminale a T orientabile laterale M/M JIC-BSP (ISO 1179)

SDRT

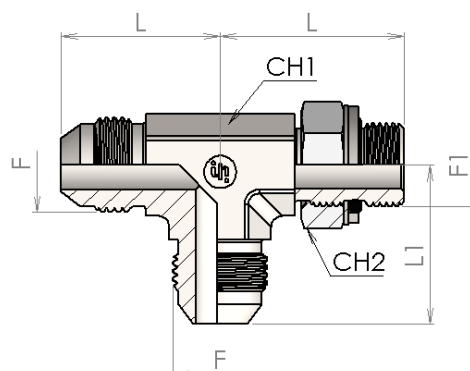

Part number	Dimensions								Weight kg/unit
	Ø		F	F1	L	L1	CH1	CH2	
	tube mm	tube inch							
5240-02-04	6	1/4"	7/16-20	G 1/8	27	22	12	14	0,047
5240-02-05	8	5/16"	1/2-20	G 1/8	30	24	14	14	0,061
5240-04-04	6	1/4"	7/16-20	G 1/4	33	23	14	19	0,06
5240-04-05	8	5/16"	1/2-20	G 1/4	33	24	14	19	0,072
5240-04-06	10	3/8"	9/16-18	G 1/4	33	27	14	19	0,078
5240-06-04	8	5/16"	7/16-20	G 3/8	37	27	19	22	0,1
5240-06-06	10	3/8"	9/16-18	G 3/8	37	29.5	19	22	0,148
5240-06-08	12	1/2"	3/4-16	G 3/8	37	32	19	22	0,154
5240-06-10	14-16	5/8"	7/8-14	G 3/8	40	36	22	22	0,24
5240-08-06	10	3/8"	9/16-18	G 1/2	43	31.5	22	27	0,148
5240-08-08	12	1/2"	3/4-16	G 1/2	43	34	22	27	0,223
5240-08-10	14-16	5/8"	7/8-14	G 1/2	43	36	22	27	0,231
5240-08-12	18-20	3/4"	1.1/16-12	G 1/2	46.5	42	27	27	0,314
5240-12-08	12	1/2"	3/4-16	G 3/4	50	37	27	36	0,289
5240-12-10	14-16	5/8"	7/8-14	G 3/4	50	39	27	36	0,301
5240-12-12	18-20	3/4"	1.1/16-12	G 3/4	50	42	27	36	0,379
5240-12-16	25	1"	1.5/16-12	G 3/4	51.5	46	33	36	0,489
5240-16-12	18-20	3/4"	1.1/16-12	G 1	53	44	33	41	0,461
5240-16-16	25	1"	1.5/16-12	G 1	53	46	33	41	0,569
5240-20-20	30-32	1.1/4"	1.5/8-12	G 1.1/4-11	58	52	41	50	1,075
5240-24-24	38	1.1/2"	1.7/8-12	G 1.1/2-11	63	59	50	55	1,3

5250

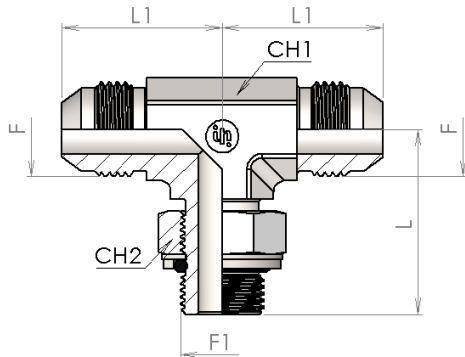

Terminale a T orientabile centrale M/M JIC-BSP (ISO 1179)

SDBT

Part number	Dimensions								Weight kg/unit
	Ø								
	tube mm	tube inch	F	F1	L	L1	CH1	CH2	
5250-02-04	6	1/4"	7/16-20	G 1/8	27	22	12	14	0,047
5250-02-05	8	5/16"	1/2-20	G 1/8	30	24	14	14	0,061
5250-04-04	6	1/4"	7/16-20	G 1/4	33	23	14	19	0,06
5250-04-05	8	5/16"	1/2-20	G 1/4	33	24	14	19	0,072
5250-04-06	10	3/8"	9/16-18	G 1/4	33	27	14	19	0,078
5250-06-04	8	5/16"	7/16-20	G 3/8	37	27	19	22	0,1
5250-06-06	10	3/8"	9/16-18	G 3/8	37	29,5	19	22	0,148
5250-06-08	12	1/2"	3/4-16	G 3/8	37	32	19	22	0,154
5250-06-10	14-16	5/8"	7/8-14	G 3/8	40	36	22	22	0,24
5250-08-06	10	3/8"	9/16-18	G 1/2	43	31,5	22	27	0,148
5250-08-08	12	1/2"	3/4-16	G 1/2	43	34	22	27	0,223
5250-08-10	14-16	5/8"	7/8-14	G 1/2	43	36	22	27	0,231
5250-08-12	18-20	3/4"	1.1/16-12	G 1/2	46,5	42	27	27	0,314
5250-12-08	12	1/2"	3/4-16	G 3/4	50	37	27	36	0,289
5250-12-10	14-16	5/8"	7/8-14	G 3/4	50	39	27	36	0,301
5250-12-12	18-20	3/4"	1.1/16-12	G 3/4	50	42	27	36	0,379
5250-12-16	25	1"	1.5/16-12	G 3/4	51,5	46	33	36	0,489
5250-16-12	18-20	3/4"	1.1/16-12	G 1	53	44	33	41	0,461
5250-16-16	25	1"	1.5/16-12	G 1	53	46	33	41	0,569
5250-20-20	30-32	1.1/4"	1.5/8-12	G 1.1/4-11	58	52	41	50	1,075
5250-24-24	38	1.1/2"	1.7/8-12	G 1.1/2-11	63	59	50	55	1,3

Terminale dritto M/M JIC-METRICO (ISO 6149)

SDS

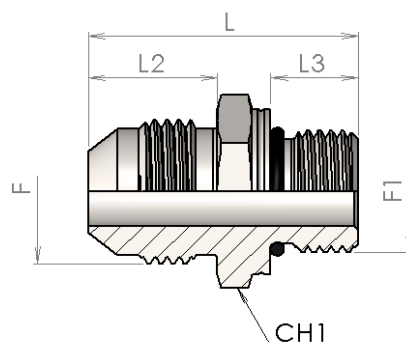

Part number	Dimensions								Weight kg/unit
	Ø		F	F1	L	L2	L3	CH1	
	tube mm	tube inch							
1910-10-04	6	1/4"	7/16-20	M10x1	30	14	8.5	14	0,025
1910-10-05	8	5/16"	1/2-20	M10x1	30	14	8.5	14	0,03
1910-12-04	6	1/4"	7/16-20	M12x1,5	33	14	11	17	0,033
1910-12-05	8	5/16"	1/2-20	M12x1,5	32.5	14	11	17	0,037
1910-14-06	10	3/8"	9/16-18	M14x1,5	33.5	14	11	19	0,045
1910-16-06	10	3/8"	9/16-18	M16x1,5	35	14	11.5	22	0,055
1910-16-08	12	1/2"	3/4-16	M16x1,5	38	17	11.5	22	0,058
1910-18-08	12	1/2"	3/4-16	M18x1,5	39.5	17	12.5	24	0,075
1910-18-10	14-16	5/8"	7/8-14	M18x1,5	42	19	12.5	24	0,075
1910-22-10	14-16	5/8"	7/8-14	M22x1,5	43	19	13	27	0,1
1910-22-12	18-20	3/4"	1 1/16-12	M22x1,5	48	22	13	27	0,105
1910-27-12	18-20	3/4"	1 1/16-12	M27x2	49	22	16	32	0,16
1910-27-16	25	1"	1 5/16-12	M27x2	50.5	23	16	36	0,21
1910-33-16	25	1"	1 5/16-12	M33x2	51	23	16	41	0,275
1910-42-20	30-32	1.1/4"	1 5/8-12	M42x2	54.5	24	16	50	0,435
1910-48-24	38	1.1/2"	1 7/8-12	M48x2	59	27.5	17.5	55	0,57

5430

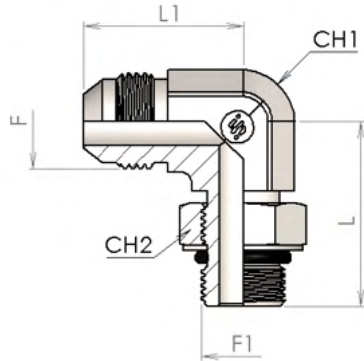

Curva Orientabile 90° M/M JIC-METRICO (ISO 6149)

SDE

Part number	Dimensions								Weight kg/unit
	Ø		F	F1	L	L1	CH1	CH2	
	tube mm	tube inch							
5430-10-04	6	1/4"	7/16-20	M10x1	29	22	12	14	0,023
5430-12-04	6	1/4"	7/16-20	M12x1.5	33	23	14	17	0,028
5430-14-06	10	3/8"	9/16-18	M14x1.5	34	27	14	19	0,036
5430-16-06	10	3/8"	9/16-18	M16x1.5	38	29.5	19	22	0,074
5430-16-08	12	1/2"	3/4-16	M16x1.5	38	32	19	22	0,077
5430-18-08	12	1/2"	3/4-16	M18x1.5	41	32	19	24	0,078
5430-22-10	16	5/8"	7/8-14	M22x1.5	43	36	22	27	0,119
5430-27-12	20	3/4"	1.1/16-12	M27x2	52	42	27	32	0,208
5430-33-16	25	1"	1.5/16-12	M33x2	54	46	33	41	0,333
5430-42-20	30	1.1/4"	1.5/8-12	M42x2	60	52	41	50	0,575

Curva Orientabile 45° M/M JIC-METRICO (ISO 6149)

SDE45

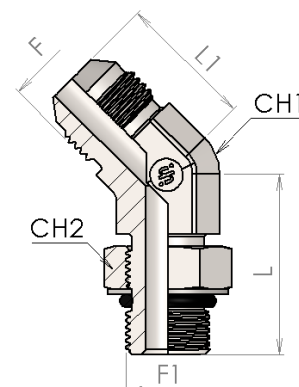

Part number	Dimensions								Weight kg/unit
	Ø		F	F1	L	L1	CH1	CH2	
	tube mm	tube inch							
5440-10-04	6	1/4"	7/16-20	M10x1	27	21	12	14	0,017
5440-12-04	6	1/4"	7/16-20	M12x1.5	30	21.5	14	17	0,025
5440-14-06	10	3/8"	9/16-18	M14x1.5	32	21.5	14	19	0,031
5440-16-06	10	3/8"	9/16-18	M16x1.5	34	23.5	19	22	0,058
5440-16-08	12	1/2"	3/4-16	M16x1.5	34	26	19	22	0,065
5440-18-08	12	1/2"	3/4-16	M18x1.5	36	26	19	24	0,066
5440-22-10	16	5/8"	7/8-14	M22x1.5	38	29	22	27	0,099
5440-27-12	20	3/4"	1.1/16-12	M27x2	45	33	27	32	0,173
5440-33-16	25	1"	1.5/16-12	M33x2	48	37.5	33	41	0,287
5440-42-20	30	1.1/4"	1.5/8-12	M42x2	48.5	40.5	41	50	0,482

5450

Terminale a T orientabile laterale M/M JIC-METRICO (ISO 6149)

SDRT

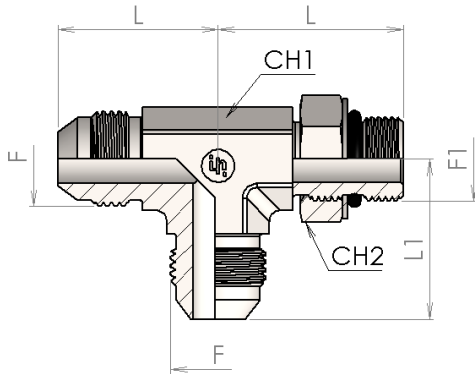

Part number	Dimensions								Weight kg/unit
	Ø		F	F1	L	L1	CH1	CH2	
tube mm	tube inch								
5450-10-04	6	1/4"	7/16-20	M10x1	29	22	12	14	0,027
5450-12-04	6	1/4"	7/16-20	M12x1.5	33	23	14	17	0,041
5450-14-06	10	3/8"	9/16-18	M14x1.5	34	27	14	19	0,053
5450-16-06	10	3/8"	9/16-18	M16x1.5	38	29.5	19	22	0,092
5450-16-08	12	1/2"	3/4-16	M16x1.5	38	32	19	22	0,095
5450-18-08	12	1/2"	3/4-16	M18x1.5	41	32	19	24	0,114
5450-22-10	16	5/8"	7/8-14	M22x1.5	43	36	22	27	0,175
5450-27-12	20	3/4"	1.1/16-12	M27x2	52	42	27	32	0,304
5450-33-16	25	1"	1.5/16-12	M33x2	54	46	33	41	0,491
5450-42-20	30	1.1/4"	1.5/8-12	M42x2	60	52	41	50	0,772
5450-48-24	38	1.1/2"	1.7/8-12	M48x2	67	59	50	55	1,069

**Terminale a T orientabile
centrale M/M
JIC-METRICO
(ISO 6149)**

SDBT

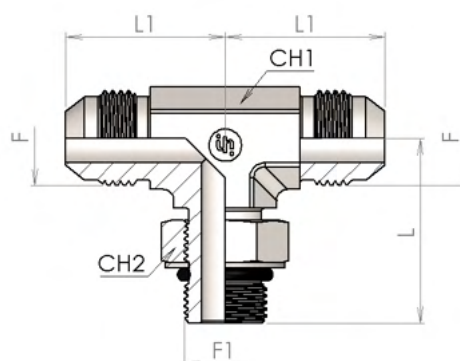

Part number	Dimensions								Weight kg/unit
	Ø		F	F1	L	L1	CH1	CH2	
	tube mm	tube inch							
5455-10-04	6	1/4"	7/16-20	M10x1	29	22	12	14	0,027
5455-12-04	6	1/4"	7/16-20	M12x1.5	33	23	14	17	0,041
5455-14-06	10	3/8"	9/16-18	M14x1.5	34	27	14	19	0,053
5455-16-06	10	3/8"	9/16-18	M16x1.5	38	29.5	19	22	0,092
5455-16-08	12	1/2"	3/4-16	M16x1.5	38	32	19	22	0,095
5455-18-08	12	1/2"	3/4-16	M18x1.5	41	32	19	24	0,114
5455-22-10	16	5/8"	7/8-14	M22x1.5	43	36	22	27	0,175
5455-27-12	20	3/4"	1.1/16-12	M27x2	52	42	27	32	0,304
5455-33-16	25	1"	1.5/16-12	M33x2	54	46	33	41	0,491
5455-42-20	30	1.1/4"	1.5/8-12	M42x2	60	52	41	50	0,772
5455-48-24	38	1.1/2"	1.7/8-12	M48x2	67	59	50	55	1,069

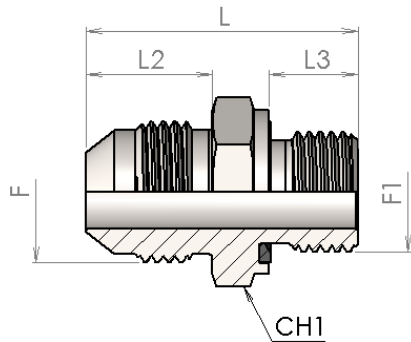

Terminale dritto M/M JIC-METRICO (Form E ISO 9974-2)

SDS

Part number	Dimensions								Weight kg/unit
	Ø		F	F1	L	L2	L3	CH1	
	tube mm	tube inch							
1775-10-04	6	1/4"	7/16-20	M10x1	30	14	8	14	0,02
1775-10-05	8	5/16"	1/2-20	M10x1	30	14	8	14	0,017
1775-12-04	6	1/4"	7/16-20	M12x1,5	34	14	12	17	0,03
1775-12-05	8	5/16"	1/2-20	M12x1,5	34	14	12	17	0,028
1775-14-06	10	3/8"	9/16-18	M14x1,5	34	14	12	19	0,037
1775-16-06	10	3/8"	9/16-18	M16x1,5	36	14	12	22	0,05
1775-16-08	12	1/2"	3/4-16	M16x1,5	39	17	12	22	0,055
1775-18-08	12	1/2"	3/4-16	M18x1,5	39	17	12	24	0,07
1775-18-10	14-16	5/8"	7/8-14	M18x1,5	42	19	12	24	0,105
1775-22-10	14-16	5/8"	7/8-14	M22x1,5	45	19	14	27	0,16
1775-22-12	18-20	3/4"	1 1/16-12	M22x1,5	48	22	14	27	0,27
1775-27-12	18-20	3/4"	1 1/16-12	M27x2	51	22	16	32	0,43
1775-27-16	25	1"	1 5/16-12	M27x2	53	23	16	36	0,36
1775-33-16	25	1"	1 5/16-12	M33x2	55	23	18	41	0,43
1775-42-20	30-32	1.1/4"	1 5/8-12	M42x2	60	24	20	50	0,435
1775-48-24	38	1.1/2"	1 7/8-12	M48x2	67	27.5	22	55	0,58

Terminale dritto M/M JIC-METRICO con o-ring ed anello

SDS

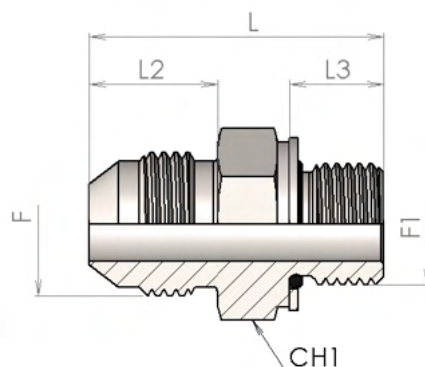

Part number	Dimensions								Weight kg/unit
	Ø		F	F1	L	L2	L3	CH1	
	tube mm	tube inch							
1777-10-04	6	1/4"	7/16-20	M10x1	30	14	9	14	0,025
1777-10-05	8	5/16"	1/2-20	M10x1	30	14	9	14	0,025
1777-12-04	6	1/4"	7/16-20	M12x1,5	32.5	14	11.5	17	0,035
1777-12-05	8	5/16"	1/2-20	M12x1,5	32.5	14	11.5	17	0,035
1777-14-06	10	3/8"	9/16-18	M14x1,5	33.5	14	11.5	19	0,035
1777-16-06	10	3/8"	9/16-18	M16x1,5	34.5	14	12.5	22	0,05
1777-16-08	12	1/2"	3/4-16	M16x1,5	37.5	17	12.5	22	0,055
1777-18-08	12	1/2"	3/4-16	M18x1,5	39.5	17	13.5	24	0,065
1777-18-10	14-16	5/8"	7/8-14	M18x1,5	42	19	13.5	24	0,07
1777-22-10	14-16	5/8"	7/8-14	M22x1,5	44.5	19	15	27	0,09
1777-22-12	18-20	3/4"	1 1/16-12	M22x1,5	48	22	15	27	0,1
1777-27-12	18-20	3/4"	1 1/16-12	M27x2	52.5	22	18.5	32	0,155
1777-27-16	25	1"	1 5/16-12	M27x2	53.5	23	18.5	36	0,2
1777-33-16	25	1"	1 5/16-12	M33x2	54	23	18.5	41	0,265
1777-42-20	30-32	1.1/4"	1 5/8-12	M42x2	58	24	19.5	50	0,425
1777-48-24	38	1.1/2"	1 7/8-12	M48x2	65	27.5	21.5	55	0,545

5400

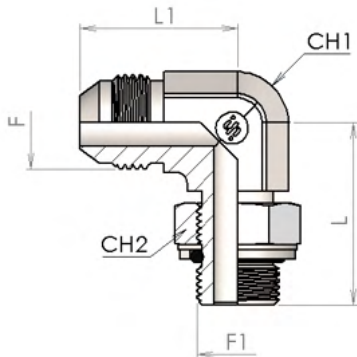

Curva Orientabile 90° M/M JIC-METRICO con o-ring ed anello

SDE

Part number	Dimensions								Weight kg/unit
	Ø		F	F1	L	L1	CH1	CH2	
	tube mm	tube inch							
5400-10-04	6	1/4"	7/16-20	M10x1	29	22	12	14	0,023
5400-10-05	8	5/16"	1/2-20	M10x1	31	24	14	14	0,029
5400-12-04	6	1/4"	7/16-20	M12x1.5	33	23	14	17	0,028
5400-12-05	8	5/16"	1/2-20	M12x1.5	33	24	14	17	0,029
5400-14-04	6	1/4"	7/16-20	M14x1.5	34	23	14	19	0,025
5400-14-05	8	5/16"	1/2-20	M14x1.5	34	24	14	19	0,03
5400-14-06	10	3/8"	9/16-18	M14x1.5	34	27	14	19	0,036
5400-16-06	10	3/8"	9/16-18	M16x1.5	38	29.5	19	22	0,074
5400-16-08	12	1/2"	3/4-16	M16x1.5	38	32	19	22	0,077
5400-18-08	12	1/2"	3/4-16	M18x1.5	41	32	19	24	0,078
5400-18-10	16	5/8"	7/8-14	M18x1.5	42	36	22	24	0,104
5400-22-10	16	5/8"	7/8-14	M22x1.5	43	36	22	27	0,119
5400-22-12	20	3/4"	1.1/16-12	M22x1.5	47.5	42	27	27	0,198
5400-27-12	20	3/4"	1.1/16-12	M27x2	52	42	27	32	0,208
5400-27-16	25	1"	1.5/16-12	M27x2	53	46	33	32	0,333
5400-33-12	20	3/4"	1.1/16-12	M33x2	54	44	33	41	0,317
5400-33-16	25	1"	1.5/16-12	M33x2	54	46	33	41	0,333
5400-42-12	20	3/4"	1.1/16-12	M42x2	60	48	41	50	0,517
5400-42-16	25	1"	1.5/16-12	M42x2	60	46	41	50	0,546
5400-42-20	30	1.1/4"	1.5/8-12	M42x2	60	52	41	50	0,575
5400-48-20	30	1.1/4"	1.5/8-12	M48x2	67	55.5	50	55	0,725
5400-48-24	38	1.1/2"	1.7/8-12	M48x2	67	59	50	55	0,872

Curva Orientabile 45° M/M JIC-METRICO con o-ring e anello

SDE45

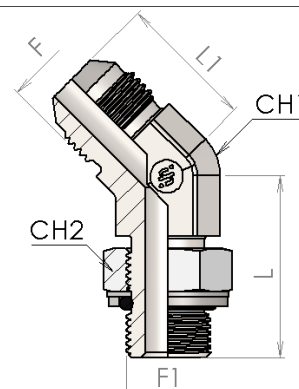

Part number	Dimensions								Weight kg/unit
	Ø		F	F1	L	L1	CH1	CH2	
	tube mm	tube inch							
5410-10-04	6	1/4"	7/16-20	M10x1	27	21	12	14	0,023
5410-10-05	8	5/16"	1/2-20	M10x1	28.5	21.5	14	14	0,031
5410-12-04	6	1/4"	7/16-20	M12x1.5	30	21.5	14	17	0,025
5410-12-05	8	5/16"	1/2-20	M12x1.5	30	21.5	14	17	0,028
5410-14-05	8	5/16"	1/2-20	M14x1.5	32	21.5	14	19	0,031
5410-14-06	10	3/8"	9/16-18	M14x1.5	32	21.5	14	19	0,036
5410-16-06	10	3/8"	9/16-18	M16x1.5	34	23.5	19	22	0,058
5410-16-08	12	1/2"	3/4-16	M16x1.5	34	26	19	22	0,068
5410-18-08	12	1/2"	3/4-16	M18x1.5	36	26	19	24	0,078
5410-18-10	16	5/8"	7/8-14	M18x1.5	37	29	22	24	0,099
5410-22-10	16	5/8"	7/8-14	M22x1.5	38	29	22	27	0,119
5410-22-12	20	3/4"	1.1/16-12	M22x1.5	41.5	33	27	27	0,164
5410-27-12	20	3/4"	1.1/16-12	M27x2	45	33	27	32	0,208
5410-27-16	25	1"	1.5/16-12	M27x2	46.5	37.5	33	32	0,272
5410-33-16	25	1"	1.5/16-12	M33x2	48	37.5	33	41	0,287
5410-42-20	30	1.1/4"	1.5/8-12	M42x2	48,5	40,5	41	50	0,575

5420

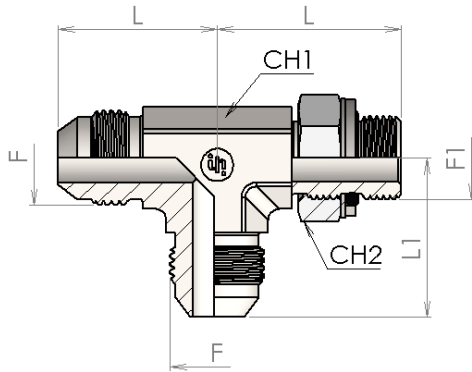

**Terminale a T orientabile
laterale M/M
JIC-METRICO
con o-ring ed anello**

SDRT

Part number	Dimensions								Weight kg/unit
	Ø		F	F1	L	L1	CH1	CH2	
	tube mm	tube inch							
5420-10-04	6	1/4"	7/16-20	M10x1	29	22	12	14	0,027
5420-10-05	8	5/16"	1/2-20	M10x1	31	24	14	14	0,033
5420-12-04	6	1/4"	7/16-20	M12x1.5	33	23	14	17	0,041
5420-12-05	8	5/16"	1/2-20	M12x1.5	33	24	14	17	0,042
5420-14-05	8	5/16"	1/2-20	M14x1.5	34	24	14	19	0,050
5420-14-06	10	3/8"	9/16-18	M14x1.5	34	27	14	19	0,053
5420-16-06	10	3/8"	9/16-18	M16x1.5	38	29.5	19	22	0,092
5420-16-08	12	1/2"	3/4-16	M16x1.5	38	32	19	22	0,113
5420-18-08	12	1/2"	3/4-16	M18x1.5	41	32	19	24	0,114
5420-18-10	16	5/8"	7/8-14	M18x1.5	42	36	22	24	0,174
5420-22-10	16	5/8"	7/8-14	M22x1.5	43	36	22	27	0,175
5420-22-12	20	3/4"	1.1/16-12	M22x1.5	47.5	42	27	27	0,295
5420-27-12	20	3/4"	1.1/16-12	M27x2	52	42	27	32	0,304
5420-27-16	25	1"	1.5/16-12	M27x2	53	46	33	32	0,490
5420-33-16	25	1"	1.5/16-12	M33x2	54	46	33	41	0,530
5420-42-20	30	1.1/4"	1.5/8-12	M42x2	60	52	41	50	0,772
5420-48-24	38	1.1/2"	1.7/8-12	M48x2	67	59	50	55	1,069

**Terminale a T orientabile
centrale M/M
JIC-METRICO
con o-ring ed anello**

SDBT

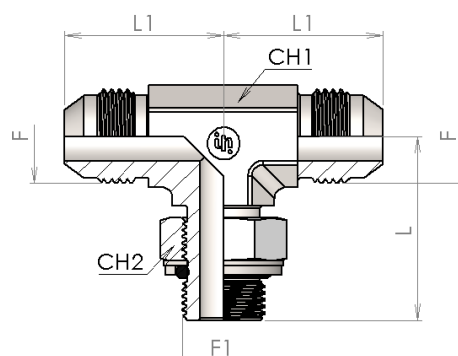

Part number	Dimensions								Weight kg/unit
	Ø		F	F1	L	L1	CH1	CH2	
	tube mm	tube inch							
5425-10-04	6	1/4"	7/16-20	M10x1	29	22	12	14	0,027
5425-10-05	8	5/16"	1/2-20	M10x1	31	24	14	14	0,033
5425-12-04	6	1/4"	7/16-20	M12x1.5	33	23	14	17	0,041
5425-12-05	8	5/16"	1/2-20	M12x1.5	33	24	14	17	0,042
5425-14-05	8	5/16"	1/2-20	M14x1.5	34	24	14	19	0,050
5425-14-06	10	3/8"	9/16-18	M14x1.5	34	27	14	19	0,053
5425-16-06	10	3/8"	9/16-18	M16x1.5	38	29.5	19	22	0,092
5425-16-08	12	1/2"	3/4-16	M16x1.5	38	32	19	22	0,095
5425-18-08	12	1/2"	3/4-16	M18x1.5	41	32	19	24	0,114
5425-18-10	16	5/8"	7/8-14	M18x1.5	42	36	22	24	0,174
5425-22-10	16	5/8"	7/8-14	M22x1.5	43	36	22	27	0,175
5425-22-12	20	3/4"	1.1/16-12	M22x1.5	47.5	42	27	27	0,295
5425-27-12	20	3/4"	1.1/16-12	M27x2	52	42	27	32	0,304
5425-27-16	25	1"	1.5/16-12	M27x2	53	46	33	32	0,490
5425-33-16	25	1"	1.5/16-12	M33x2	54	46	33	41	0,530
5425-42-20	30	1.1/4"	1.5/8-12	M42x2	60	52	41	50	0,772
5425-48-24	38	1.1/2"	1.7/8-12	M48x2	67	59	50	55	1,069

Giunzione M/M Jic/Gas Conico

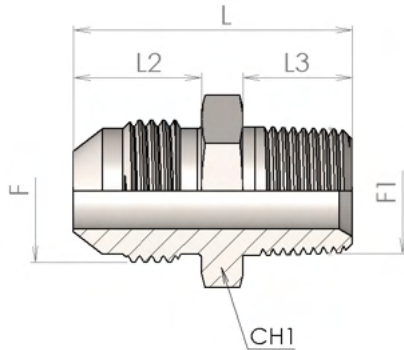

Part number	Dimensions								Weight kg/unit
	Ø		F	F1	L	L2	L3	CH1	
tube mm	tube inch								
1903-02-04	6	1/4"	7/16-20	1/8-28 BSPT	30	14	10	12	0,014
1903-02-05	8	5/16"	1/2-20	1/8-28 BSPT	31	14	10	14	0,017
1903-04-04	6	1/4"	7/16-20	1/4-19 BSPT	36	14	14.5	14	0,025
1903-04-05	8	5/16"	1/2-20	1/4-19 BSPT	36	14	14.5	14	0,025
1903-04-06	10	3/8"	9/16-18	1/4-19 BSPT	36	14	14.5	17	0,03
1903-06-06	10	3/8"	9/16-18	3/8-19 BSPT	36	14	14.5	19	0,027
1903-06-08	12	1/2"	3/4-16	3/8-19 BSPT	37.5	17	14.5	22	0,045
1903-06-10	14-16	5/8"	7/8-14	3/8-19 BSPT	43	19	14.5	24	0,063
1903-08-08	12	1/2"	3/4-16	1/2-14 BSPT	43.5	17	19	22	0,074
1903-08-10	14-16	5/8"	7/8-14	1/2-14 BSPT	48	19	19	24	0,077
1903-08-12	20	3/4"	1.1/16-12	1/2-14 BSPT	49	22	19	30	0,1
1903-12-10	14-16	5/8"	7/8-14	3/4-14 BSPT	49.5	19	19	27	0,12
1903-12-12	20	3/4"	1.1/16-12	3/4-14 BSPT	52.5	22	19	30	0,12
1903-12-16	25	1"	1.5/16-12	3/4-14 BSPT	53	23	19	36	0,15
1903-16-12	20	3/4"	1.1/16-12	1-11 BSPT	56	22	24	36	0,175
1903-16-16	25	1"	1.5/16-12	1-11 BSPT	58.5	23	24	36	0,19
1903-20-20	32	1.1/4"	1.5/8-12	1.1/4-11 BSPT	60.5	24	24.5	46	0,315
1903-24-24	38	1.1/2"	1.7/8-12	1.1/2-11 BSPT	66	27.5	25.5	50	0,43

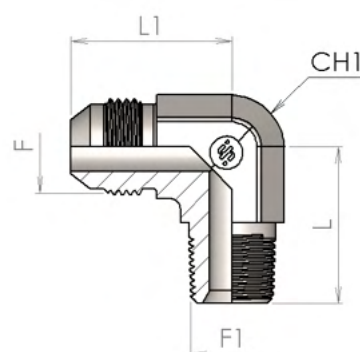
**Terminale a 90° M/M
JIC-BSPT**
SDE

Part number	Dimensions							Weight kg/unit
	Ø		F	F1	L	L1	CH1	
	tube mm	tube inch						
5165-02-04	6	1/4"	7/16-20	1/8-28 BSPT	23	24	14	0,02
5165-02-05	8	5/16"	1/2-20	1/8-28 BSPT	23.5	24	14	0,029
5165-04-04	6	1/4"	7/16-20	1/4-19 BSPT	27.5	23	14	0,042
5165-04-05	8	5/16"	1/2-20	1/4-19 BSPT	27.5	24	14	0,042
5165-04-06	10	3/8"	9/16-18	1/4-19 BSPT	27.5	27	14	0,045
5165-06-06	10	3/8"	9/16-18	3/8-19 BSPT	32	29	19	0,076
5165-06-08	12	1/2"	3/4-16	3/8-19 BSPT	32	31	19	0,086
5165-08-06	10	3/8"	9/16-18	1/2-14 BSPT	36	31.5	22	0,117
5165-08-08	12	1/2"	3/4-16	1/2-14 BSPT	36	33.5	22	0,125
5165-08-10	14-16	5/8"	7/8-14	1/2-14 BSPT	36	36	22	0,129
5165-12-12	18-20	3/4"	1.1/16-12	3/4-14 BSPT	42.5	42	27	0,198
5165-16-16	25	1"	1.5/16-12	1-11 BSPT	50	46	33	0,328

5265

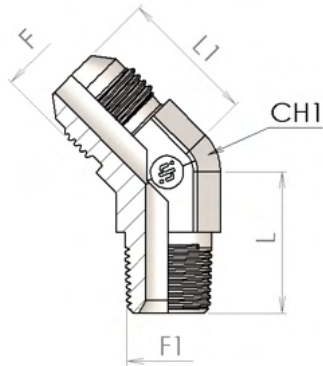

Terminale a 45° M/M JIC-BSPT

SDE45

Part number	Dimensions							Weight kg/unit
	Ø		F	F1	L	L1	CH1	
	tube mm	tube inch						
5265-02-04	6	1/4"	7/16-20	1/8-28 BSPT	16.5	18.5	12	0,02
5265-02-05	8	5/16"	1/2-20	1/8-28 BSPT	16.5	19.5	14	0,025
5265-04-04	6	1/4"	7/16-20	1/4-19 BSPT	22	21	14	0,03
5265-04-05	8	5/16"	1/2-20	1/4-19 BSPT	22	21	14	0,03
5265-04-06	10	3/8"	9/16-18	1/4-19 BSPT	22	21	14	0,027
5265-06-06	10	3/8"	9/16-18	3/8-19 BSPT	24	22	19	0,052
5265-06-08	12	1/2"	3/4-16	3/8-19 BSPT	24	25	19	0,06
5265-08-08	12	1/2"	3/4-16	1/2-14 BSPT	29.5	25	22	0,092
5265-08-10	14-16	5/8"	7/8-14	1/2-14 BSPT	29.5	28	22	0,092
5265-12-12	18-20	3/4"	1.1/16-12	3/4-14 BSPT	30.5	32.5	27	0,15
5265-16-16	25	1"	1.5/16-12	1-11 BSPT	37.5	37	33	0,24

Terminale a T laterale M/M JIC-BSPT

SDRT

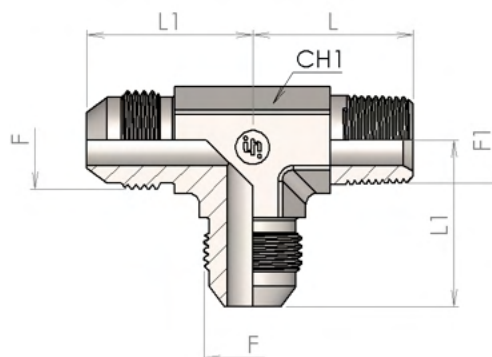

Part number	Dimensions							Weight kg/unit
	Ø		F	F1	L	L1	CH1	
	tube mm	tube inch						
5275-02-04	6	1/4"	7/16-20	1/8-28 BSPT	19.5	22	12	0,03
5275-02-05	8	5/16"	1/2-20	1/8-28 BSPT	23.5	24	14	0,039
5275-04-04	6	1/4"	7/16-20	1/4-19 BSPT	27.5	23	14	0,052
5275-04-05	8	5/16"	1/2-20	1/4-19 BSPT	27.5	24	14	0,053
5275-04-06	10	3/8"	9/16-18	1/4-19 BSPT	27.5	27	14	0,055
5275-04-08	12	1/2"	3/4-16	1/4-19 BSPT	29.5	31	19	0,066
5275-06-06	10	3/8"	9/16-18	3/8-19 BSPT	32	29	19	0,077
5275-06-08	12	1/2"	3/4-16	3/8-19 BSPT	32	31	19	0,111
5275-06-10	14-16	5/8"	7/8-14	3/8-19 BSPT	34	36	22	0,138
5275-08-08	12	1/2"	3/4-16	1/2-14 BSPT	36	33.5	22	0.163
5275-08-10	14-16	5/8"	7/8-14	1/2-14 BSPT	36	36	22	0,169
5275-08-12	18-20	3/4"	1.1/16-12	1/2-14 BSPT	39	42	27	0,211
5275-12-10	14-16	5/8"	7/8-14	3/4-14 BSPT	42.5	39	27	0,245
5275-12-12	18-20	3/4"	1.1/16-12	3/4-14 BSPT	42.5	42	27	0,267
5275-12-16	25	1"	1.5/16-12	3/4-14 BSPT	46	46	33	0,311
5275-16-12	18-20	3/4"	1.1/16-12	1-11 BSPT	50	44	33	0,36
5275-16-16	25	1"	1.5/16-12	1-11 BSPT	50	46	33	0,407
5275-16-20	30-32	1.1/4"	1.5/8-12	1-11 BSPT	55	52	41	0,522
5275-20-20	30-32	1.1/4"	1.5/8-12	1.1/4-11 BSPT	60.5	52	41	0,681
5275-24-24	38	1.1/2"	1.7/8-12	1.1/2-11 BSPT	67	59	50	0,905

5280

Terminale a T centrale M/M JIC-BSPT

SDBT

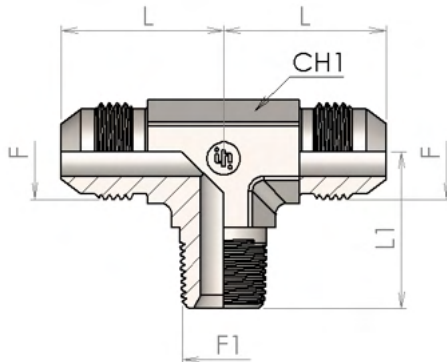

Part number	Dimensions							Weight kg/unit
	Ø		F	F1	L	L1	CH1	
	tube mm	tube inch						
5280-02-04	6	1/4"	7/16-20	1/8-28 BSPT	19.5	22	12	0,03
5280-02-05	8	5/16"	1/2-20	1/8-28 BSPT	23.5	24	14	0,039
5280-04-04	6	1/4"	7/16-20	1/4-19 BSPT	27.5	23	14	0,052
5280-04-06	10	3/8"	9/16-18	1/4-19 BSPT	27.5	27	14	0,055
5280-06-06	10	3/8"	9/16-18	3/8-19 BSPT	32	29	19	0,077
5280-06-08	12	1/2"	3/4-16	3/8-19 BSPT	32	31	19	0,111
5280-08-08	12	1/2"	3/4-16	1/2-14 BSPT	36	33.5	22	0,163
5280-08-10	14-16	5/8"	7/8-14	1/2-14 BSPT	36	36	22	0,169
5280-12-12	18-20	3/4"	1.1/16-12	3/4-14 BSPT	42.5	42	27	0,267
5280-16-16	25	1"	1.5/16-12	1-11 BSPT	50	46	33	0,407

Tappo maschio SAE (ISO 11926-1)

PL

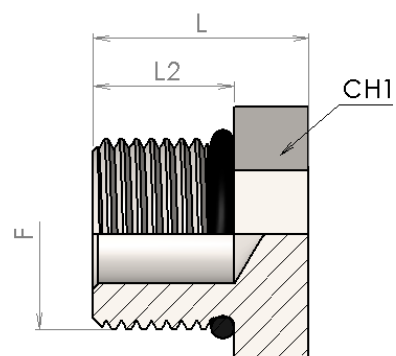

Part number	Dimensions				Weight kg/unit
	F	L	L2	CH1	
5040-04	7/16-20	17	9	14	0,015
5040-05	1/2-20	17	9	14	0,017
5040-06	9/16-18	18.5	10	17	0,025
5040-08	3/4-16	20.5	11	22	0,045
5040-10	7/8-14	23.5	13	27	0,075
5040-12	1 1/16-12	28	15	32	0,125
5040-16	1 5/16-12	28.5	15	38	0,175

J605

Tappo maschio JIC (ISO 8434-2)

PL

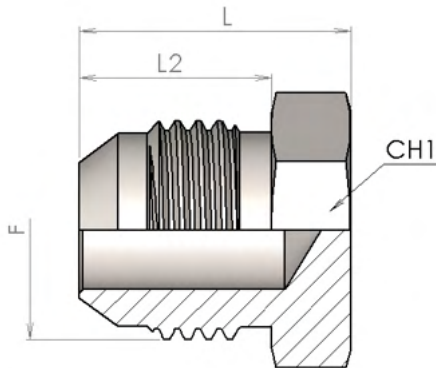

Part number	Dimensions						Weight kg/unit
	Ø		F	L	L2	CH1	
	tube mm	tube inch					
J605-04	6	1/4"	7/16-20	20.5	14	12	0,01
J605-05	8	5/16"	1/2-20	20.5	14	14	0,014
J605-06	10	3/8"	9/16-18	21.5	14	17	0,02
J605-08	12	1/2"	3/4-16	24	17	22	0,04
J605-10	14-16	5/8"	7/8-14	28	19	24	0,06
J605-12	18-20	3/4"	1 1/16-12	32.5	22	30	0,095
J605-16	25	1"	1 5/16-12	34	23	36	0,1
J605-20	30-32	1.1/4"	1 5/8-12	37	24	46	0,27
J605-24	38	1.1/2"	1 7/8-12	42	27.5	50	0,36
J605-32	50	2"	2 1/2-12	55	34	65	0,47

Tappo femmina JIC (ISO 8434-2)

PL

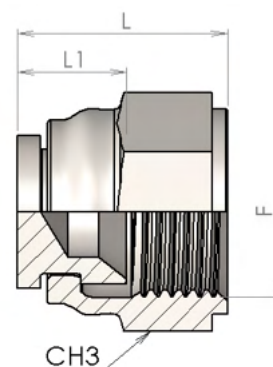

Part number	Dimensions						Weight kg/unit
	Ø		F	L	L1	CH3	
	tube mm	tube inch					
J608-04	6	1/4"	7/16-20	18.5	9.5	14	0,014
J608-05	8	5/16"	1/2-20	19.5	10	17	0,019
J608-06	10	3/8"	9/16-18	20.5	11.5	19	0,031
J608-08	12	1/2"	3/4-16	24	13.5	22	0,045
J608-10	16	5/8"	7/8-14	27.5	14.5	27	0,075
J608-12	20	3/4"	1 1/16-12	29.5	16	32	0,114
J608-16	32	1.1/4"	1 5/16-12	33	17	41	0,272
J608-20	38	1.1/2"	1 5/8-12	36.5	20.5	50	0,553
J608-24	50	2"	1 7/8-12	42	23	60	0,93

MJ

Terminale dritto maschio JIC a saldare con tasca (ISO 8434-2)

BRS

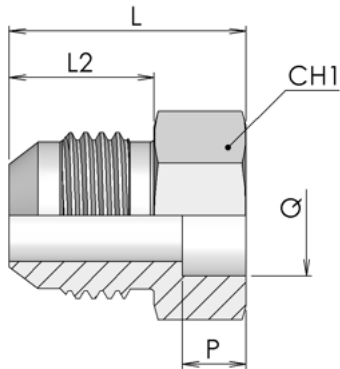

Part number	Dimensions								Weight kg/unit
	Ø		F	Q	P	L	L2	CH1	
	tube mm	tube inch							
MJ-05-10	8	5/16"	1/2-20	10	8.5	26	14	17	0,020
MJ-06-10	10	3/8"	9/16-18	10	8.5	27.5	14	19	0,034
MJ-06-12	10	3/8"	9/16-18	12	8.5	27.5	14	19	0,030
MJ-08-12	12	1/2"	3/4-16	12	8.5	29	17	22	0,047
MJ-10-16	14-16	5/8"	7/8-14	16	9	31.5	19	24	0,058
MJ-12-18	18-20	3/4"	1 1/16-12	18	12.5	40	22	30	0,118
MJ-12-20	18-20	3/4"	1 1/16-12	20	12.5	40	22	30	0,116
MJ-16-25	25	1"	1 5/16-12	25	14	42	23	36	0,161

Indice

5000	pag 6
5010	pag 7
1900	pag 8
5100	pag 9
5120	pag 10
5900	pag 11
5050	pag 12
5036	pag 13
5035	pag 14
5037	pag 15
5038	pag 16
5045	pag 17
5056	pag 18
5060	pag 19
5070	pag 20
5080	pag 21
5090	pag 22
5110	pag 23
5130	pag 24
J107	pag 25
1906	pag 26
5140	pag 27
5150	pag 28
5160	pag 29
5170	pag 30
5180	pag 31
1907	pag 32
5190	pag 33
5200	pag 34
5210	pag 35
5220	pag 36
5805	pag 37
1915	pag 38
1905	pag 39
5185	pag 40

Indice

5230	pag 41
5235	pag 42
5240	pag 43
5250	pag 44
1910	pag 45
5430	pag 46
5440	pag 47
5450	pag 48
5455	pag 49
1775	pag 50
1777	pag 51
5400	pag 52
5410	pag 53
5420	pag 54
5425	pag 55
1903	pag 56
5165	pag 57
5265	pag 58
5275	pag 59
5280	pag 60
5040	pag 61
J605	pag 62
J608	pag 63
MJ	pag 64

DIN

in!



7400



Nuts

6



7410



Cutting Rings

7



7430

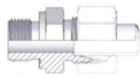

Stud Straight

8-12

7440

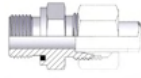

Stud connector for ports with elastomeric sealing (type E) and parell threads

13-15

7435

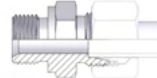

Stud Straight

16-17

7450

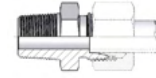

Stud Straight

18-20



7460

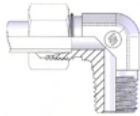

Stud Elbows

21-23



7500

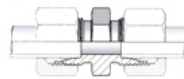

Straight union connector

24

7510

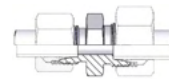

Straight reduced connector

25-26

7520



Elbow

27

7000

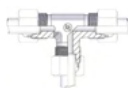

Tee

28

7010



Cross

29



7020



Bulkhead straight connector (BHS) and locknut (LN)

30

7130

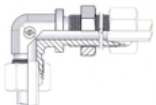

Bulkhead elbow (BHE) and locknut (LN)

31

M107



Locknut

32



7360



Swivel stud straight adapter with O-ring

33-34

7370

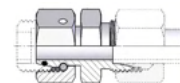

Reducing swivel straight adapter with O-ring

35-38

7380



Swivel with two O-ring straight

39

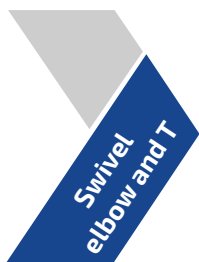

7330

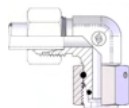

Swivel elbow with O-ring

40

7335

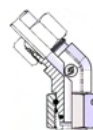

Swivel elbow 45° with O-ring

41

7350

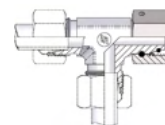

Swivel elbow with O-ring Run Tee

42

7340

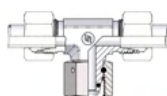

Swivel elbow with O-ring Branch Tee

43



7600

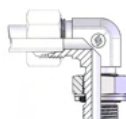

Stud Adjustable elbow

44-46

7605

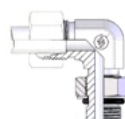

Stud Adjustable elbow

47

7630

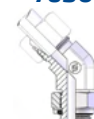

Stud Adjustable 45° elbow

48

7635

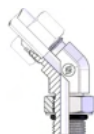

Stud Adjustable 45° elbow

49

7610

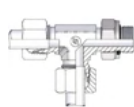

Stud Adjustable Run Tee

50-51

7615

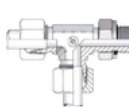

Stud Adjustable Run Tee

52

7620



Stud Adjustable Branch Tee

53-54

7625

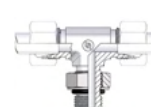

Stud Adjustable Branch Tee

55

7240



Stud straight

56-57



7250

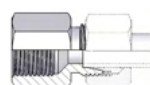

Straight

58-59



7030

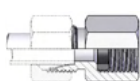

Straight Gauge couplings

60

7035

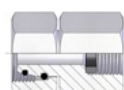

Swivel with O-ring Gauge Coupling

61



7260



Male Plug Elastomeric sealing

62-63

7270

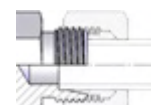

Male Plug

64

7290



Plug with O-ring

65



7420

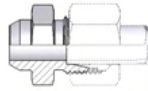

Weld-on straight connector

66

7120

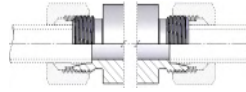

Weld-in bulkhead straight connector

67

7280

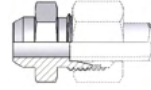

Weld-on nipple with O-ring

68

Dadi per Raccordi 24° (ISO 8434-1) N

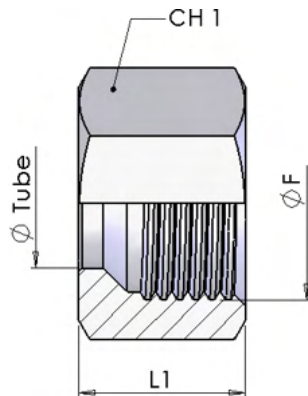

Type	W.P. bar	Part number	Dimensions				Weight kg/unit
			Thread			Ø	
			F	CH1	L1	tube mm	
LL	100	7400-04LLNI	M 8x1	10	11.0	4	0,004
		7400-06LLNI	M 10x1	12	11.5	6	0,006
		7400-08LLNI	M 12x1	14	12.0	8	0,007
L	315	7400-06LNI	M 12x1,5	14	14.5	6	0,010
		7400-08LNI	M 14x1,5	17	14.5	8	0,015
		7400-10LNI	M 16x1,5	19	15.5	10	0,018
		7400-12LNI	M 18x1,5	22	15.5	12	0,025
		7400-15LNI	M 22x1,5	27	17.0	15	0,042
		7400-18LNI	M 26x1,5	32	18.0	18	0,062
L	160	7400-22LNI	M 30x2	36	20.0	22	0,082
		7400-28LNI	M 36x2	41	21.0	28	0,089
		7400-35LNI	M 45x2	50	24.0	35	0,137
		7400-42LNI	M 52x2	60	24.0	42	0,216
S	630	7400-06SNI	M 14x1,5	17	16.5	6	0,017
		7400-08SNI	M 16x1,5	19	16.5	8	0,020
		7400-10SNI	M 18x1,5	22	17.5	10	0,031
		7400-12SNI	M 20x1,5	24	17.5	12	0,034
		7400-14SNI	M 22x1,5	27	20.5	14	0,053
S	400	7400-16SNI	M 24x1,5	30	20.5	16	0,066
		7400-20SNI	M 30x2	36	24.0	20	0,102
		7400-25SNI	M 36x2	46	27.0	25	0,202
S	250	7400-30SNI	M 42x2	50	29.0	30	0,219
		7400-38SNI	M 52x2	60	32.5	38	0,339

Anellino tagliente (ISO 8434-1) CR

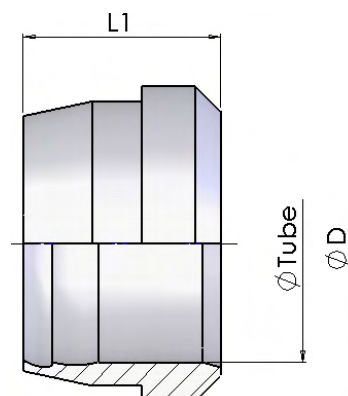

Type	W.P. bar	Part number	Dimensions			Weight kg/unit
			D	L1	Ø tube mm	
LL	100	7410-04LL	6	6.0	4	0,0003
		7410-06LL	8	7.0	6	0,0008
		7410-08LL	10	7.0	8	0,0010
LS	630	7410-06LS	10	9.5	6	0,0017
		7410-08LS	12	9.5	8	0,0022
		7410-10LS	14	10.0	10	0,0031
		7410-12LS	16	10.0	12	0,0035
L	250	7410-15L	19	10.0	15	0,0045
L	160	7410-18L	23	10.0	18	0,0055
		7410-22L	27	10.5	22	0,0077
L	100	7410-28L	33	11.0	28	0,0094
		7410-35L	41	13.0	35	0,0200
		7410-42L	48	13.0	42	0,0230
S	630	7410-14S	19	10.0	14	0,0390
S	400	7410-16S	21	10.5	16	0,0560
		7410-20S	26	12.0	20	0,0154
		7410-25S	32	12.0	25	0,0133
S	250	7410-30S	36	13.0	30	0,0193
		7410-38S	44	13.0	38	0,2250

Terminale diritto Filettatura: BSPB (Form B ISO 1179-4) SDS

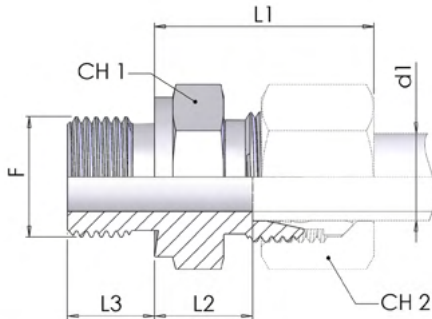

Type	W.P. bar	Part number	Dimensions						Ø tube mm	Weight kg/unit
			CH1	CH2	F	L1	L2	L3		
L	315	7430-06LR-1NI	14	14	G 1/8	23.0	8.5	8	6	0,014
		7430-06LR04-1NI	19	14	G 1/4	24.5	10	12	6	0,024
		7430-06LR06-1NI	22	14	G 3/8	26.0	11.5	12	6	0,040
		7430-08LR02-1NI	14	17	G 1/8	24.5	9.5	8	8	0,027
		7430-08LR-1NI	19	17	G 1/4	25.0	10	12	8	0,027
		7430-08LR06-1NI	22	17	G 3/8	26.5	11.5	12	8	0,044
		7430-08LR08-1NI	27	17	G 1/2	27.0	12	14	8	0,074
		7430-10LR-1NI	19	19	G 1/4	26.0	11	12	10	0,030
		7430-10LR06-1NI	22	19	G 3/8	27.5	12.5	12	10	0,045
		7430-10LR08-1NI	27	19	G 1/2	28.0	13	14	10	0,072
		7430-12LR04-1NI	19	22	G 1/4	26.5	12	12	12	0,032
		7430-12LR-1NI	22	22	G 3/8	27.0	12.5	12	12	0,042
		7430-12LR08-1NI	27	22	G 1/2	27.5	13	14	12	0,071
		7430-15LR06-1NI	24	27	G 3/8	28.5	13.5	12	15	0,052
		7430-15LR-1NI	27	27	G 1/2	29.0	14	14	15	0,071
		7430-15LR12-1NI	32	27	G 3/4	30.0	15	16	15	0,117
		7430-18LR-1NI	27	32	G 1/2	31.0	14.5	14	18	0,070
		7430-18LR12-1NI	32	32	G 3/4	31.0	14.5	16	18	0,110
L	160	7430-22LR08-1NI	32	36	G 1/2	33.0	16.5	14	22	0,088
		7430-22LR-1NI	32	36	G 3/4	33.0	16.5	16	22	0,103
		7430-28LR12-1NI	41	41	G 3/4	34.0	17.5	16	28	0,143
		7430-28LR-1NI	41	41	G 1	34.0	17.5	18	28	0,169
		7430-35LR-1NI	50	50	G 1 1/4	39.0	17.5	20	35	0,274
		7430-42LR-1NI	55	60	G 1 1/2	42.0	19	22	42	0,349

Terminale diritto Filettatura: BSPP (Form B ISO 1179-4) SDS

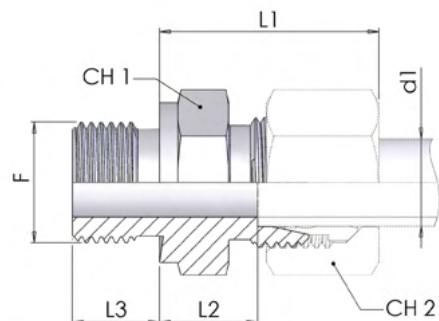

Type	W.P. bar	Part number	Dimensions						Weight kg/unit	
			CH1	CH2	F	L1	L2	L3		Ø tube mm
S	630	7430-06SR-1NI	19	17	G 1/4	28.0	13	12	6	0,035
		7430-06SR08-1NI	27	17	G 1/2	33.0	18	14	6	0,067
		7430-08SR-1NI	19	19	G 1/4	30.0	15	12	8	0,041
		7430-08SR06-1NI	22	19	G 3/8	30.5	15.5	12	8	0,055
		7430-10SR04-1NI	19	22	G 1/4	30.5	14.5	12	10	0,042
		7430-10SR-1NI	22	22	G 3/8	31.0	15	12	10	0,056
		7430-10SR08-1NI	27	22	G 1/2	33.5	17.5	14	10	0,078
		7430-12SR04-1NI	22	24	G 1/4	32.5	16.5	12	12	0,057
		7430-12SR-1NI	22	24	G 3/8	33.0	17	12	12	0,062
		7430-12SR08-1NI	27	24	G 1/2	33.5	17.5	14	12	0,097
		7430-14SR06-1NI	24	27	G 3/8	36.5	18.5	12	14	0,075
7430-14SR-1NI	27	27	G 1/2	37.0	19	14	14	0,098		
S	400	7430-16SR06-1NI	27	30	G 3/8	36.5	18	12	16	0,084
		7430-16SR-1NI	27	30	G 1/2	37.0	18.5	14	16	0,091
		7430-16SR12-1NI	32	30	G 3/4	39.0	20.5	16	16	0,155
		7430-20SR08-1NI	32	36	G 1/2	42.0	20.5	14	20	0,133
		7430-20SR-1NI	32	36	G 3/4	42.0	20.5	16	20	0,151
		7430-25SR12-1NI	41	46	G 3/4	47.0	23	16	25	0,241
		7430-25SR-1NI	41	46	G 1	47.0	23	18	25	0,266
		7430-30SR16-1NI	46	50	G 1	50.0	23.5	18	30	0,328
7430-30SR-1NI	50	50	G 1 1/4	50.0	23.5	20	30	0,417		
S	315	7430-38SR20-1NI	55	60	G 1 1/4	57.0	26	20	38	0,550
		7430-38SR-1NI	55	60	G 1 1/2	57.0	26	22	38	0,566

Terminale diritto Filettatura: Metrica (Form B ISO 9974-3) SDS

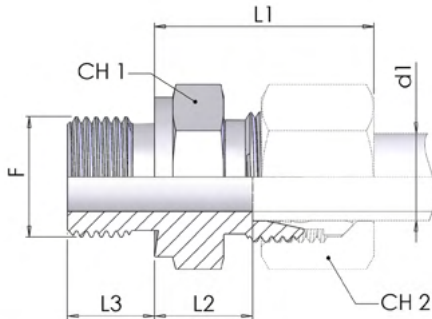

Type	W.P. bar	Part number	Dimensions						Ø tube mm	Weight kg/unit
			CH1	CH2	F	L1	L2	L3		
L	315	7430-06LM-1NI	14	14	M 10x1	23.0	8.5	8	6	0,014
		7430-08LM-1NI	17	17	M 12x1,5	25.0	10	12	8	0,022
		7430-08LM14-1NI	19	17	M 14x1,5	26.0	10	12	8	0,029
		7430-08LM18-1NI	24	17	M 18x1,5	26.5	11.5	12	8	0,052
		7430-10LM-1NI	19	19	M 14x1,5	26.0	11	12	10	0,030
		7430-10LM16-1NI	22	19	M 16x1,5	27.5	12.5	12	10	0,042
		7430-10LM18-1NI	24	19	M 18x1,5	27.5	12.5	12	10	0,052
		7430-10LM22-1NI	27	19	M 22x1,5	29.0	14	14	10	0,081
		7430-12LM-1NI	22	22	M 16x1,5	27.0	12.5	12	12	0,040
		7430-12LM18-1NI	24	22	M 18x1,5	27.0	12.5	12	12	0,045
		7430-12LM22-1NI	27	22	M 22x1,5	28.5	14	14	12	0,078
		7430-15LM-1NI	24	27	M 18x1,5	29.0	12	13.5	15	0,051
		7430-15LM22-1NI	27	27	M 22x1,5	30.0	15	14	15	0,078
		7430-18LM-1NI	27	32	M 22x1,5	31.0	14.5	14	18	0,077
7430-18LM18-1NI	27	32	M 18x1,5	30.5	14	12	18	0,066		
L	160	7430-22LM-1NI	32	36	M 26x1,5	33.0	16.5	16	22	0,101
		7430-28LM-1NI	41	41	M 33x2	34.0	17.5	18	28	0,167
		7430-35LM-1NI	50	50	M 42x2	39.0	17.5	20	35	0,278
		7430-42LM-1NI	55	60	M 48x2	42.0	19	22	42	0,354
S	630	7430-06SM-1NI	17	17	M 12x1,5	28.0	13	12	6	0,031
		7430-08SM-1NI	19	19	M 14x1,5	30.0	15	12	8	0,043
		7430-10SM-1NI	22	22	M 16x1,5	31.0	15	12	10	0,054
		7430-12SM-1NI	24	24	M 18x1,5	33.0	17	12	12	0,071
		7430-14SM-1NI	27	27	M 20x1,5	37.0	19	14	14	0,092
S	400	7430-16SM-1NI	27	30	M 22x1,5	37.0	18.5	14	16	0,097
		7430-20SM-1NI	32	36	M 27x2	42.0	20.5	16	20	0,153
		7430-25SM-1NI	41	46	M 33x2	47.0	23	18	25	0,266
S	315	7430-30SM-1NI	50	50	M 42x2	50.0	23.5	20	30	0,428
		7430-38SM-1NI	55	60	M 48x2	57.0	26	22	38	0,573

Terminale diritto Filettatura: Metrica (Form F ISO 6149-2/3)

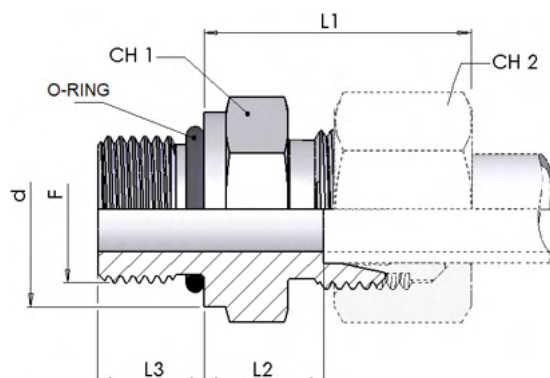

Type	W.P. bar	Part number	Dimensions						Ø tube mm	Weight kg/unit
			CH1	CH2	F	L1	L2	L3		
L	315	7430-06LI-1NI	14	14	M 10x1	23.0	8.5	8	6	0,015
		7430-08LI-1NI	17	17	M 12x1,5	25.0	10	12	8	0,022
		7430-10LI-1NI	19	19	M 14x1,5	26.0	11	12	10	0,029
		7430-12LI-1NI	22	22	M 16x1,5	27.0	12.5	12	12	0,040
		7430-15LI-1NI	24	27	M 18x1,5	29.0	14	14	15	0,052
		7430-18LI-1NI	27	32	M 22x1,5	31.0	14.5	14	18	0,077
L	160	7430-22LI-1NI	32	36	M 27x2	33.0	16.5	16	22	0,105
		7430-28LI-1NI	41	41	M 33x2	34.0	17.5	18	28	0,164
		7430-35LI-1NI	50	50	M 42x2	39.0	17.5	20	35	0,265
		7430-42LI-1NI	55	60	M 48x2	42.0	19	22	42	0,330
S	630	7430-06SI-1NI	17	17	M 12x1,5	28.0	13	12	6	0,029
		7430-08SI-1NI	19	19	M 14x1,5	30.0	15	12	8	0,041
		7430-10SI-1NI	22	22	M 16x1,5	31.0	15	12	10	0,055
		7430-12SI-1NI	24	24	M 18x1,5	33.0	17	12	12	0,075
S	400	7430-16SI-1NI	27	30	M 22x1,5	37.0	18.5	14	16	0,099
		7430-20SI-1NI	32	36	M 27x2	42.0	20.5	16	20	0,164
		7430-25SI-1NI	41	46	M 33x2	47.0	23	18	25	0,269
S	250	7430-30SI-1NI	50	50	M 42x2	50.0	23.5	20	30	0,493
		7430-38SI-1NI	55	60	M 48x2	57.0	26	22	38	0,571

Terminale diritto Filettatura: UNF (ISO 11926-2/3)

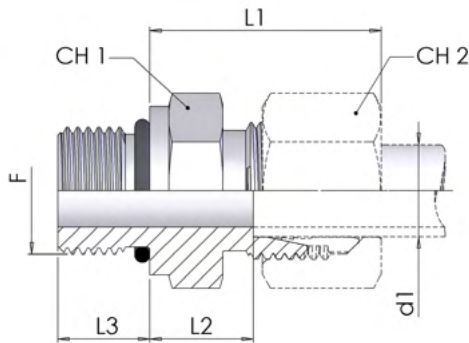

Type	W.P. bar	Part number	Dimensions						Ø tube mm	Weight kg/unit
			CH1	CH2	F	L1	L2	L3		
L	315	7430-08LU04-1NI	14	17	7/16-20 UNF	25.0	10	9	8	0,021
		7430-10LU04-1NI	17	19	7/16-20 UNF	26.0	11	9	10	0,024
		7430-12LU06-1NI	19	22	9/16-18 UNF	25.5	11	10	12	0,032
		7430-12LU08-1NI	22	22	3/4-16 UNF	27.5	13	11	12	0,045
L	400	7430-12LU10-1NI	27	22	7/8-14 UNF	29.3	12.8	12.7	12	0,07
L	315	7430-15LU08-1NI	27	27	3/4-16 UNF	29.0	14	11	15	0,054
		7430-15LU10-1NI	27	27	7/8-14 UNF	29.0	14	11	15	0,075
		7430-18LU08-1NI	27	32	3/4-16 UNF	31.0	14.5	11	18	0,066
		7430-18LU10-1NI	27	32	7/8-14 UNF	31.5	15	12.5	18	0,074
L	160	7430-22LU10-1NI	32	36	7/8-14 UNF	33.5	17	12.5	22	0,098
		7430-22LU12-1NI	32	36	1 1/16-12 UN	33.0	16.5	15	22	0,102
L	250	7430-22LU16-1NI	41	36	1 5/16-12 UN	34.0	16.5	15	22	0,175
L	160	7430-28LU12-1NI	41	41	1 1/16-12 UN	34.0	17.5	15	28	0,143
		7430-28LU16-1NI	41	41	1 5/16-12 UN	34.0	17.5	15	28	0,162
		7430-35LU16-1NI	46	50	1 5/16-12 UN	39.0	17.5	15	35	0,211
		7430-35LU20-1NI	50	50	1 5/8-12 UN	39.0	17.5	15	35	0,249
		7430-42LU20-1NI	55	60	1 5/8-12 UN	42.0	19	15	42	0,308
S	630	7430-08SU04-1NI	17	19	7/16-20 UNF	29.0	14.8	9.2	8	0,035
		7430-10SU06-1NI	19	22	9/16-18 UNF	31.0	15	10	10	0,041
		7430-12SU08-1NI	22	24	3/4-16 UNF	33.5	17.5	11	12	0,074
S	400	7430-16SU08-1NI	27	30	3/4-16 UNF	34.0	15.5	11	16	0,081
		7430-16SU10-1NI	27	30	7/8-14 UNF	37.5	19	12.5	16	0,087
		7430-20SU08-1NI	32	36	3/4-16 UNF	42.0	20.5	11	20	0,127
		7430-20SU10-1NI	32	36	7/8-14 UNF	42.5	21	12.5	20	0,138
		7430-20SU12-1NI	32	36	1 1/16-12 UN	42.0	20.5	15	20	0,150
		7430-25SU12-1NI	41	46	1 1/16-12 UN	47.0	23	15	25	0,24
		7430-25SU16-1NI	41	46	1 5/16-12 UN	47.0	23	15	25	0,257
S	250	7430-30SU16-1NI	46	50	1 5/16-12 UN	50.0	23.5	15	30	0,31
		7430-30SU20-1NI	50	20	1 5/8-12 UN	50.0	23.5	15	30	0,381

Terminale diritto Filettatura: BSPP Form E ISO 1179-2)

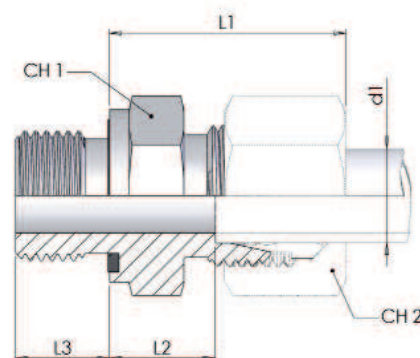

Type	W.P. bar	Part number	Dimensions						Ø tube mm	Weight kg/unit
			CH1	CH2	F	L1	L2	L3		
L	315	7440-06LR-1NI	14	14	G 1/8	23.0	8.5	8	6	0,013
		7440-06LR04-1NI	19	14	G 1/4	24.5	10	12	6	0,027
		7440-06LR06-1NI	22	14	G 3/8	26.0	11.5	12	6	0,038
		7440-08LR02-1NI	14	17	G 1/8	24.5	9.5	8	8	0,015
		7440-08LR-1NI	19	17	G 1/4	25.0	10	12	8	0,027
		7440-08LR06-1NI	22	17	G 3/8	26.5	11.5	12	8	0,044
		7440-08LR08-1NI	27	17	G 1/2	27.0	12	14	8	0,072
		7440-10LR02-1NI	17	19	G 1/8	25.5	110.5	8	10	0,020
		7440-10LR-1NI	19	19	G 1/4	26.0	11	12	10	0,029
		7440-10LR06-1NI	22	19	G 3/8	27.5	12.5	12	10	0,042
		7440-10LR08-1NI	27	19	G 1/2	28.0	13	14	10	0,063
		7440-12LR04-1NI	19	22	G 1/4	26.5	12	12	12	0,032
		7440-12LR-1NI	22	22	G 3/8	27.0	12.5	12	12	0,042
		7440-12LR08-1NI	27	22	G 1/2	27.5	13	14	12	0,067
		7440-15LR06-1NI	24	27	G 3/8	28.5	13.5	12	15	0,051
		7440-15LR-1NI	27	27	G 1/2	29.0	14	14	15	0,071
		7440-15LR12-1NI	32	27	G 3/4	30.0	15	16	15	0,117
		L	160	7440-18LR06-1NI	27	32	G 3/8	30.5	14	12
7440-18LR-1NI	27			32	G 1/2	31.0	14.5	14	18	0,070
7440-18LR12-1NI	32			32	G 3/4	31.0	14.5	16	18	0,109
7440-22LR08-1NI	32			36	G 1/2	33.0	16.5	14	22	0,087
7440-22LR-1NI	32			36	G 3/4	33.0	16.5	16	22	0,102
L	160	7440-22LR16-1NI	41	36	G 1	34.0	17.5	18	22	0,184
		7440-28LR12-1NI	41	41	G 3/4	34.0	17.5	16	28	0,146
L	250	7440-28LR-1NI	41	41	G 1	34.0	17.5	18	28	0,165
		7440-28LR20-1NI	50	46	G 1 1/4	34.0	18.5	20	28	0,255
L	160	7440-35LR16-1NI	46	50	G 1	39.0	17.5	18	35	0,238
		7440-35LR-1NI	50	50	G 1 1/4	39.0	17.5	20	35	0,271
		7440-42LR20-1NI	55	60	G 1 1/4	42.0	19	20	42	0,336

Terminale diritto Filettatura: BSPP (Form E ISO 1179-2)

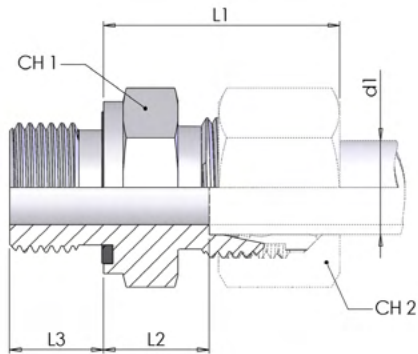

Type	W.P. bar	Part number	Dimensions							Weight kg/unit
			CH1	CH2	F	L1	L2	L3	Ø tube mm	
L	160	7440-42LR-1NI	55	60	G 1 1/2	42.0	19	22	42	0,500
S	630	7440-06SR-1NI	19	17	G 1/4	28.0	13	12	6	0,035
		7440-08SR-1NI	19	19	G 1/4	30.0	15	12	8	0,041
		7440-08SR06-1NI	22	19	G 3/8	30.5	15.5	12	8	0,057
		7440-10SR04-1NI	19	22	G 1/4	30.5	14.5	12	10	0,042
		7440-10SR-1NI	22	22	G 3/8	31.0	15	12	10	0,055
		7440-10SR08-1NI	27	22	G 1/2	33.5	17.5	14	10	0,089
		7440-12SR04-1NI	22	24	G 1/4	32.5	16.5	12	12	0,056
		7440-12SR-1NI	22	24	G 3/8	33.0	17	12	12	0,062
		7440-12SR08-1NI	27	24	G 1/2	33.5	17.5	14	12	0,091
		7440-14SR06-1NI	24	27	G 3/8	36.5	18.5	12	14	0,083
		7440-14SR-1NI	27	27	G 1/2	37.0	19	14	14	0,096
		7440-16SR06-1NI	27	30	G 3/8	36.5	18	12	16	0,081
		7440-16SR-1NI	27	30	G 1/2	37.0	18.5	14	16	0,092
		S	400	7440-16SR12-1NI	32	30	G 3/4	39.0	20.5	16
7440-20SR08-1NI	32			36	G 1/2	42.0	20.5	14	20	0,135
7440-20SR-1NI	32			36	G 3/4	42.0	20.5	16	20	0,149
7440-20SR16-1NI	41			36	G 1	42.0	22.5	18	20	0,250
7440-25SR12-1NI	41			46	G 3/4	47.0	23	16	25	0,237
7440-25SR-1NI	41			46	G 1	44.0	22.5	18	25	0,263
7440-25SR20-1NI	50			46	G 1 1/4	47.0	23	20	25	0,265
7440-30SR16-1NI	46			520	G 1	50.2	15.5	18	30	0,330
7440-30SR-1NI	50			50	G 1 1/4	50.0	23.5	20	30	0,419
7440-30SR24-1NI	55			50	G 1 1/2	53.0	26.5	22	30	0,64
L	400	7440-38SR16-1NI	55	60	G 1	57.0	26	18	38	0,45
S	315	7440-38SR20-1NI	55	60	G 1 1/4	57.0	26	20	38	0,555
		7440-38SR-1NI	55	60	G 1 1/2	57.0	26	22	38	0,559

Terminale diritto Filettatura: Metrica (Form E ISO 9974-2) SDS

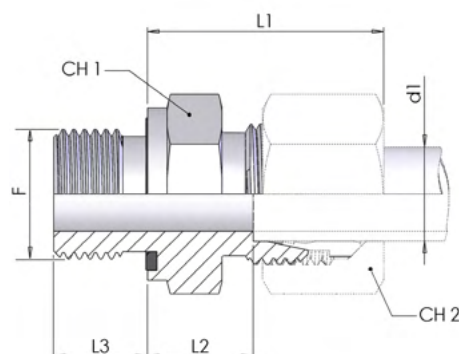

Type	W.P. bar	Part number	Dimensions						Ø tube mm	Weight kg/unit
			CH1	CH2	F	L1	L2	L3		
L	315	7440-06LM-1NI	14	14	M 10x1	23.0	8.5	8	6	0,014
		7440-08LM-1NI	17	17	M 12x1,5	25.0	10	12	8	0,021
		7440-10LM-1NI	19	19	M 14x1,5	26.0	11	12	10	0,029
		7440-10LM16-1NI	22	19	M 16x1,5	27.5	12.5	12	10	0,042
		7440-10LM18-1NI	24	19	M 18x1,5	27.5	12.5	12	10	0,049
		7440-10LM22-1NI	27	19	M 22x1,5	29.0	14	14	10	0,080
		7440-12LM14-1NI	19	22	M 14x1,5	27.0	12.5	12	12	0,029
		7440-12LM-1NI	22	22	M 16x1,5	27.0	12.5	12	12	0,039
		7440-12LM18-1NI	24	22	M 18x1,5	27.0	12.5	12	12	0,044
		7440-12LM22-1NI	27	22	M 22x1,5	28.5	14	14	12	0,064
		7440-15LM16-1NI	24	27	M 16x1,5	28.0	13	12	15	0,048
		7440-15LM-1NI	24	27	M 18x1,5	2.0	13.5	12	15	0,051
		7440-15LM22-1NI	27	27	M 22x1,5	30.0	15	14	15	0,071
		7440-18LM-1NI	27	32	M 18x1,5	30.5	14	12	18	0,065
		7440-18LM18-1NI	27	32	M 22x1,5	31.0	14.5	14	18	0,074
L	160	7440-22LM22-1NI	32	36	M 22x1,5	33.0	16.5	14	22	0,090
		7440-22LM-1NI	32	36	M 26x1,5	33.0	16.5	16	22	0,101
		7440-28LM-1NI	41	41	M 33x2	34.0	17.5	18	28	0,164
		7440-35LM-1NI	50	50	M 42x2	39.0	17.5	20	35	0,273
		7440-42LM-1NI	55	60	M 48x2	42.0	19	22	42	0,346
S	630	7440-06SM-1NI	17	17	M 12x1,5	28.0	13	12	6	0,029
		7440-08SM-1NI	19	19	M 14x1,5	30.0	15	12	8	0,041
		7440-10SM-1NI	22	22	M 16x1,5	31.0	15	12	10	0,053
		7440-12SM-1NI	24	24	M 18x1,5	33.0	17	12	12	0,071
		7440-14SM-1NI	27	27	M 20x1,5	37.0	19	14	14	0,094
		7440-16SM18-1NI	27	30	M 18x1,5	36.5	18	12	16	0,081
S	400	7440-16SM-1NI	27	30	M 22x1,5	37.0	18.5	14	16	0,096
		7440-20SM-1NI	32	36	M 27x2	42.0	20.5	16	20	0,151
		7440-25SM-1NI	41	46	M 33x2	47.0	23	18	25	0,265
S	315	7440-30SM-1NI	50	50	M 42x2	50.0	23.5	20	30	0,417
		7440-38SM-1NI	55	60	M 48x2	57.0	26	22	38	0,564

Terminale diritto Filettatura: BSPB (ISO 8434-6)

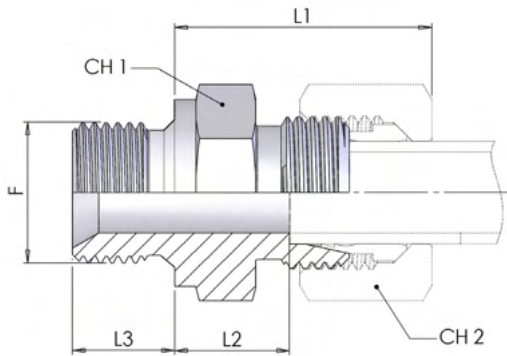

Type	W.P. bar	Part number	Dimensions						Ø tube mm	Weight kg/unit
			CH1	CH2	F	L1	L2	L3		
L	315	7435-06LR-1NI	14	14	G 1/8	23.0	8.5	8	6	0,014
		7435-06LR04-1NI	19	14	G 1/4	25.0	9	11	6	0,025
		7435-06LR06-1NI	22	14	G 3/8	26.0	11.5	12	6	0,042
		7435-08LR-1NI	19	17	G 1/4	25.0	10	11	8	0,027
		7435-10LR-1NI	19	19	G 1/4	26.0	11	11	10	0,027
		7435-10LR06-1NI	22	19	G 3/8	27.0	12.5	12	10	0,043
		7435-10LR08-1NI	27	19	G 1/2	28.0	13	14	10	0,068
		7435-12LR04-1NI	19	22	G 1/4	27.0	12	11	12	0,031
		7435-12LR-1NI	22	22	G 3/8	27.0	12.5	12	12	0,046
		7435-12LR08-1NI	27	22	G 1/2	28.0	13	14	12	0,067
		7435-15LR06-1NI	24	27	G 3/8	29.0	13.5	12	15	0,051
		7435-15LR-1NI	27	27	G 1/2	29.0	14	14	15	0,077
		7435-15LR12-1NI	32	27	G 3/4	30.0	15	16	15	0,112
		7435-18LR-1NI	27	32	G 1/2	31.0	14.5	14	18	0,071
7435-18LR12-1NI	32	32	G 3/4	30.0	14.5	16	18	0,106		
L	160	7435-22LR08-1NI	32	36	G 1/2	33.0	16.5	14	22	0,088
		7435-22LR-1NI	32	36	G 3/4	33.0	16.5	16	22	0,102
		7435-22LR16-1NI	41	36	G 1	34.0	16.5	19	22	0,167
		7435-28LR-1NI	41	41	G 1	34.0	17.5	19	28	0,167
		7435-35LR-1NI	50	50	G 1 1/4	39.0	17.5	20	35	0,272

**Terminale diritto Filettatura:
BSPP
(ISO 8434-6)**

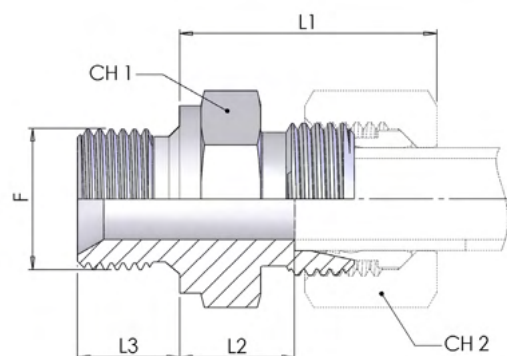

Type	W.P. bar	Part number	Dimensions							Ø tube mm	Weight kg/unit
			CH1	CH2	F	L1	L2	L3			
L	160	7435-42LR-1NI	55	60	G 1 1/2	42.0	19	22	42	0,345	
S	630	7435-06SR-1NI	19	17	G 1/4	28.0	13	11	6	0,034	
		7435-08SR-1NI	19	19	G 1/4	30.0	15	11	8	0,041	
		7435-10SR-1NI	22	22	G 3/8	31.0	15	12	10	0,055	
		7435-12SR-1NI	22	24	G 3/8	33.0	17	12	12	0,061	
		7435-12SR08-1NI	27	24	G 1/2	34.0	17.5	14	12	0,092	
		7435-14SR-1NI	27	27	G 1/2	37.0	19	14	14	0,094	
S	400	7435-16SR-1NI	27	30	G 1/2	37.0	18.5	14	16	0,090	
		7435-20SR-1NI	32	36	G 3/4	42.0	20.5	16	20	0,163	
		7435-25SR-1NI	41	46	G 1	47.0	23	18	25	0,257	
S	250	7435-30SR-1NI	50	50	G 1 1/4	50.0	23.5	20	30	0,403	
		7435-38SR-1NI	55	60	G 1 1/2	57.0	26	22	38	0,555	

Terminale diritto Filettatura: BSPT conica (Form C DIN 3852-2) SDS

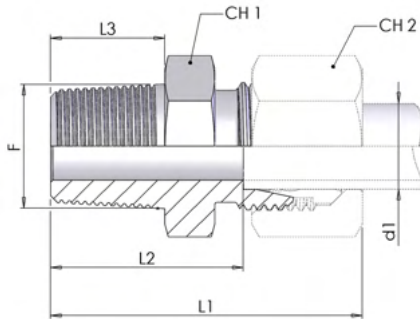

Tipo di tenuta: filettatura conica

Type	W.P. bar	Part number	Dimensions						Ø tube mm	Weight kg/unit
			Thread	CH1	CH2	L1	L2	L3		
			F							
LL	100	7450-04LLR-1NI	R 1/8 K	12	10	26.5	17	9	4	0,008
		7450-06LLR-1NI	R 1/8 K	12	12	26.5	15.5	9	6	0,009
		7450-08LLR-1NI	R 1/8 K	12	14	28.5	17.5	9	8	0,009
L	315	7450-06LR-1NI	R 1/8 K	12	14	30.0	16	9	6	0,012
		7450-06LR04-1NI	R 1/4 K	14	14	34.5	20	12	6	0,019
		7450-08LR-1NI	R 1/4 K	17	17	35.0	20	12	8	0,022
		7450-10LR-1NI	R 1/4 K	17	19	36.0	21	12	10	0,023
		7450-12LR04-1NI	R 1/4 K	19	22	36.5	22	12	12	0,028
		7450-12LR-1NI	R 3/8 K	19	22	36.5	22	12	12	0,033
		7450-12LR08-1NI	R 1/2 K	22	22	38.5	24	14	12	0,055
		7450-15LR-1NI	R 1/2 K	24	27	40.0	25	14	15	0,058
L	160	7450-18LR-1NI	R 1/2 K	27	32	42.0	25.5	14	18	0,064
		7450-22LR-1NI	R 3/4 K	32	36	46.0	29.5	16	22	0,096
		7450-28LR-1NI	R 1 K	41	41	49.0	32.5	18	28	0,156

Terminale diritto Filettatura: Metrica conica (Form C DIN 3852-1) SDS

Tipo di tenuta: filettatura conica

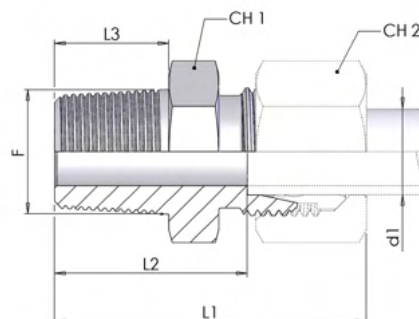

Type	W.P. bar	Part number	Dimensions							Weight kg/unit
			Thread						Ø	
			F	CH1	CH2	L1	L2	L3	tube mm	
LL	100	7450-04LLM-1NI	M 8x1K	12	10	26.5	16	8	4	0,006
		7450-06LLM-1NI	M 10x1K	12	12	26.5	14.5	8	6	0,008
		7450-08LLM-1NI	M 10x1K	12	14	28.5	16.5	8	8	0,010

Terminale diritto per tubo 24° Filettatura: NPTF conica SDS

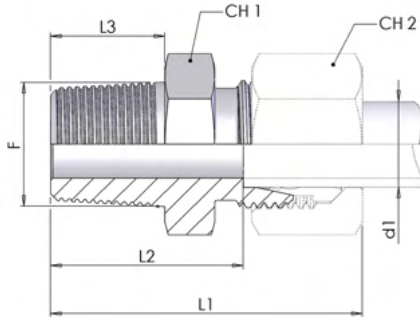

Tipo di tenuta: filettatura conica (ASME B1.20.1)

Type	W.P. bar	Part number	Dimensions						Weight kg/unit	
			Thread	CH1	CH2	L1	L2	L3		Ø tube mm
L	315	7450-06LN-1NI	1/8 NPTF	12	14	31.5	17	10	6	0,012
		7450-06LN04-1NI	1/4 NPTF	17	14	38.0	23	15	6	0,026
		7450-08LN-1NI	1/4 NPTF	17	17	38.0	23	15	8	0,025
		7450-10LN-1NI	1/4 NPTF	17	19	39.0	24	15	10	0,025
		7450-10LN06-1NI	3/8 NPTF	19	19	40.0	25	15	10	0,037
		7450-12LN04-1NI	1/4 NPTF	19	22	39.5	25	15	12	0,032
		7450-12LN-1NI	3/8 NPTF	19	22	39.5	25	15	12	0,036
		7450-12LN08-1NI	1/2 NPTF	22	22	44.5	30	19.5	12	0,064
		7450-15LN-1NI	1/2 NPTF	24	27	46.0	31	19.5	15	0,068
L	160	7450-18LN-1NI	1/2 NPTF	27	32	48.0	31.5	19.5	18	0,072
		7450-22LN-1NI	3/4 NPTF	32	36	50.0	33.5	20	22	0,101
		7450-28LN-1NI	1 NPTF	41	41	56.0	39.5	25	28	0,172
		7450-35LN-1NI	1 1/4 NPTF	46	50	62.0	40.5	25.5	35	0,256
S	630	7450-42LN-1NI	1 1/2 NPTF	55	60	65.0	42	26	42	0,352
		7450-06SN-1NI	1/4 NPTF	17	17	41.0	26	15	6	0,033
		7450-08SN-1NI	1/4 NPTF	17	19	43.0	28	15	8	0,038
		7450-10SN04-1NI	1/4 NPTF	19	22	44.0	25.5	13	10	0,043
		7450-10SN-1NI	3/8 NPTF	19	22	43.5	27.5	15	10	0,048
		7450-12SN04-1NI	1/4 NPTF	22	24	46.0	27.5	13	12	0,058
		7450-12SN-1NI	3/8 NPTF	22	24	45.5	29.5	15	12	0,062
		7450-12SN08-1NI	1/2 NPTF	22	24	50.5	34.5	19.5	12	0,090
S	400	7450-14SN-1NI	1/2 NPTF	24	27	54.0	36	19.5	14	0,099
		7450-16SN-1NI	1/2 NPTF	27	30	54.0	35.5	19.5	16	0,094
		7450-20SN-1NI	3/4 NPTF	32	36	59.0	37.5	20	20	0,149
		7450-25SN-1NI	1 NPTF	41	46	69.0	45	25	25	0,250
S	315	7450-30SN-1NI	1 1/4 NPTF	46	50	73.0	46.5	25.5	30	0,393
S	315	7450-38SN-1NI	1 1/2 NPTF	55	60	80.0	49	26	38	0,572

Terminale a 90° Filettatura: BSPT conica (Form C DIN 3852-2) SDE

Tipo di tenuta: filettatura conica

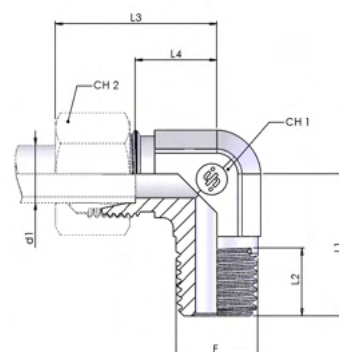

Type	W.P. bar	Part number	Dimensions							Ø tube mm	Weight kg/unit
			CH1	CH2	F	L1	L2	L3	L4		
L	315	7460-06LR-1NI	12	14	R 1/8 K	19.5	8	27	12	6	0,027
		7460-06LR04-1NI	12	14	R 1/4 K	27.5	12	29	14	6	0,035
		7460-08LR02-1NI	12	17	R 1/8 K	22.0	8	29	14	8	0,035
		7460-08LR-1NI	12	17	R 1/4 K	27.5	12	29	14	8	0,030
		7460-10LR-1NI	14	19	R 1/4 K	27.5	12	30	15	10	0,040
		7460-08LR06-1NI	14	17	R 3/8 K	28.0	12	31	16	8	0,055
		7460-10LR06-1NI	14	19	R 3/8 K	28.0	12	32	17	10	0,056
		7460-12LR04-1NI	17	22	R 1/4 K	29.0	12	32	17	12	0,070
		7460-12LR-1NI	17	22	R 3/8 K	29.5	12	32	17	12	0,072
		7460-12LR08-1NI	19	22	R 1/2 K	34.0	14	34	20	12	0,097
		7460-15LR06-1NI	19	27	R 3/8 K	30.0	12	36	21	15	0,09
		7460-15LR-1NI	19	27	R 1/2 K	36.0	14	36	21	15	0,095
L	160	7460-18LR-1NI	24	32	R 1/2 K	36.0	14	40	23.5	18	0,126
L	160	7460-22LR-1NI	27	36	R 3/4 K	40.5	17	44	27.5	22	0,212
S	630	7460-06SR-1NI	12	17	R 1/4 K	27.5	12	31	16	6	0,045
		7460-08SR-1NI	14	19	R 1/4 K	27.5	12	32	17	8	0,055
		7460-10SR-1NI	17	22	R 3/8 K	29.5	12	34	17.5	10	0,085
		7460-12SR-1NI	17	24	R 3/8 K	29.5	12	38	21.5	12	0,080
		7460-12SR08-1NI	19	24	R 1/2 K	36.0	14	37	20.5	12	0,105
		7460-14SR-1NI	19	27	R 1/2 K	36.0	14	40	22	14	0,105
S	400	7460-16SR-1NI	24	30	R 1/2 K	36.0	14	43	24.5	16	0,139
		7460-20SR-1NI	27	36	R 3/4 K	40.5	17	48	26.5	20	0,239

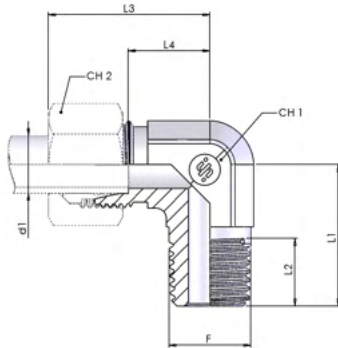

Terminale a 90° Filettatura: Metrica conica (Form C DIN 3852-1) SDE

Tipo di tenuta: filettatura conica

Type	W.P. bar	Part number	Dimensions							Ø tube mm	Weight kg/unit
			CH1	CH2	F	L1	L2	L3	L4		
L	315	7460-06LM-1NI	12	14	M 10x1,5 K	20.0	8	27	12	6	0,029
		7460-08LM-1NI	12	17	M 12x1,5 K	26.0	12	29	14	8	0,043
		7460-10LM-1NI	14	19	M 14x1,5 K	27.0	12	30	15	10	0,062
		7460-12LM-1NI	17	22	M 16x1,5 K	28.0	12	32	17	12	0,085
		7460-15LM-1NI	19	27	M 18x1,5 K	32.0	12	36	21	15	0,083
		7460-18LM-1NI	24	32	M 22x1,5 K	36.0	14	40	23.5	18	0,130
S	630	7460-06SM-1NI	12	17	M 12x1,5 K	26.0	12	31	16	6	0,052
		7460-08SM-1NI	14	19	M 14x1,5 K	27.0	12	32	17	8	0,074
		7460-10SM-1NI	17	22	M 16x1,5 K	28.0	12	34	17.5	10	0,090
		7460-12SM-1NI	17	24	M 18x1,5 K	28.0	12	38	21.5	12	0,100
		7460-14SM-1NI	19	27	M 20x1,5 K	32.0	14	40	22	14	0,104
S	400	7460-16SM-1NI	24	30	M 22x1,5 K	32.0	14	43	24.5	16	0,145

Terminale a 90° Filettatura: NPTF conica SDE

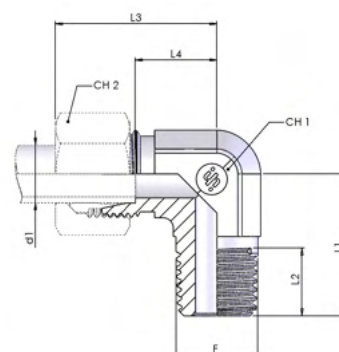

note: Tipo di tenuta: filettatura conica (ASME B1.20.1)

Type	W.P. bar	Part number	Dimensions							Ø tube mm	Weight kg/unit
			CH1	CH2	F	L1	L2	L3	L4		
L	315	7460-06LN-1NI	12	14	1/8 NPTF	20.0	10	27	12	6	0,030
		7460-06LN04-1NI	12	14	1/4 NPTF	26.0	15	29	14	6	0,035
		7460-08LN-1NI	12	17	1/4 NPTF	26.0	15	29	14	8	0,036
		7460-10LN-1NI	14	19	1/4 NPTF	27.0	15	30	15	10	0,049
		7460-12LN04-1NI	17	22	1/4 NPTF	28.0	15	32	17	12	0,071
		7460-12LN-1NI	17	22	3/8 NPTF	28.0	15	32	17	12	0,075
		7460-15LN-1NI	19	27	1/2 NPTF	34.0	19.5	36	21	15	0,090
		7460-18LN-1NI	24	32	1/2 NPTF	36.0	19.5	40	23.5	18	0,129
L	160	7460-22LN-1NI	27	36	3/4 NPTF	42.0	20	44	27.5	22	0,174
		7460-28LN-1NI	36	41	1 NPTF	48.0	25	47	30.6	28	0,285
S	630	7460-06SN-1NI	12	17	1/4 NPTF	26.0	15	31	16	6	0,046
		7460-08SN-1NI	14	19	1/4 NPTF	27.0	15	32	17	8	0,057
		7460-10SN-1NI	17	22	3/8 NPTF	28.0	15	34	17.5	10	0,075
		7460-12SN-1NI	17	24	3/8 NPTF	28.0	15	38	21.5	12	0,076
		7460-14SN-1NI	19	27	1/2 NPTF	34.0	19.5	40	22	14	0,104
S	400	7460-16SN-1NI	24	30	1/2 NPTF	36.0	19.5	43	24.5	16	0,146

Unione diritto (ISO 8434-1) S

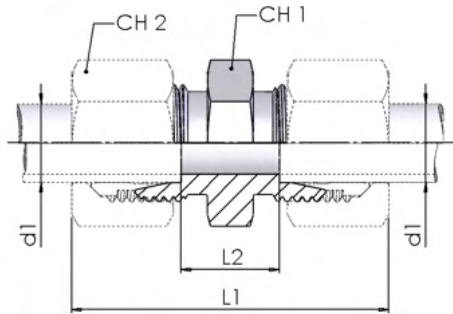

Type	W.P. bar	Part number	Dimensions				Ø tube mm	Weight kg/unit
			CH1	CH2	L1	L2		
LL	100	7500-04LL-1NI	12	10	31.0	12	4	0,005
		7500-06LL-1NI	12	11	32.0	9	6	0,007
		7500-08LL-1NI	12	14	35.0	12	8	0,010
L	315	7500-06L-1NI	12	14	39.0	10	6	0,012
		7500-08L-1NI	14	17	40.0	11	8	0,016
		7500-10L-1NI	17	19	42.0	13	10	0,022
		7500-12L-1NI	19	22	43.0	14	12	0,028
		7500-15L-1NI	24	27	46.0	16	15	0,049
		7500-18L-1NI	27	32	48.0	16	18	0,067
L	160	7500-22L-1NI	32	36	52.0	20	22	0,088
		7500-28L-1NI	41	41	54.0	21	28	0,136
		7500-35L-1NI	46	50	63.0	20	35	0,210
		7500-42L-1NI	55	60	66.0	21	42	0,294
S	630	7500-06S-1NI	14	17	45.0	16	6	0,025
		7500-08S-1NI	17	19	47.0	18	8	0,037
		7500-10S-1NI	19	22	49.0	17	10	0,043
		7500-12S-1NI	22	24	51.0	19	12	0,059
		7500-14S-1NI	24	27	57.0	22	14	0,075
S	400	7500-16S-1NI	27	30	57.0	21	16	0,087
		7500-20S-1NI	32	36	66.0	23	20	0,142
		7500-25S-1NI	41	46	74.0	26	25	0,250
S	250	7500-30S-1NI	46	50	80.0	27	30	0,323
		7500-38S-1NI	55	60	90.0	29	38	0,538

Unione diretto di riduzione (ISO 8434-1)

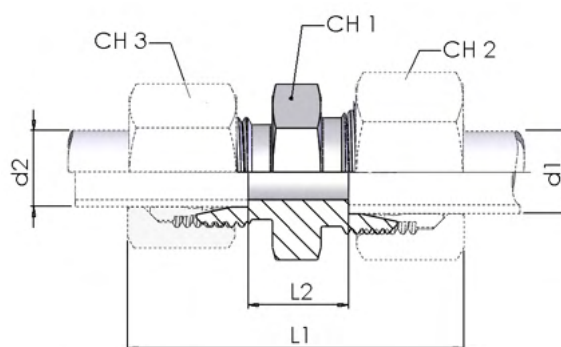

Type	W.P. bar	Part number	Dimensions						Weight kg/unit	
			CH1	CH2	CH3	L1	L2	Ø		
								tube d1 mm	tube d2 mm	
L	315	7510-08/06L-1NI	14	17	14	40.5	11	8	6	0,015
		7510-10/06L-1NI	17	19	14	41.5	12	10	6	0,020
		7510-10/08L-1NI	17	19	17	42.0	12	10	8	0,021
		7510-12/06L-1NI	19	22	14	42.0	13	12	6	0,025
		7510-12/08L-1NI	19	22	17	42.5	13	12	8	0,026
		7510-12/10L-1NI	19	22	19	43.5	14	12	10	0,027
		7510-15/10L-1NI	24	27	19	45.0	15	15	10	0,041
		7510-15/12L-1NI	24	27	22	44.5	15	15	12	0,042
		7510-18/10L-1NI	27	32	19	47.0	15.5	18	10	0,056
		7510-18/12L-1NI	27	32	22	46.5	15.5	18	12	0,057
L	160	7510-18/15L-1NI	27	32	27	48.0	16.5	18	15	0,061
		7510-22/12L-1NI	32	36	22	48.5	17.5	22	12	0,076
		7510-22/15L-1NI	32	36	27	50.0	18.5	22	15	0,081
		7510-22/18L-1NI	32	36	32	51.0	18	22	18	0,086
		7510-28/18L-1NI	41	41	32	52.0	19	28	18	0,123
		7510-28/22L-1NI	41	41	36	54.0	21	28	22	0,132
		7510-35/22L-1NI	46	50	36	59.0	21	35	22	0,190
S	630	7510-35/28L-1NI	46	50	41	59.0	21	35	28	0,190
		7510-08/06S-1NI	17	19	17	48.0	18	8	6	0,034
		7510-10/06S-1NI	19	22	17	48.5	17.5	10	6	0,040

7510

Unione diretto di riduzione (ISO 8434-1)

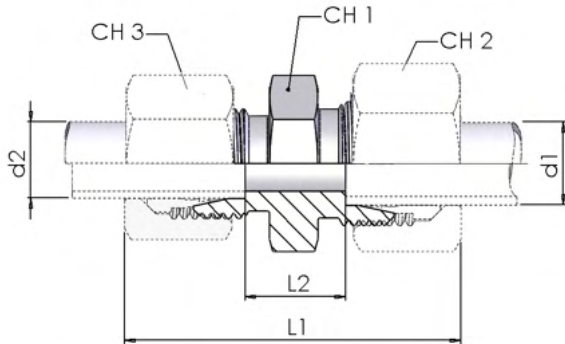

Type	W.P. bar	Part number	Dimensions						Weight kg/unit	
			CH1	CH2	CH3	L1	L2	Ø		
			CH1	CH2	CH3	L1	L2	tube d1 mm	tube d2 mm	
S	630	7510-10/08S-1NI	19	22	19	48.5	17.5	10	8	0,042
		7510-12/06S-1NI	22	24	17	50.5	19.5	12	6	0,054
		7510-12/08S-1NI	22	24	19	50.5	19.5	12	8	0,056
		7510-12/10S-1NI	22	24	22	51.0	19	12	10	0,058
		7510-14/10S-1NI	24	27	22	54.5	20.5	14	10	0,069
		7510-14/12S-1NI	24	27	24	54.5	20.5	14	12	0,070
S	400	7510-16/12S-1NI	27	30	24	54.5	20	16	12	0,080
		7510-16/14S-1NI	27	30	27	58.0	21.5	16	14	0,087
		7510-20/10S-1NI	32	36	22	59.5	22	20	10	0,122
		7510-20/12S-1NI	32	36	24	59.5	22	20	12	0,125
		7510-20/16S-1NI	32	36	30	63.0	23	20	16	0,129
		7510-25/16S-1NI	41	46	30	68.0	25.5	25	16	0,220
		7510-25/20S-1NI	41	46	36	71.0	25.5	25	20	0,232
		7510-30/20S-1NI	46	50	36	74.0	26	30	20	0,294
S	315	7510-30/25S-1NI	46	50	46	77.0	26.5	30	25	0,311
		7510-38/30S-1NI	55	60	50	87.0	29.5	38	30	0,488

Unione a 90° (ISO 8434-1) E

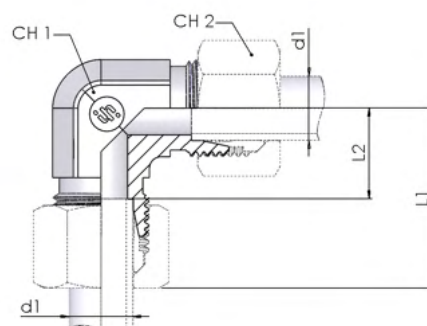

Type	W.P. bar	Part number	Dimensions					Weight kg/unit
			CH1	CH2	L1	L2	Ø tube mm	
L	315	7520-06L-1NI	12	14	27.0	12	6	0,028
		7520-08L-1NI	12	17	29.0	14	8	0,032
		7520-10L-1NI	14	19	30.0	15	10	0,041
		7520-12L-1NI	17	22	32.0	17	12	0,056
		7520-15L-1NI	19	27	36.0	21	15	0,074
		7520-18L-1NI	24	32	40.0	23.5	18	0,119
L	160	7520-22L-1NI	27	36	44.0	27.5	22	0,152
		7520-28L-1NI	36	41	47.0	30.5	28	0,251
		7520-35L-1NI	41	50	56.0	34.5	35	0,431
		7520-42L-1NI	50	60	63.0	40	42	0,782
S	630	7520-06S-1NI	12	17	31.0	16	6	0,035
		7520-08S-1NI	14	19	32.0	17	8	0,052
		7520-10S-1NI	17	22	34.0	17.5	10	0,072
		7520-12S-1NI	17	24	38.0	21.5	12	0,075
		7520-14S-1NI	19	27	40.0	22	14	0,104
S	400	7520-16S-1NI	24	30	43.0	24.5	16	0,127
		7520-20S-1NI	27	36	48.0	26.5	20	0,205
		7520-25S-1NI	36	46	54.0	30	25	0,349
		7520-30S-1NI	41	50	62.0	35.5	30	0,588
S	315	7520-38S-1NI	50	60	72.0	41	38	1,031

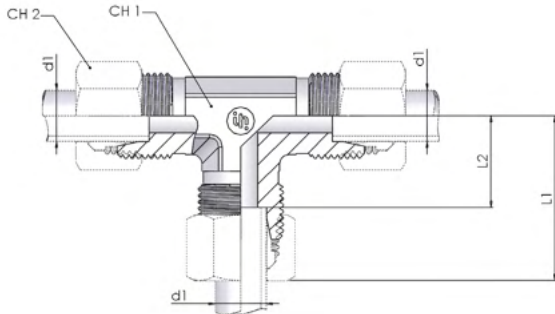

Type	W.P. bar	Part number	Dimensions				Ø tube mm	Weight kg/unit
			CH1	CH2	L1	L2		
L	315	7000-06L-1NI	12	14	27.0	12	6	0,037
		7000-08L-1NI	12	17	29.0	14	8	0,043
		7000-10L-1NI	14	19	30.0	15	10	0,048
		7000-12L-1NI	17	22	32.0	17	12	0,065
		7000-15L-1NI	19	27	36.0	21	15	0,106
		7000-18L-1NI	24	32	40.0	23.5	18	0,179
L	160	7000-22L-1NI	27	36	44.0	27.5	22	0,225
		7000-28L-1NI	36	41	47.0	30.5	28	0,396
		7000-35L-1NI	41	50	56.0	34.5	35	0,567
		7000-42L-1NI	50	60	63.0	40	42	0,905
S	630	7000-06S-1NI	12	17	31.0	16	6	0,068
		7000-08S-1NI	14	19	32.0	17	8	0,070
		7000-10S-1NI	17	22	34.0	17.5	10	0,091
		7000-12S-1NI	17	24	38.0	21.5	12	0,117
		7000-14S-1NI	19	27	40.0	22	14	0,136
S	400	7000-16S-1NI	24	24	16.0	43	16	0,202
		7000-20S-1NI	27	27	20.0	48	20	0,289
		7000-25S-1NI	36	36	25.0	54	25	0,545
		7000-30S-1NI	41	41	30.0	62	30	0,758
S	315	7000-38S-1NI	50	50	38.0	72	38	1,264

**Unione a croce
(ISO 8434-1)
K**

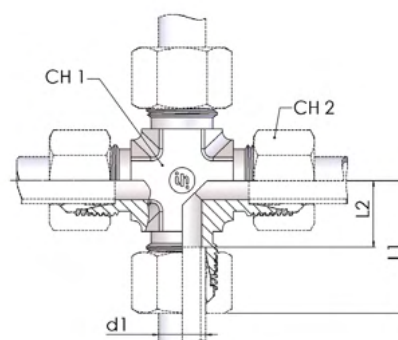

Type	W.P. bar	Part number	Dimensions					Weight kg/unit
			CH1	CH2	L1	L2	Ø tube mm	
L	315	7010-06L-1NI	14	14	27.0	12	6	0,039
		7010-08L-1NI	14	17	29.0	14	8	0,066
		7010-10L-1NI	14	19	30.0	15	10	0,072
		7010-12L-1NI	19	22	32.0	17	12	0,102
		7010-15L-1NI	19	27	36.0	21	15	0,127
		7010-18L-1NI	27	32	40.0	23.5	18	0,188
L	160	7010-22L-1NI	27	36	44.0	27.5	22	0,210
S	630	7010-06S-1NI	14	17	31.0	16	6	0,066
		7010-08S-1NI	14	19	32.0	17	8	0,081
		7010-10S-1NI	19	22	34.0	17.5	10	0,127
		7010-12S-1NI	19	24	38.0	21.5	12	0,169
S	400	7010-16S-1NI	27	30	43.0	24.5	16	0,260
		7010-20S-1NI	27	36	48.0	26.5	20	0,294

Passaparete Diritto (ISO 8434-1) BHSLN

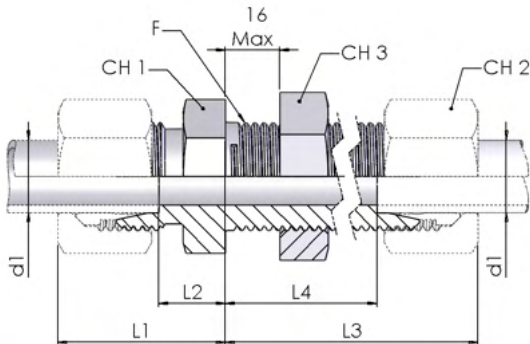

Type	W.P. bar	Part number	Dimensions								Ø tube mm	Weight kg/unit
			Thread F	CH1	CH2	CH3	L1	L2	L3	L4		
L	315	7020-06L-1NI	M 12x1,5	17	14	17	22.0	7	42	27	6	0,038
		7020-08L-1NI	M 14x1,5	19	17	19	23.0	8	42	27	8	0,049
		7020-10L-1NI	M 16x1,5	22	19	22	25.0	10	43	28	10	0,066
		7020-12L-1NI	M 18x1,5	24	22	24	25.0	10	44	29	12	0,076
		7020-15L-1NI	M 22x1,5	27	27	30	27.0	12	46	31	15	0,128
		7020-18L-1NI	M 26x1,5	32	32	36	30.0	13.5	49	32.5	18	0,199
L	160	7020-22L-1NI	M 30x2	36	36	41	33.0	16.5	51	34.5	22	0,248
		7020-28L-1NI	M 36x2	41	41	46	35.0	18.5	52	35.5	28	0,338
		7020-35L-1NI	M 45x2	50	50	55	40.0	18.5	58	36.5	35	0,539
		7020-42L-1NI	M 52x2	60	60	65	42.0	19	59	36	42	0,756
S	630	7020-06S-1NI	M 14x1,5	19	17	19	27.0	12	44	29	6	0,065
		7020-08S-1NI	M 16x1,5	22	19	22	28.0	13	44	29	8	0,087
		7020-10S-1NI	M 18x1,5	24	22	24	31.0	14.5	46	29.5	10	0,110
		7020-12S-1NI	M 20x1,5	27	24	27	31.0	14.5	47	30.5	12	0,139
		7020-14S-1NI	M 22x1,5	30	27	30	35.0	17	50	32	14	0,178
S	400	7020-16S-1NI	M 24x1,5	32	30	32	35.0	16.5	50	31.5	16	0,197
		7020-20S-1NI	M 30x2	41	36	41	39.0	17.5	55	33.5	20	0,345
		7020-25S-1NI	M 36x2	46	46	46	44.0	20	59	35	25	0,492
		7020-30S-1NI	M 42x2	50	50	50	48.0	21.5	64	37.5	30	0,617
S	315	7020-38S-1NI	M 52x2	65	60	65	53.0	22	68	30	38	1,080

Passaparete a 90° (ISO 8434-1) BHELN

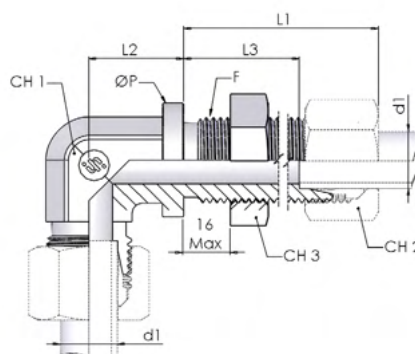

Type	W.P. bar	Part number	Dimensions								Weight kg/unit	
			Thread							Ø		
			F	CH1	CH2	CH3	L1	L2	L3	P	tube mm	
L	315	7130-06L-1NI	M 12x1,5	12	14	17	42.0	14	27	17	6	0,049
		7130-08L-1NI	M 14x1,5	12	17	19	42.0	17	27	19	8	0,061
		7130-10L-1NI	M 16x1,5	14	19	22	43.0	18	28	22	10	0,079
		7130-12L-1NI	M 18x1,5	17	22	24	44.0	20	29	24	12	0,096
		7130-15L-1NI	M 22x1,5	19	27	30	46.0	23	31	27	15	0,169
		7130-18L-1NI	M 26x1,5	24	32	36	49.0	24	32.5	32	18	0,255
L	160	7130-22L-1NI	M 30x2	27	36	41	51.0	30	34.5	36	22	0,318
		7130-28L-1NI	M 36x2	36	41	46	52.0	34	35.5	42	28	0,462
S	630	7130-06S-1NI	M 14x1,5	12	17	19	44.0	17	29	19	6	0,076
		7130-08S-1NI	M 16x1,5	14	19	22	44.0	18	29	22	8	0,102
		7130-10S-1NI	M 18x1,5	17	22	24	46.0	20	29.5	24	10	0,124
		7130-12S-1NI	M 20x1,5	17	24	27	47.0	21	30.5	27	12	0,160
		7130-14S-1NI	M 22x1,5	19	27	30	50.0	23	32	27	14	0,196
S	400	7130-16S-1NI	M 24x1,5	24	30	32	50.0	24	31.5	30	16	0,238
		7130-20S-1NI	M 30x2	27	36	41	55.0	30	33.5	36	20	0,399
		7130-25S-1NI	M 36x2	36	46	46	59.0	34	35	42	25	0,609

M107

Controdado per passaparete

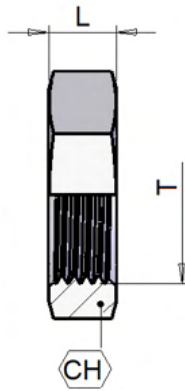

Part number	Dimensions			Weight kg/unit
	Thread			
	T	CH	L	
M107-12NI	M12x1,5	17	6	0,006
M107-14NI	M14x1,5	19	6	0,008
M107-16NI	M16x1,5	22	6	0,011
M107-18NI	M18x1,5	24	6	0,013
M107-20NI	M20x1,5	27	6	0,015
M107-22NI	M22x1,5	30	7	0,022
M107-24NI	M24x1,5	32	7	0,024
M107-26NI	M26x1,5	36	8	0,036
M107-30NI	M30x2	41	8	0,048
M107-36NI	M36x2	46	9	0,059
M107-42NI	M42x2	50	9	0,059
M107-45NI	M45x2	55	9	0,076
M107-52NI	M52x2	65	10	0,125

Raccordo diritto filettatura: BSPP (Form E ISO 1179-2)

DKO con guarnizione standard: FKM Guarnizione opzionale: NBR, EPDM

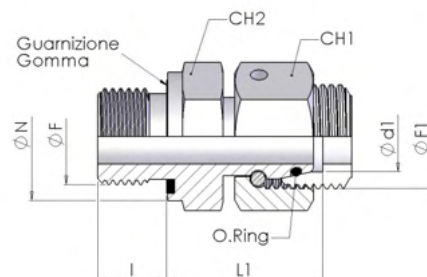

Type	W.P. bar	Part number	Dimensions								Weight kg/unit
			CH1	CH2	I	L1	F	F1	N	Ø tube D1 mm	
L	315	7360-06LRNI	14	14	8	24.5	1/8"	M12x1,5	14	6	0,026
		7360-08LRNI	17	19	12	29.5	1/4"	M14x1,5	19	8	0,057
		7360-10LRNI	19	19	12	27.5	1/4"	M16x1,5	19	10	0,056
L	400	7360-10LR06NI	19	22	12	28.0	3/8"	M16x1,5	22	10	0,07
L	315	7360-12LR04NI	19	19	12	27.5	1/4"	M18x1,5	19	12	0,069
		7360-12LRNI	22	22	12	34.0	3/8"	M18x1,5	22	12	0,096
		7360-12LR08NI	27	27	14	32.0	1/2"	M18x1,5	22	12	0,118
		7360-15LRNI	27	27	14	32.0	1/2"	M22x1,5	27	15	0,141
		7360-18LRNI	32	27	14	31.5	1/2"	M26x1,5	27	18	0,144
L	160	7360-22LRNI	36	32	16	32.5	3/4"	M30x2	32	22	0,201
		7360-28LRNI	41	41	18	35.0	1"	M36x2	40	28	0,293
		7360-35LRNI	50	50	20	42.5	1" 1/4	M45x2	50	35	0,509
		7360-42LRNI	60	55	22	46.5	1" 1/2	M52x2	55	42	0,722
S	630	7360-06SRNI	17	19	12	27.0	1/4"	M14x1,5	19	6	0,054
		7360-08SRNI	19	19	12	29.5	1/4"	M16x1,5	19	8	0,064
		7360-10SRNI	22	22	12	32.0	3/8"	M18x1,5	22	10	0,094
		7360-12SR04NI	24	19	12	30.0	1/4"	M20x1,5	19	12	0,077
		7360-12SRNI	24	22	12	34.0	3/8"	M20x1,5	22	12	0,100
		7360-12SR08NI	24	27	14	35.5	1/2"	M20x1,5	27	12	0,145
S	400	7360-14SRNI	27	27	14	36.5	1/2"	M22x1,5	27	14	0,164
		7360-16SRNI	30	27	14	37.0	1/2"	M24x1,5	27	16	0,171
		7360-20SRNI	36	32	16	43.0	3/4"	M30x2	32	20	0,272
		7360-25SRNI	46	41	18	48.0	1"	M36x2	40	25	0,506
S	315	7360-30SRNI	50	50	20	51.0	1" 1/4	M42x2	50	30	0,685
		7360-38SRNI	60	55	22	60.0	1" 1/2	M52x2	55	38	0,955

Raccordo diretto Filettatura: Metrica (Form E ISO 9974-2) SWOSDS

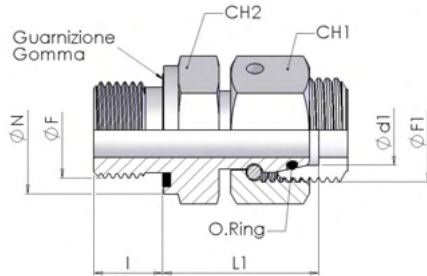

DKO con guarnizione standard: FKM Guarnizione opzionale: NBR, EPDM

Type	W.P. bar	Part number	Dimensions							Weight kg/unit	
			CH1	CH2	I	L1	F	F1	N		Ø tube D1 mm
L	315	7360-06LMNI	14	14	8	24.5	M10x1	M12x1,5	14	6	0,026
		7360-08LMNI	17	17	12	26.5	M12x1,5	M14x1,5	17	8	0,044
		7360-10LMNI	19	19	12	27.5	M14x1,5	M16x1,5	19	10	0,057
		7360-12LMNI	22	22	12	30.5	M16x1,5	M18x1,5	22	12	0,083
		7360-15LMNI	27	24	12	31.5	M18x1,5	M22x1,5	24	15	0,119
		7360-18LMNI	32	27	14	31.5	M22x1,5	M26x1,5	27	18	0,153
L	160	7360-22LMNI	36	32	16	32.5	M26x1,5	M30x2	32	22	0,202
		7360-28LMNI	41	41	18	35.0	M33x2	M36x2	40	28	0,286
		7360-35LMNI	50	50	20	42.5	M42x2	M45x2	50	35	0,500
		7360-42LMNI	60	55	22	46.5	M48x2	M52x2	55	42	0,716
S	630	7360-06SMNI	17	17	12	27.0	M12x1,5	M14x1,5	17	6	0,047
		7360-08SMNI	19	19	12	29.5	M14x1,5	M16x1,5	19	8	0,064
		7360-10SMNI	22	22	12	32.0	M16x1,5	M18x1,5	22	10	0,090
		7360-12SMNI	24	24	12	34.0	M18x1,5	M20x1,5	24	12	0,111
		7360-14SMNI	27	27	14	36.5	M20x1,5	M22x1,5	26	14	0,157
S	400	7360-16SMNI	30	27	14	37.0	M22x1,5	M24x1,5	27	16	0,176
		7360-20SMNI	36	32	16	43.0	M27x2	M30x2	32	20	0,276
		7360-25SMNI	46	41	18	48.0	M33x2	M36x2	40	25	0,505
		7360-30SMNI	50	50	20	51.0	M42x2	M42x2	50	30	0,697
S	315	7360-38SMNI	60	55	22	60.0	M48x2	M52x2	55	38	0,764

Raccordo di riduzione - (serie L) RDSW

DKO con guarnizione standard: FKM Guarnizione opzionale: NBR, EPDM

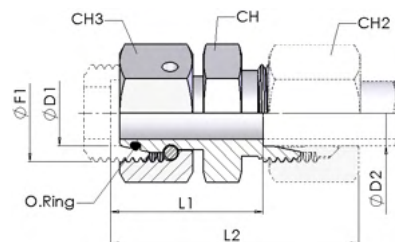

Type	W.P. bar	Part number	Dimensions							Weight kg/unit	
			CH	CH2	CH3	L1	L2	Ø			
								D1	D2	F1	
L	315	7370-08/06L-1NI	12	14	17	23.5	38	8	6	14x1,5	0,029
		7370-10/06L-1NI	14	14	19	25.0	40	10	6	16x1,5	0,038
		7370-10/08L-1NI	14	17	19	25.0	40	10	8	16x1,5	0,038
		7370-12/06L-1NI	17	14	22	25.0	40	12	6	18x1,5	0,050
		7370-12/08L-1NI	17	17	22	25.0	40	12	8	18x1,5	0,051
		7370-12/10L-1NI	17	19	22	26.0	41	12	10	18x1,5	0,052
		7370-15/06L-1NI	22	14	27	28.5	43	15	6	22x1,5	0,087
		7370-15/08L-1NI	22	17	27	28.5	43	15	8	22x1,5	0,088
		7370-15/10L-1NI	22	19	27	29.5	44	15	10	22x1,5	0,089
		7370-15/12L-1NI	22	22	27	29.5	44	15	12	22x1,5	0,090
		7370-18/06L-1NI	24	14	32	28.0	43	18	6	26x1,5	0,111
		7370-18/08L-1NI	24	17	32	28.0	43	18	8	26x1,5	0,111
		7370-18/10L-1NI	24	19	32	29.0	44	18	10	26x1,5	0,112
		7370-18/12L-1NI	24	22	32	29.0	44	18	12	26x1,5	0,113
		7370-18/15L-1NI	24	27	32	30.0	45	18	15	26x1,5	0,118
L	160	7370-22/06L-1NI	27	14	36	32.0	47	22	6	30x2	0,154
		7370-22/08L-1NI	27	17	36	32.0	47	22	8	30x2	0,155
		7370-22/10L-1NI	27	19	36	33.0	48	22	10	30x2	0,157
		7370-22/12L-1NI	27	22	36	33.0	48	22	12	30x2	0,161
		7370-22/15L-1NI	27	27	36	34.0	49	22	15	30x2	0,162
		7370-22/18L-1NI	27	32	36	33.5	50	22	18	30x2	0,166
		7370-28/08L-1NI	36	17	41	34.0	49	28	8	36x2	0,201
		7370-28/10L-1NI	36	19	46	35.0	50	28	10	36x2	0,25
		7370-28/12L-1NI	36	22	41	35.0	50	28	12	36x2	0,201
7370-28/15L-1NI	36	27	41	36.0	51	28	15	36x2	0,206		

Raccordo di riduzione - (serie L) RDSW

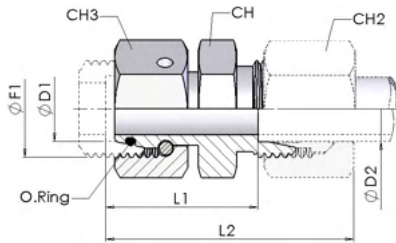

DKO con guarnizione standard: FKM Guarnizione opzionale: NBR, EPDM

Type	W.P. bar	Part number	Dimensions							Weight kg/unit	
			CH	CH2	CH3	L1	L2	Ø			
			CH	CH2	CH3	L1	L2	D1	D2	F1	
L	160	7370-28/18L-1NI	36	32	41	36.5	52	28	18	36x2	0,210
		7370-28/22L-1NI	36	36	41	37.5	54	28	22	36x2	0,210
		7370-35/08L-1NI	41	17	50	37.0	52	35	8	45x2	0,306
		7370-35/10L-1NI	41	19	50	38.0	53	35	10	45x2	0,323
		7370-35/12L-1NI	41	22	50	38.0	53	35	12	45x2	0,313
		7370-35/15L-1NI	41	27	50	39.0	54	35	15	45x2	0,316
		7370-35/18L-1NI	41	32	50	38.5	55	35	18	45x2	0,319
		7370-35/22L-1NI	41	36	50	40.5	57	35	22	45x2	0,321
		7370-35/28L-1NI	41	41	50	40.5	57	35	28	45x2	0,323
		7370-42/06L-1NI	50	14	60	40.5	55	42	6	52x2	0,525
		7370-42/08L-1NI	50	17	60	41.0	48	42	8	52x2	0,52
		7370-42/10L-1NI	50	19	60	42.0	56	42	10	52x2	0,528
		7370-42/12L-1NI	50	22	60	41.5	56	42	12	52x2	0,518
		7370-42/15L-1NI	50	27	60	42.5	58	42	15	52x2	0,534
		7370-42/18L-1NI	50	32	60	42.0	58	42	18	52x2	0,527
		7370-42/22L-1NI	50	36	60	44.0	60	42	22	52x2	0,515
		7370-42/28L-1NI	50	41	60	44.0	61	42	28	52x2	0,515
		7370-42/35L-1NI	50	50	60	43.0	65	42	35	52x2	0,531

Raccordo di riduzione - (serie S) RDSW

DKO con guarnizione standard: FKM Guarnizione opzionale: NBR, EPDM

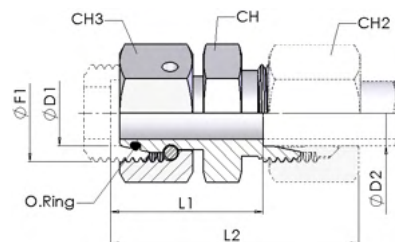

Type	W.P. bar	Part number	Dimensions							Weight kg/unit	
			CH	CH2	CH3	L1	L2	Ø			
								D1	D2	F1	
S	630	7370-08/06S-1NI	14	17	19	27.0	42	8	6	16x1,5	0,043
		7370-10/06S-1NI	17	17	22	27.5	42	10	6	18x1,5	0,055
		7370-10/08S-1NI	17	19	22	27.5	42	10	8	18x1,5	0,057
		7370-12/06S-1NI	19	17	24	29.0	44	12	6	20x1,5	0,070
		7370-12/08S-1NI	19	19	24	29.0	44	12	8	20x1,5	0,071
		7370-12/10S-1NI	19	22	24	29.5	46	12	10	20x1,5	0,073
		7370-14/06S-1NI	22	17	27	31.5	46	14	6	22x1,5	0,094
		7370-14/08S-1NI	22	19	27	31.5	46	14	8	22x1,5	0,095
		7370-14/12S-1NI	22	24	27	31.0	47	14	12	22x1,5	0,104
S	400	7370-16/06S-1NI	22	17	30	32.0	47	16	6	24x1,5	0,114
		7370-16/08S-1NI	22	19	30	32.0	47	16	8	24x1,5	0,116
		7370-16/10S-1NI	22	22	30	31.5	48	16	10	24x1,5	0,117
		7370-16/12S-1NI	22	24	30	31.5	48	16	12	24x1,5	0,120
		7370-16/14S-1NI	24	27	30	33.0	51	16	14	24x1,5	0,128
		7370-20/06S-1NI	27	17	36	36.0	51	20	6	30x2	0,170
		7370-20/08S-1NI	27	19	36	36.0	51	20	8	30x2	0,172
		7370-20/10S-1NI	27	22	36	35.5	52	20	10	30x2	0,170
		7370-20/12S-1NI	27	24	36	35.5	52	20	12	30x2	0,173
		7370-20/16S-1NI	27	30	36	36.5	55	20	16	30x2	0,179
		7370-25/06S-1NI	36	17	46	38.5	53	25	6	36x2	0,309
		7370-25/08S-1NI	36	19	46	38.5	53	25	8	36x2	0,309
		7370-25/10S-1NI	36	22	46	38.0	54	25	10	36x2	0,312
		7370-25/12S-1NI	36	24	46	38.0	54	25	12	36x2	0,313
		7370-25/16S-1NI	36	30	46	39.0	57	25	16	36x2	0,317
		7370-25/20S-1NI	36	36	46	39.0	61	25	20	36x2	0,328

7370

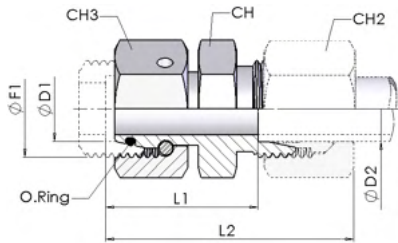

Raccordo di riduzione - (serie S) RDSW

DKO con guarnizione standard: FKM Guarnizione opzionale: NBR, EPDM

Type	W.P. bar	Part number	Dimensions							Weight kg/unit	
			CH	CH2	CH3	L1	L2	Ø			
			CH	CH2	CH3	L1	L2	D1	D2	F1	
S	400	7370-30/08S-1NI	41	22	50	43.5	60	30	8	42x2	0,4
		7370-30/10S-1NI	41	22	50	43.5	60	30	10	42x2	0,404
		7370-30/12S-1NI	41	24	50	43.5	60	30	12	42x2	0,405
		7370-30/16S-1NI	41	30	50	44.5	63	30	16	42x2	0,406
		7370-30/20S-1NI	41	36	50	44.5	66	30	20	42x2	0,422
		7370-30/25S-1NI	41	46	50	45.0	69	30	25	42x2	0,448
S	315	7370-38/06S-1NI	50	17	60	47.5	62	38	6	52x2	0,576
		7370-38/08S-1NI	50	19	60	47.5	62	38	8	52x2	0,578
		7370-38/10S-1NI	50	22	60	47.0	63	38	10	52x2	0,584
		7370-38/12S-1NI	50	24	60	47.0	63	38	12	52x2	0,592
		7370-38/16S-1NI	50	30	60	48.0	66	38	16	52x2	0,592
		7370-38/20S-1NI	50	36	60	48.0	70	38	20	52x2	0,597
		7370-38/25S-1NI	50	46	60	48.5	73	38	25	52x2	0,623
		7370-38/30S-1NI	50	50	60	49.0	76	38	30	52x2	0,636

Raccordo intermedio diritto SW20S

DKO con guarnizioni standard: FKM Guarnizioni opzionali: NBR, EPDM

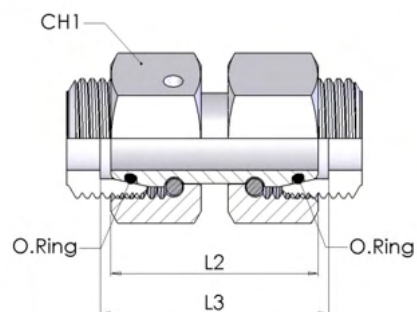

Type	W.P. bar	Part number	Dimensions				Weight kg/unit
			CH1	L2	L3	Ø tube mm	
L	315	7380-06LNI	14	34	35	6	0,029
		7380-08LNI	17	34	35	8	0,044
		7380-10LNI	19	36	37	10	0,059
		7380-12LNI	22	36	37	12	0,077
		7380-15LNI	27	39	40	15	0,143
		7380-18LNI	32	40.5	41.5	18	0,180
L	160	7380-22LNI	36	45	46	22	0,250
		7380-28LNI	41	47	48	28	0,312
		7380-35LNI	50	53	56	35	0,480
		7380-42LNI	60	53	57	42	0,745
S	630	7380-06SNI	17	37	38	6	0,045
		7380-08SNI	19	37	38	8	0,060
		7380-10SNI	22	41	43	10	0,085
		7380-12SNI	24	42	44	12	0,104
		7380-14SNI	27	45	48	14	0,156
S	400	7380-16SNI	30	46	49	16	0,186
		7380-20SNI	36	55	59	20	0,295
		7380-25SNI	46	58	65	25	0,560
		7380-30SNI	50	62	71	30	0,685
S	315	7380-38SNI	60	67	82	38	0,995

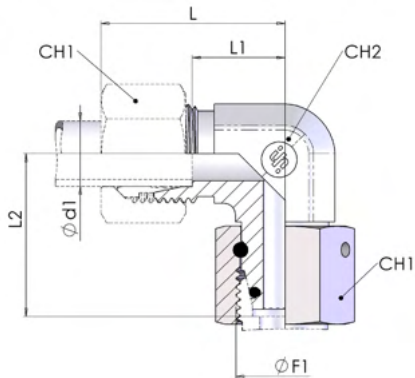

Raccordo Girevole a 90° (ISO 8434-1) SWOE

DKO con guarnizione standard: FKM Guarnizione opzionale: NBR, EPDM

Type	W.P. bar	Part number	Dimensions							Weight kg/unit
			CH1	CH2	L	L1	L2	Ø		
			CH1	CH2	L	L1	L2	F1	tube D1 mm	
L	315	7330-06L-1NI	14	12	27	12.0	26	M12x1,5	6	0,041
		7330-08L-1NI	17	12	29	14.0	27.5	M14x1,5	8	0,062
		7330-10L-1NI	19	14	30	15.0	29	M16x1,5	10	0,053
		7330-12L-1NI	22	17	32	17.0	29.5	M18x1,5	12	0,101
		7330-15L-1NI	27	19	36	21.0	32.5	M22x1,5	15	0,129
		7330-18L-1NI	32	24	40	23.5	35.5	M26x1,5	18	0,186
L	160	7330-22L-1NI	36	27	44	27.5	38.5	M30x2	22	0,253
		7330-28L-1NI	41	36	47	30.5	41.5	M36x2	28	0,342
		7330-35L-1NI	50	41	56	34.5	51	M45x2	35	0,574
		7330-42L-1NI	60	50	63	40.0	56	M52x2	42	1,030
S	630	7330-06S-1NI	17	12	31	16.0	27	M14x1,5	6	0,062
		7330-08S-1NI	19	14	32	17.0	27.5	M16x1,5	8	0,085
		7330-10S-1NI	22	17	34	17.5	30	M18x1,5	10	0,122
		7330-12S-1NI	24	17	38	21.5	31	M20x1,5	12	0,108
		7330-14S-1NI	27	19	40	22.0	35	M22x1,5	14	0,149
S	400	7330-16S-1NI	30	24	43	24.5	36.5	M24x1,5	16	0,201
		7330-20S-1NI	36	27	48	26.5	44.5	M30x2	20	0,305
		7330-25S-1NI	46	36	54	30.0	50	M36x2	25	0,554
		7330-30S-1NI	50	41	62	35.5	55	M42x2	30	0,779
S	315	7330-38S-1NI	60	50	72	41.0	63	M52x2	38	1,186

Raccordo Girevole a 45° (ISO 8434-1) SWOE45

DKO con guarnizione standard: FKM Guarnizione
opzionale: NBR, EPDM

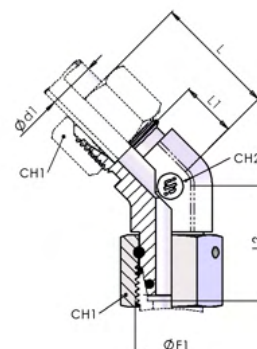

Type	W.P. bar	Part number	Dimensions						Ø tube D1 mm	Weight kg/unit
			CH1	CH2	L	L1	L2	F1		
L	315	7335-06L-1NI	14	12	24	9.0	24	M12x1,5	6	0,069
		7335-08L-1NI	17	12	27	12.0	26	M14x1,5	8	0,075
		7335-10L-1NI	19	14	27	12.0	27	M16x1,5	10	0,078
		7335-12L-1NI	22	19	29	14.0	28	M18x1,5	12	0,086
		7335-15L-1NI	27	22	31	16.0	31	M22x1,5	15	0,126
		7335-18L-1NI	32	27	33.5	17.0	34	M26x1,5	18	0,178
L	160	7335-22L-1NI	36	27	35	18.5	37	M30x2	22	0,236
		7335-28L-1NI	41	36	39	22.5	37	M36x2	28	0,336
		7335-35L-1NI	50	41	44	22.5	41.5	M45x2	35	0,546
		7335-42L-1NI	60	50	49	27	53	M52x2	42	0,841
S	630	7335-06S-1NI	17	12	25	16.0	25	M14x1,5	6	0,073
		7335-08S-1NI	19	14	27	16.0	26	M16x1,5	8	0,082
		7335-10S-1NI	22	19	29	16.5	28	M18x1,5	10	0,095
		7335-12S-1NI	24	19	33	16.5	29	M20x1,5	12	0,112
		7335-14S-1NI	27	22	34	16.0	30	M22x1,5	14	0,136
S	400	7335-16S-1NI	30	27	35	16.5	34	M24x1,5	16	0,188
		7335-20S-1NI	36	27	39	17.5	41	M30x2	20	0,286
		7335-25S-1NI	46	36	43	19.0	39.5	M36x2	25	0,523
		7335-30S-1NI	50	41	50	23.5	42.5	M42x2	30	0,697
		7335-38S-1NI	60	50	55	27	58	M52x2	38	1,067

Raccordo Girevole Laterale a T per tubo 24° (ISO 8434-1)

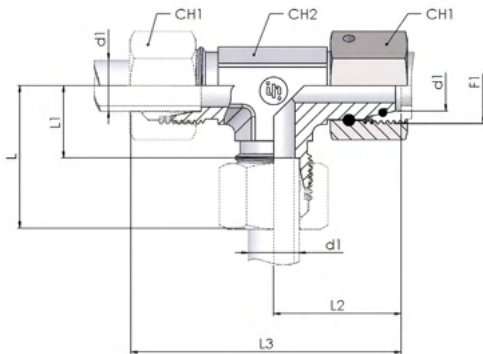

DKO con guarnizione standard: FKM Guarnizione opzionale: NBR, EPDM

Type	W.P. bar	Part number	Dimensions							Ø		Weight kg/unit
			CH1	CH2	L	L1	L2	L3	F1	tube D1 mm		
L	315	7350-06L-1NI	14	12	27	12.0	26	53	M12x1,5	6	0,048	
		7350-08L-1NI	17	12	29	14.0	27.5	56	M14x1,5	8	0,060	
		7350-10L-1NI	19	14	30	15.0	29	59	M16x1,5	10	0,096	
		7350-12L-1NI	22	17	32	17.0	29.5	61	M18x1,5	12	0,110	
		7350-15L-1NI	27	19	36	21.0	32.5	69	M22x1,5	15	0,154	
		7350-18L-1NI	32	24	40	23.5	35.5	75	M26x1,5	18	0,213	
L	160	7350-22L-1NI	36	27	44	27.5	38.5	82	M30x2	22	0,281	
		7350-28L-1NI	41	36	47	30.5	41.5	89	M36x2	28	0,392	
		7350-35L-1NI	50	41	56	34.5	51	107	M45x2	35	0,677	
		7350-42L-1NI	60	50	63	40.0	56	119	M52x2	42	1,124	
S	630	7350-06S-1NI	17	12	31	16.0	27	58	M14x1,5	6	0,078	
		7350-08S-1NI	19	14	32	17.0	27.5	59	M16x1,5	8	0,092	
		7350-10S-1NI	22	17	34	17.5	30	64	M18x1,5	10	0,130	
		7350-12S-1NI	24	17	38	21.5	31	69	M20x1,5	12	0,135	
		7350-14S-1NI	27	19	40	22.0	35	75	M22x1,5	14	0,180	
S	400	7350-16S-1NI	30	24	43	24.5	36.5	79	M24x1,5	16	0,226	
		7350-20S-1NI	36	27	48	26.5	44.5	93	M30x2	20	0,353	
		7350-25S-1NI	46	36	54	30.0	50	104	M36x2	25	0,628	
		7350-30S-1NI	50	41	62	35.5	55	117	M42x2	30	0,917	
S	315	7350-38S-1NI	60	50	72	41.0	63	135	M52x2	38	1,490	

Raccordo Girevole Centrale a T (ISO 8434-1) SWOBT

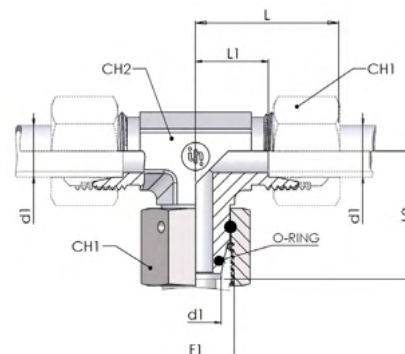

DKO con guarnizione standard: FKM Guarnizione opzionale: NBR, EPDM

Type	W.P. bar	Part number	Dimensions						Weight kg/unit	
			CH1	CH2	L1	L2	F1	L		Ø tube D1 mm
L	315	7340-06L-1NI	14	12	12.0	26	12x1,5	27	6	0,049
		7340-08L-1NI	17	12	14.0	27.5	14x1,5	29	8	0,059
		7340-10L-1NI	19	14	15.0	29	16x1,5	30	10	0,092
		7340-12L-1NI	22	17	17.0	29.5	18x1,5	32	12	0,110
		7340-15L-1NI	27	19	21.0	32.5	22x1,5	36	15	0,154
		7340-18L-1NI	32	24	23.5	35.5	26x1,5	40	18	0,215
L	160	7340-22L-1NI	36	27	27.5	38.5	30x2	44	22	0,277
		7340-28L-1NI	41	36	30.5	41.5	36x2	47	28	0,397
		7340-35L-1NI	50	41	34.5	51	45x2	56	35	0,680
		7340-42L-1NI	60	50	40.0	56	52x2	63	42	1,138
S	630	7340-06S-1NI	17	12	16.0	27	14x1,5	31	6	0,067
		7340-08S-1NI	19	14	17.0	27.5	16x1,5	32	8	0,095
		7340-10S-1NI	22	17	17.5	30	18x1,5	34	10	0,130
		7340-12S-1NI	24	17	21.5	31	20x1,5	38	12	0,135
		7340-14S-1NI	27	19	22.0	35	22x1,5	40	14	0,181
S	400	7340-16S-1NI	30	24	24.5	36.5	24x1,5	43	16	0,246
		7340-20S-1NI	36	27	26.5	44.5	30x2	48	20	0,356
		7340-25S-1NI	46	36	30.0	50	36x2	54	25	0,637
		7340-30S-1NI	50	41	35.5	55	42x2	62	30	0,916
S	315	7340-38S-1NI	60	50	41.0	63	52x2	72	38	1,478

Terminale a 90° Orientabile Metrico con o-ring ed anello

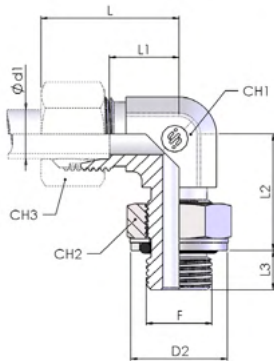

Type	W.P. bar	Part number	Dimensions										Weight kg/unit
			Thread								Ø		
			F	CH1	CH2	CH3	D2	L1	L2	L3	L	tube d1 mm	
L	315	7600-06LM-1NI	M10x1	12	14	14	14.8	12.0	23	6	27	6	0,040
		7600-08LM-1NI	M12x1,5	14	17	17	17.8	14.0	25.5	7.5	29	8	0,061
		7600-10LM-1NI	M14x1,5	14	19	19	19.8	15.0	26	8	30	10	0,065
L	250	7600-12LM-1NI	M16x1,5	17	22	22	21.8	17.0	30	8	32	12	0,096
		7600-15LM-1NI	M18x1,5	19	24	27	23.8	21.0	31.5	9.5	36	15	0,125
		7600-18LM-1NI	M22x1,5	24	27	32	27.8	23.5	33.5	9.5	40	18	0,160
L	160	7600-22LM-1NI	M27x2	27	32	36	32.8	27.5	40	12	44	22	0,279
		7600-28LM-1NI	M33x2	36	41	41	39.8	30.5	44	12	47	28	0,359
		7600-35LM-1NI	M42x2	41	50	50	49.8	34.5	48	12	56	35	0,659
		7600-42LM-1NI	M48x2	50	55	60	55.8	40.0	55	12	63	42	1,064
S	315	7600-06SM-1NI	M12x1,5	14	17	17	17.8	16.0	25.5	7.5	31	6	0,069
		7600-08SM-1NI	M14x1,5	14	19	19	19.8	17.0	26	8	32	8	0,075
		7600-10SM-1NI	M16x1,5	17	22	22	21.8	17.5	30	8	34	10	0,122
		7600-12SM-1NI	M18x1,5	19	24	24	23.8	21.5	31.5	9.5	38	12	0,155
S	250	7600-16SM-1NI	M22x1,5	24	27	30	27.8	24.5	33.5	9.5	43	16	0,246
		7600-20SM-1NI	M27x2	27	32	36	32.8	26.5	40	12	48	20	0,343
S	160	7600-25SM-1NI	M33x2	36	41	46	39.8	30.0	44	12	54	25	0,505
		7600-30SM-1NI	M42x2	41	50	50	49.8	35.5	48	12	62	30	0,769
		7600-38SM-1NI	M48x2	50	55	60	55.8	41.0	55	12	72	38	1,331

Terminale a 90° Orientabile BSPP con o-ring ed anello (ISO 1179)

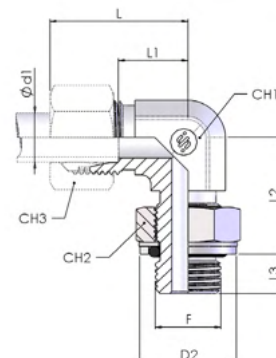

Type	W.P. bar	Part number	Dimensions									Weight kg/unit	
			Thread	F	CH1	CH2	CH3	D2	L1	L2	L3		L
L	200	7600-06LR-1NI	G 1/8	12	14	14	14.8	12.0	21	6	27	6	0,035
		7600-08LR-1NI	G 1/4	14	19	17	19.8	14.0	25	8	29	8	0,045
		7600-10LR-1NI	G 1/4	14	19	19	19.8	15.0	25	8	30	10	0,050
		7600-12LR-1NI	G 3/8	17	22	22	22.8	17.0	29	8	32	12	0,076
		7600-15LR-1NI	G 1/2	19	30	27	27.8	21.0	32.5	10.5	36	15	0,115
		7600-18LR-1NI	G 1/2	24	30	32	27.8	23.5	32.5	10.5	40	18	0,185
L	160	7600-22LR-1NI	G 3/4	27	36	36	32.8	27.5	39	11	44	22	0,336
		7600-28LR-1NI	G 1	36	41	41	40.8	30.5	43	12	47	28	0,437
		7600-35LR-1NI	G 1 1/4	41	50	50	50.8	34.5	46	12	56	35	0,705
		7600-42LR-1NI	G 1 1/2	50	55	60	55.8	40.0	51	12	63	42	1,154
S	200	7600-06SR-1NI	G 1/4	14	19	17	19.8	16.0	21	6	31	6	0,045
		7600-08SR-1NI	G 1/4	14	19	19	19.8	17.0	25	8	32	8	0,055
		7600-10SR-1NI	G 3/8	17	22	22	22.8	17.5	25	8	34	10	0,085
		7600-12SR-1NI	G 3/8	17	22	24	22.8	21.5	29	8	38	12	0,095
		7600-16SR-1NI	G 1/2	24	30	30	27.8	24.5	32.5	10.5	43	16	0,193
		7600-20SR-1NI	G 3/4	27	36	36	32.8	26.5	39	11	48	20	0,362
S	160	7600-25SR-1NI	G 1	36	41	46	40.8	30.0	43	12	54	25	0,465
		7600-30SR-1NI	G 1 1/4	41	50	50	50.8	35.5	46	12	62	30	0,750
		7600-38SR-1NI	G 1 1/2	50	55	60	55.8	41.0	51	12	72	38	1,295

Terminale a 90° Orientabile UNF con o-ring (ISO 11926)

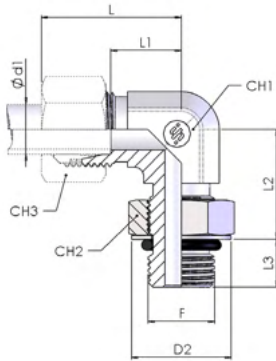

Type	W.P. bar	Part number	Dimensions										Weight kg/unit
			Thread								Ø		
			F	CH1	CH2	CH3	D2	L1	L2	L3	L	tube d1 mm	
L	315	7600-06LU-1NI	7/16-20	12	14	14	16.5	12.0	20	7	27	6	0,032
		7600-08LU-1NI	7/16-20	12	14	17	16.5	14.0	23	7	29	8	0,037
L	250	7600-10LU-1NI	9/16-18	14	17	19	20.2	15.0	25	8	30	10	0,055
		7600-12LU06-1NI	9/16-18	17	17	22	20.2	17.0	25	8	32	12	0,075
		7600-12LU-1NI	3/4-16	17	22	22	25.7	17.0	28	9	32	12	0,092
		7600-15LU08-1NI	3/4-16	19	22	27	25.7	21.0	28	9	36	15	0,115
L	200	7600-15LU-1NI	7/8-14	24	27	27	29.3	21.0	33	10	36	15	0,154
		7600-18LU10-1NI	7/8-14	24	27	32	29.3	23.5	33	10	40	18	0,201
L	160	7600-18LU-1NI	1.1/16-12	27	36	32	36.7	23.5	38	12	40	18	0,223
		7600-22LU-1NI	1.1/16-12	27	36	36	36.7	27.5	38	12	44	22	0,250
L	125	7600-28LU-1NI	1.5/16-12	36	41	41	44	30.5	43	12	47	28	0,446
		7600-35LU-1NI	1.5/8-12	41	50	50	55	34.5	46	12	56	35	0,901
L	125	7600-42LU-1NI	1.7/8-12	50	55	60	62.3	40.0	51	12	63	42	1.043
		7600-06SU-1NI	7/16-20	12	14	17	16.5	16.0	20	7	31	6	0,036
S	400	7600-08SU-1NI	9/16-18	14	17	19	20.2	17.0	25	8	32	8	0,052
		7600-10SU-1NI	9/16-18	17	17	22	20.2	17.5	25	8	34	10	0,073
		7600-12SU-1NI	3/4-16	17	22	24	25.7	21.5	29	9	38	12	0,089
		7600-16SU-1NI	7/8-14	24	27	30	29.3	24.5	33	10	43	16	0,175
		7600-20SU-1NI	1.1/16-12	27	36	36	36.7	26.5	38	12	48	20	0,377
S	315	7600-25SU-1NI	1.5/16-12	36	41	46	44	30.0	43	12	54	25	0,668
S	250	7600-30SU-1NI	1.5/8-12	41	50	50	55	35.5	46	12	62	30	0,901
S	200	7600-38SU-1NI	1.7/8-12	50	55	60	62.3	41.0	51	12	72	38	1,515

Terminale a 90° Orientabile Metrico con o-ring (ISO 6149)

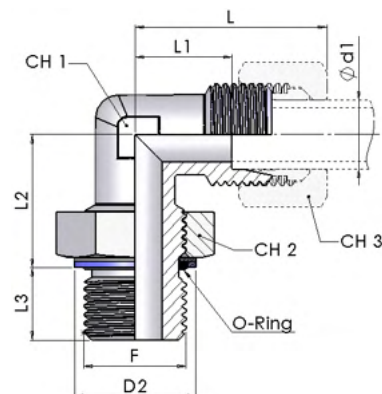

Type	W.P. bar	Part number	Dimensions								
			Thread								Ø
			F	CH1	CH2	CH3	D2	L1	L2	L3	L
315		7605-06LM-1	M10x1	12	14	14	14.5	12.0	21.5	8.5	27
		7605-08LM-1	M12x1,5	14	17	17	17.5	14.0	23.5	11	29
		7605-10LM-1	M14x1,5	14	19	19	19.5	15.0	26.5	11	30
250		7605-12LM-1	M16x1,5	17	22	22	22.5	17.0	27.5	11.5	32
		7605-15LM-1	M18x1,5	19	24	27	24.5	21.0	29	12.5	36
		7605-18LM-1	M22x1,5	24	27	32	27.5	23.5	35	13	40
160		7605-22LM-1	M27x2	27	32	36	32.5	27.5	38.5	16	44
		7605-28LM-1	M33x2	36	41	41	41.5	30.5	41.5	16	47
		7605-35LM-1	M42x2	41	50	50	50.5	34.5	50.5	16	56
		7605-42LM-1	M48x2	50	55	60	55.5	40.0	51.5	17.5	63
400		7605-06SM-1	M12x1,5	12	17	17	17.5	16.0	23.5	11	31
		7605-08SM-1	M14x1,5	14	19	19	19.5	17.0	26.5	11	32
		7605-10SM-1	M16x1,5	17	22	22	22.5	17.5	27.5	12.5	34
		7605-12SM-1	M18x1,5	17	24	24	24.5	21.5	30	14	38
		7605-16SM-1	M22x1,5	24	27	30	27.5	24.5	37	15	43
		7605-20SM-1	M27x2	27	32	36	32.5	26.5	41.5	18.5	48
315		7605-25SM-1	M33x2	36	41	46	41.5	30.0	45.5	18.5	54
250		7605-30SM-1	M42x2	41	50	50	50.5	35.5	53.5	19	62
200		7605-38SM-1	M48x2	50	55	60	55.5	41.0	56.5	21.5	72

Terminale a 45° Orientabile BSPP con o-ring ed anello (ISO 1179)

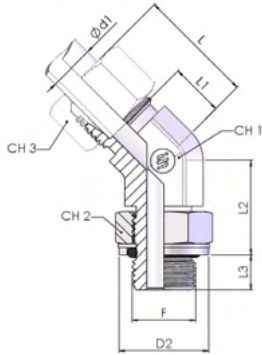

Type	W.P. bar	Part number	Dimensions									Weight kg/unit	
			Thread								Ø		
			F	CH1	CH2	CH3	D2	L	L1	L2	L3	tube d1 mm	
L	315	7630-06LR-1NI	G 1/8	12	14	14	14.8	24	9.0	21	6	6	0,061
		7630-08LR-1NI	G 1/4	14	19	17	19.8	27	12.0	25	8	8	0,065
		7630-10LR-1NI	G 1/4	14	19	19	19.8	27	12.0	25	8	10	0,067
		7630-12LR-1NI	G 3/8	19	22	22	22.8	29	14.0	29	8	12	0,083
		7630-15LR-1NI	G 1/2	22	30	27	27.8	31	16.0	32.5	10.5	15	0,098
		7630-18LR-1NI	G 1/2	27	30	32	27.8	33.5	17.0	32.5	10.5	18	0,185
L	160	7630-22LR-1NI	G 3/4	27	36	36	32.8	35	18.5	39	11	22	0,198
		7630-28LR-1NI	G 1	36	41	41	40.8	39	22.5	43	12	28	0,323
		7630-35LR-1NI	G 1 1/4	41	50	50	50.8	44	22.5	46	12	35	0,537
S	400	7630-06SR-1NI	G 1/8	14	12	14	14.8	25	9.0	21	6	6	0,065
		7630-08SR-1NI	G 1/4	14	19	19	19.8	27	12.0	25	8	8	0,070
		7630-10SR-1NI	G 3/8	19	22	22	22.8	29	12.5	25	8	10	0,091
		7630-12SR-1NI	G 3/8	19	22	24	22.8	33	16.5	29	8	12	0,104
		7630-16SR-1NI	G 1/2	27	30	30	27.8	35	16.5	32.5	10.5	16	0,277
		7630-20SR-1NI	G 3/4	27	36	36	32.8	39	17.5	39	11	20	0,285
S	315	7630-25SR-1NI	G 1	36	41	46	40.8	43	19.0	43	12	25	0,452
S	250	7630-30SR-1NI	G 1 1/4	41	50	50	50.8	50	23.5	46	12	30	0,720

Terminale a 45° Orientabile Metrico con o-ring (ISO 6149)

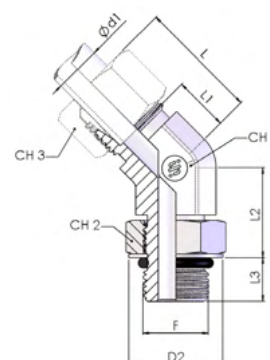

Type	W.P. bar	Part number	Dimensions										Weight kg/unit
			Thread									Ø	
			F	CH1	CH2	CH3	D2	L	L1	L2	L3	tube d1 mm	
L	315	7635-06LM-1NI	M 10x1	12	14	14	14.5	24	9.0	23	6	6	0,061
		7635-08LM-1NI	M 12x1,5	14	17	17	17.5	27	12.0	25.5	7.5	8	0,065
		7635-10LM-1NI	M 14x1,5	14	19	19	19.5	27	12.0	26	8	10	0,069
L	250	7635-12LM-1NI	M 16x1,5	19	22	22	22.5	29	14.0	30	8	12	0,081
		7635-15LM-1NI	M 18x1,5	22	24	27	24.5	31	16.0	31.5	9.5	15	0,085
		7635-18LM-1NI	M 22x1,5	27	27	32	27.5	33.5	17.0	32.5	9.5	18	0,198
L	160	7635-22LM-1NI	M 27x2	27	32	36	32.5	35	18.5	40	12	22	0,201
		7635-28LM-1NI	M 33x2	36	41	41	41.5	39	22.5	44	12	28	0,323
		7635-35LM-1NI	M 42x2	41	50	50	50.5	44	22.5	48	12	35	0,637
S	400	7635-06SM-1NI	M 12x1,5	14	17	17	17.5	25	9.0	25.5	7.5	6	0,065
		7635-08SM-1NI	M 14x1,5	14	19	19	19.5	27	12.0	26	8	8	0,071
		7635-10SM-1NI	M 16x1,5	19	22	22	22.5	29	12.5	30	8	10	0,091
		7635-12SM-1NI	M 18x1,5	22	24	24	24.5	33	16.5	31.5	9.5	12	0,110
		7635-16SM-1NI	M 22x1,5	27	27	30	27.5	35	16.5	32.5	9.5	16	0,183
		7635-20SM-1NI	M 27x2	27	32	36	32.5	39	17.5	40	12	20	0,277
S	315	7635-25SM-1NI	M 33x2	36	41	46	41.5	43	19.0	44	12	25	0,452
S	250	7635-30SM-1NI	M 42x2	41	50	50	50.5	50	23.5	48	12	30	0,720

Terminale a T Orientabile Laterale BSPP con o-ring ed anello (ISO 1179)

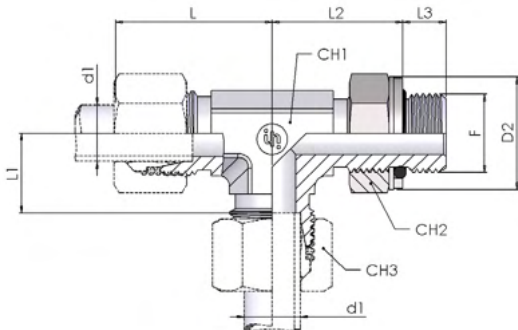

Type	W.P. bar	Part number	Dimensions										Weight kg/unit
			Thread	CH1	CH2	CH3	D2	L	L1	L2	L3	Ø tube d1 mm	
L	200	7610-06LR-1NI	G 1/8	12	14	14	14.8	27	12.0	21	6	6	0,039
		7610-08LR-1NI	G 1/4	14	19	17	19.8	29	14.0	25	8	8	0,048
		7610-10LR-1NI	G 1/4	14	19	19	19.8	30	15.0	25	8	10	0,055
		7610-12LR-1NI	G 3/8	17	22	22	22.8	32	17.0	29	8	12	0,072
		7610-15LR-1NI	G 1/2	19	30	27	27.8	36	21.0	32.5	10.5	15	0,122
		7610-18LR-1NI	G 1/2	24	30	32	27.8	40	23.5	32.5	10.5	18	0,190
L	160	7610-22LR-1NI	G 3/4	27	36	36	32.8	44	27.5	39	11	22	0,282
		7610-28LR-1NI	G 1	36	41	41	40.8	47	30.5	43	12	28	0,468
		7610-35LR-1NI	G 1 1/4	41	50	50	50.8	56	34.5	46	12	35	0,901
		7610-42LR-1NI	G 1 1/2	50	55	60	55.8	63	40.0	51	12	42	1,028
S	200	7610-06SR-1NI	G 1/4	14	19	17	19.8	31	16.0	25	8	6	0,056
		7610-08SR-1NI	G 1/4	14	19	19	19.8	32	17.0	25	8	8	0,060
		7610-10SR-1NI	G 3/8	17	22	22	22.8	34	17.5	29	8	10	0,089
		7610-12SR-1NI	G 3/8	17	22	24	22.8	38	21.5	29	8	12	0,092
		7610-16SR-1NI	G 1/2	24	30	30	27.8	43	24.5	32.5	10.5	16	0,296
		7610-20SR-1NI	G 3/4	27	36	36	32.8	48	26.5	39	11	20	0,377
		7610-25SR-1NI	G 1	36	41	46	40.8	54	30.0	43	12	25	0,667
S	160	7610-30SR-1NI	G 1 1/4	41	50	50	50.8	62	35.5	46	12	30	1,164
		7610-38SR-1NI	G 1 1/2	50	55	60	55.8	72	41.0	51	12	38	1,514

Terminale a T Orientabile Laterale UNF con o-ring (ISO 11926)

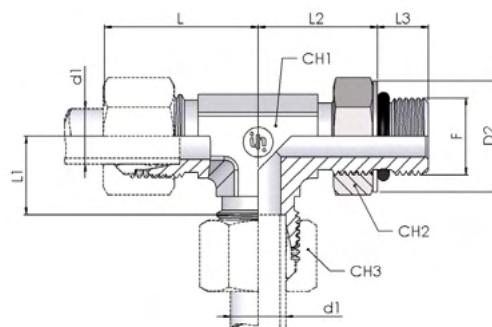

Type	W.P. bar	Part number	Dimensions										Weight kg/unit
			Thread	CH1	CH2	CH3	D2	L	L1	L2	L3	\emptyset tube d1 mm	
L	315	7610-06LU-1NI	7/16-20	12	14	14	16.5	27	12.0	20	7	6	0,036
		7610-08LU-1NI	7/16-20	12	14	17	16.5	29	14.0	20	7	8	0,039
L	250	7610-10LU-1NI	9/16-18	14	17	19	20.2	30	15.0	25	8	10	0,051
		7610-12LU06-1NI	9/16-18	17	17	22	20.2	32	17.0	25	8	12	0,070
		7610-12LU-1NI	3/4-16	17	22	22	25.7	32	17.0	28	9	12	0,071
		7610-15LU08-1NI	3/4-16	19	22	27	25.7	36	21.0	28	9	15	0,106
L	200	7610-15LU-1NI	7/8-14	24	27	27	29.3	36	21.0	33	10	15	0,201
		7610-18LU10-1NI	7/8-14	27	27	32	29.3	40	23.5	33	10	18	0,214
		7610-18LU-1NI	1.1/16-12	27	32	32	36.7	40	23.5	38	12	18	0,269
L	160	7610-22LU-1NI	1.1/16-12	27	32	36	36.7	44	27.5	38	12	22	0,282
		7610-28LU-1NI	1.5/16-12	36	41	41	44	47	30.5	43	12	28	0,468
L	125	7610-35LU-1NI	1.5/8-12	41	50	50	55	56	34.5	46	12	35	0,901
		7610-42LU-1NI	1.7/8-12	50	55	60	62.3	63	40.0	51	12	42	1,028
S	400	7610-06SU-1NI	7/16-20	12	14	17	16.5	31	16.0	20	7	6	0,040
		7610-08SU-1NI	9/16-18	14	17	19	20.2	32	17.0	25	8	8	0,060
		7610-10SU-1NI	9/16-18	17	17	22	20.2	34	17.5	25	8	10	0,075
		7610-12SU-1NI	3/4-16	17	22	24	25.7	38	21.5	28	9	12	0,081
		7610-16SU-1NI	7/8-14	24	27	30	29.3	43	24.5	33	10	16	0,221
		7610-20SU-1NI	1.1/16-12	27	32	36	36.7	48	26.5	38	12	20	0,267
S	315	7610-25SU-1NI	1.5/16-12	36	41	46	44	54	30.0	43	12	25	0,667
S	250	7610-30SU-1NI	1.5/8-12	41	50	50	55	62	35.5	46	12	30	1,164
S	200	7610-38SU-1NI	1.7/8-12	50	55	60	62.3	72	41.0	51	12	38	1,514

Terminale a T Orientabile Laterale Metrico con o-ring (ISO 6149)

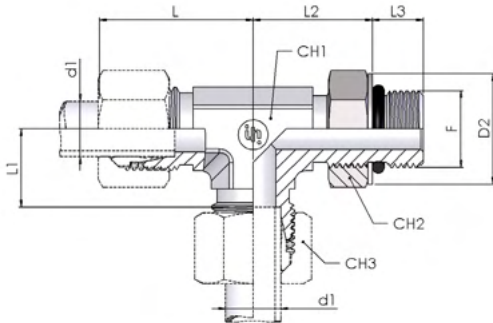

Type	W.P. bar	Part number	Dimensions									Weight kg/unit	
			Thread								Ø		
			F	CH1	CH2	CH3	D2	L	L1	L2	L3	Ø tube d1 mm	
L	315	7615-06LM-1NI	M 10x1	12	14	14	14.5	27	12.0	23	6	6	0,039
		7615-08LM-1NI	M 12x1,5	14	17	17	17.5	29	14.0	25.5	7.5	8	0,052
		7615-10LM-1NI	M 14x1,5	14	19	19	19.5	30	15.0	26	8	10	0,055
L	250	7615-12LM-1NI	M 16x1,5	17	22	22	22.5	32	17.0	30	8	12	0,069
		7615-15LM-1NI	M 18x1,5	19	24	27	24.5	36	21.0	31.5	9.5	15	0,106
		7615-18LM-1NI	M 22x1,5	24	27	32	27.5	40	23.5	32.5	9.5	18	0,198
L	160	7615-22LM-1NI	M 27x2	27	32	36	32.5	44	27.5	40	12	22	0,0282
		7615-28LM-1NI	M 33x2	36	41	41	41.5	47	30.5	44	12	28	0,468
		7615-35LM-1NI	M 42x2	41	50	50	50.5	56	34.5	48	12	35	0,901
		7615-42LM-1NI	M 48x2	50	55	60	55.5	63	40.0	54	13	42	1,028
S	400	7615-06SM-1NI	M 12x1,5	12	17	17	17.5	31	16.0	25.5	7.5	6	0,041
		7615-08SM-1NI	M 14x1,5	14	19	19	19.5	32	17.0	26	8	8	0,055
		7615-10SM-1NI	M 16x1,5	17	22	22	22.5	34	17.5	30	8	10	0,075
		7615-12SM-1NI	M 18x1,5	17	24	24	24.5	38	21.5	31.5	9.5	12	0,077
		7615-16SM-1NI	M 22x1,5	24	27	30	27.5	43	24.5	32.5	9.5	16	0,201
		7615-20SM-1NI	M 27x2	27	32	36	32.5	48	26.5	40	12	20	0,377
S	315	7615-25SM-1NI	M 33x2	36	41	46	41.5	54	30.0	44	12	25	0,667
S	250	7615-30SM-1NI	M 42x2	41	50	50	50.5	62	35.5	48	12	30	1,116
S	200	7615-38SM-1NI	M 48x2	50	55	60	55.5	72	41.0	54	13	38	1,514

Terminale a T Orientabile Centrale BSPP con o-ring ed anello (ISO 1179)

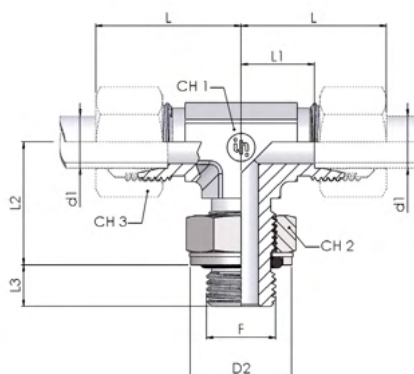

Type	W.P. bar	Part number	Dimensions										Weight kg/unit
			Thread								Ø		
			F	CH1	CH2	CH3	D2	L1	L2	L3	L	tube d1 mm	
L	200	7620-06LR-1NI	G 1/8	12	14	14	14.8	12.0	21	6	27	6	0,038
		7620-08LR-1NI	G 1/4	14	19	17	19.8	14.0	25	8	29	8	0,051
		7620-10LR-1NI	G 1/4	14	19	19	19.8	15.0	25	8	30	10	0,055
		7620-12LR-1NI	G 3/8	17	22	22	22.8	17.0	29	8	32	12	0,073
		7620-15LR-1NI	G 1/2	19	30	27	27.8	21.0	32.5	10.5	36	15	0,108
		7620-18LR-1NI	G 1/2	24	30	32	27.8	23.5	32.5	10.5	40	18	0,221
L	160	7620-22LR-1NI	G 3/4	27	36	36	32.8	27.5	39	11	44	22	0,285
		7620-28LR-1NI	G 1	36	41	41	40.8	30.5	43	12	47	28	0,475
		7620-35LR-1NI	G 1 1/4	41	50	50	50.8	34.5	46	12	56	35	0,855
		7620-42LR-1NI	G 1 1/2	50	55	60	55.8	40.0	51	12	63	42	1,028
S	200	7620-06SR-1NI	G 1/4	14	19	17	19.8	16.0	21	6	31	6	0,045
		7620-08SR-1NI	G 1/4	14	19	19	19.8	17.0	25	8	32	8	0,061
		7620-10SR-1NI	G 3/8	17	22	22	22.8	17.5	29	8	34	10	0,073
		7620-12SR-1NI	G 3/8	17	22	24	22.8	21.5	29	8	38	12	0,077
		7620-16SR-1NI	G 1/2	24	30	30	27.8	24.5	32.5	10.5	43	16	0,222
		7620-20SR-1NI	G 3/4	27	36	36	32.8	26.5	39	11	48	20	0,291
		7620-25SR-1NI	G 1	36	41	46	40.8	30.0	43	12	54	25	0,477
S	160	7620-30SR-1NI	G 1 1/4	41	50	50	50.8	35.5	46	12	62	30	0,899
		7620-38SR-1NI	G 1 1/2	50	55	60	55.8	41.0	51	12	72	38	1,028

Terminale a T Orientabile Centrale UNF con o-ring (ISO 11926)

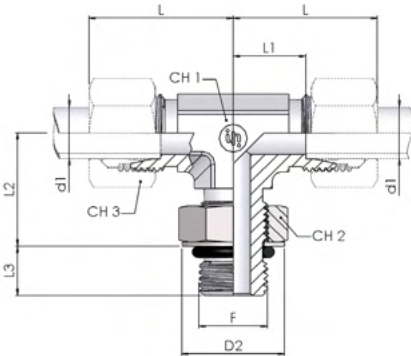

Type	W.P. bar	Part number	Dimensions										Weight kg/unit
			Thread	CH1	CH2	CH3	D2	L	L1	L2	L3	Ø tube d1 mm	
L	315	7620-06LU-1NI	7/16-20	12	14	14	16.5	27	12.0	20	7	6	0,036
		7620-08LU-1NI	7/16-20	12	14	17	16.5	29	14.0	20	7	8	0,039
L	250	7620-10LU-1NI	9/16-18	14	17	19	20.2	30	15.0	25	8	10	0,049
		7620-12LU06-1NI	9/16-18	17	17	22	20.2	32	17.0	25	8	12	0,073
		7620-12LU-1NI	3/4-16	17	22	22	25.7	32	17.0	28	9	12	0,075
		7620-15LU08-1NI	3/4-16	19	22	27	25.7	36	21.0	28	9	15	0,108
L	200	7620-15LU-1NI	7/8-14	24	27	27	29.3	36	21.0	33	10	15	0,201
		7620-18LU10-1NI	7/8-14	24	27	32	29.3	40	23.5	33	10	18	0,210
L	160	7620-18LU-1NI	1.1/16-12	27	32	32	36.7	40	23.5	38	12	18	0,282
		7620-22LU-1NI	1.1/16-12	27	32	36	36.7	44	27.5	38	12	22	0,290
L	125	7620-28LU-1NI	1.5/16-12	36	41	41	44	47	30.5	43	12	28	0,473
		7620-35LU-1NI	1.5/8-12	41	50	50	55	56	34.5	46	12	35	0,901
L	125	7620-42LU-1NI	1.7/8-12	50	55	60	62.3	63	40.0	51	12	42	1,028
		7620-06SU-1NI	7/16-20	12	14	17	16.5	31	16.0	20	7	6	0,039
S	400	7620-08SU-1NI	9/16-18	14	17	19	20.2	32	17.0	25	8	8	0,059
		7620-10SU-1NI	9/16-18	17	17	22	20.2	34	17.5	25	8	10	0,073
		7620-12SU-1NI	3/4-16	17	22	24	25.7	38	21.5	28	9	12	0,077
		7620-16SU-1NI	7/8-14	24	27	30	29.3	43	24.5	33	10	16	0,210
		7620-20SU-1NI	1.1/16-12	27	32	36	36.7	48	26.5	38	12	20	0,380
S	315	7620-25SU-1NI	1.5/16-12	36	41	46	44	54	30.0	43	12	25	0,668
S	250	7620-30SU-1NI	1.5/8-12	41	50	50	55	62	35.5	46	12	30	1,168
S	200	7620-38SU-1NI	1.7/8-12	50	55	60	62.3	72	41.0	51	12	38	1,515

Terminale a T Orientabile Centrale Metrico con o-ring (ISO 6149)

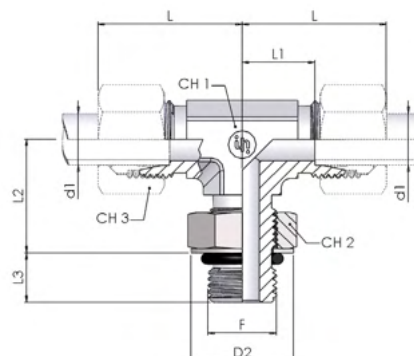

Type	W.P. bar	Part number	Dimensions										Weight kg/unit
			Thread									Ø	
			F	CH1	CH2	CH3	D2	L	L1	L2	L3	Ø tube d1 mm	
L	315	7625-06LM-1NI	M 10x1	12	14	14	14.5	27	12.0	23	6	6	0,041
		7625-08LM-1NI	M 12x1,5	14	17	17	17.5	29	14.0	25.5	7.5	8	0,047
		7625-10LM-1NI	M 14x1,5	14	19	19	19.5	30	15.0	26	8	10	0,055
L	250	7625-12LM-1NI	M 16x1,5	17	22	22	22.5	32	17.0	30	8	12	0,073
		7625-15LM-1NI	M 18x1,5	19	24	27	24.5	36	21.0	31.5	9.5	15	0,108
		7625-18LM-1NI	M 22x1,5	24	27	32	27.5	40	23.5	32.5	9.5	18	0,210
L	160	7625-22LM-1NI	M 27x2	27	32	36	32.5	44	27.5	40	12	22	0,295
		7625-28LM-1NI	M 33x2	36	41	41	41.5	47	30.5	44	12	28	0,475
		7625-35LM-1NI	M 42x2	41	50	50	50.5	56	34.5	48	12	35	0,901
		7625-42LM-1NI	M 48x2	50	55	60	55.5	63	40.0	54	13	42	1,028
S	400	7625-06SM-1NI	M 12x1,5	12	17	17	17.5	31	16.0	25.5	7.5	6	0,041
		7625-08SM-1NI	M 14x1,5	14	19	19	19.5	32	17.0	26	8	8	0,061
		7625-10SM-1NI	M 16x1,5	17	22	22	22.5	34	17.5	30	8	10	0,075
		7625-12SM-1NI	M 18x1,5	17	24	24	24.5	38	21.5	31.5	9.5	12	0,081
		7625-16SM-1NI	M 22x1,5	24	27	30	27.5	43	24.5	32.5	9.5	16	0,221
		7625-20SM-1NI	M 27x2	27	32	36	32.5	48	26.5	40	12	20	0,377
S	315	7625-25SM-1NI	M 33x2	36	41	46	41.5	54	30.0	44	12	25	0,668
S	250	7625-30SM-1NI	M 42x2	41	50	50	50.5	62	35.5	48	12	30	1,168
S	200	7625-38SM-1NI	M 48x2	50	55	60	55.5	72	41.0	54	13	38	1,515

Riduzione Maschio-Femmina Form E (Form E ISO 1179- 2)

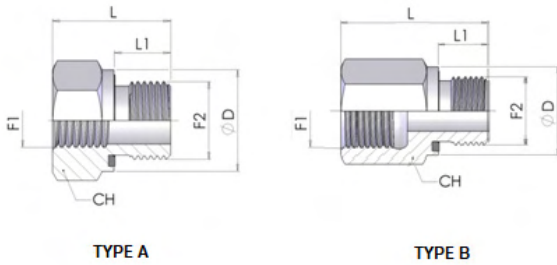

Type	W.P. bar	Part number	Dimensions					Ø	Weight kg/unit
			Thread		CH	L	L1		
			F1	F2					
B	630	7240-0204NI	G 1/4	G 1/8	19	32	8.0	14	0,042
		7240-0206NI	G 3/8	G 1/8	24	32	8.0	14	0,068
		7240-0402NI	G 1/8	G 1/4	19	28	12.0	18	0,046
		7240-0406NI	G 3/8	G 1/4	24	36	12.0	18	0,073
		7240-0408NI	G 1/2	G 1/4	30	40	12.0	18	0,124
B	400	7240-0412NI	G 3/4	G 1/4	36	43	12.0	18	0,185
A	630	7240-0602NI	G 1/8	G 3/8	22	22,5	12.0	22	0,038
B	630	7240-0604NI	G 1/4	G 3/8	22	36	12.0	22	0,072
		7240-0608NI	G 1/2	G 3/8	30	41	12.0	22	0,132
B	400	7240-0612NI	G 3/4	G 3/8	36	44	12.0	22	0,191
A	630	7240-0802NI	G 1/8	G 1/2	27	24	14.0	26	0,065
		7240-0804NI	G 1/4	G 1/2	27	24	14.0	26	0,056
		7240-0806NI	G 3/8	G 1/2	27	36	14.0	26	0,097
B	400	7240-0812NI	G 3/4	G 1/2	36	46	14.0	26	0,194
		7240-0816NI	G 1	G 1/2	41	49	14.0	26	0,237
B	250	7240-0820NI	G 1 1/4	G 1/2	55	53	14.0	26	0,503
A	400	7240-1204NI	G 1/4	G 3/4	32	26	16.0	32	0,101
		7240-1206NI	G 3/8	G 3/4	32	26	16.0	32	0,085
B	400	7240-1208NI	G 1/2	G 3/4	32	41	16.0	32	0,150
		7240-1216NI	G 1	G 3/4	41	51	16.0	32	0,247

Riduzione Maschio-Femmina Form E (Form E ISO 1179- 2)

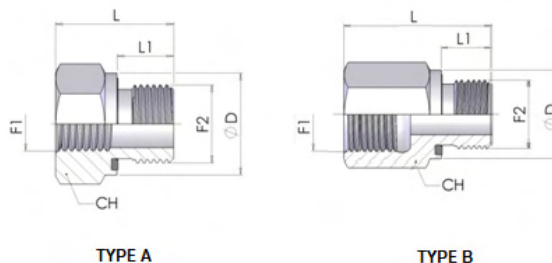

Type	W.P. bar	Part number	Dimensions						Weight kg/unit
			Thread		CH	L	L1	Ø	
			F1	F2					
B	250	7240-1220NI	G 1 1/4	G 3/4	55	55	16.0	32	0,514
		7240-1224NI	G 1 1/2	G 3/4	60	57	16.0	32	0,596
A	400	7240-1604NI	G 1/4	G 1	41	29	18.0	39	0,193
		7240-1606NI	G 3/8	G 1	41	29	18.0	39	0,178
		7240-1608NI	G 1/2	G 1	41	29	18.0	39	0,152
B	400	7240-1612NI	G 3/4	G 1	41	47	18.0	39	0,286
B	250	7240-1620NI	G 1 1/4	G 1	55	57	18.0	39	0,549
		7240-1624NI	G 1 1/2	G 1	60	59	18.0	39	0,626
A	250	7240-2008NI	G 1/2	G 1 1/4	50	32	20.0	49	0,309
		7240-2012NI	G 3/4	G 1 1/4	50	32	20.0	49	0,260
B	250	7240-2016NI	G 1	G 1 1/4	50	52	20.0	49	0,482
		7240-2024NI	G 1 1/2	G 1 1/4	60	60	20.0	49	0,659
A	250	7240-2408NI	G 1/2	G 1 1/2	55	36	22.0	55	0,467
		7240-2412NI	G 3/4	G 1 1/2	55	36	22.0	55	0,416
		7240-2416NI	G 1	G 1 1/2	55	36	22.0	55	0,336
B	250	7240-2420NI	G 1 1/4	G 1 1/2	55	58	22.0	55	0,553

Terminale diritto femmina Filettatura: BSPP S

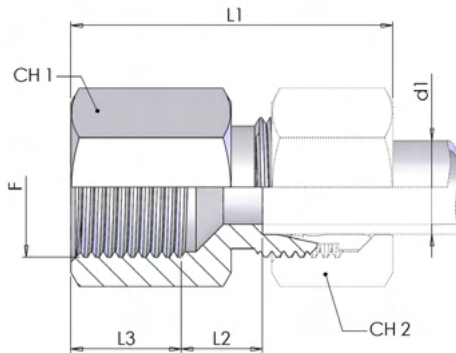

Filettatura: BSPP

Type	W.P. bar	Part number	Dimensions					Ø tube mm	Weight kg/unit	
			Thread	CH1	CH2	L1	L2			L3
L	315	7250-06LR-1NI	G 1/8	14	14	33.5	7	12	6	0,018
		7250-08LR06-1NI	G 3/8	24	17	40.0	10.5	14.5	8	0,062
		7250-08LR08-1NI	G 1/2	27	17	44.0	14.5	14.5	8	0,079
		7250-08LR-1NI	G 1/4	19	17	39.0	7	17	8	0,038
		7250-10LR06-1NI	G 3/8	24	19	41.0	11.5	14.5	10	0,062
		7250-10LR08-1NI	G 1/2	27	19	45.0	15.5	14.5	10	0,081
		7250-10LR-1NI	G 1/4	19	19	40.0	8	17	10	0,039
		7250-12LR08-1NI	G 1/2	27	22	45.0	15.5	14.5	12	0,084
		7250-12LR-1NI	G 3/8	24	22	40.5	9	17	12	0,062
		7250-15LR-1NI	G 1/2	27	27	46.0	11	20	15	0,086
L	160	7250-18LR-1NI	G 1/2	27	32	47.0	10.5	20	18	0,089
		7250-22LR-1NI	G 3/4	36	36	52.0	13.5	22	22	0,173
		7250-28LR-1NI	G 1	41	41	54.0	13	24.5	28	0,209
		7250-35LR-1NI	G 1 1/4	55	50	63.0	15	26.5	35	0,457
S	630	7250-42LR-1NI	G 1 1/2	60	60	66.0	14.5	28.5	42	0,528
		7250-06SR-1NI	G 1/4	19	17	41.0	9	17	6	0,042
		7250-08SR-1NI	G 1/4	19	19	41.0	9	17	8	0,044
		7250-10SR-1NI	G 3/8	24	22	42.5	9.5	17	10	0,069
		7250-12SR-1NI	G 3/8	24	24	42.5	9.5	17	12	0,071
S	400	7250-14SR-1NI	G 1/2	30	27	50.0	12	20	14	0,094
		7250-16SR-1NI	G 1/2	30	30	50.0	11.5	20	16	0,093
		7250-20SR-1NI	G 3/4	36	36	56.0	12.5	22	20	0,189
		7250-25SR-1NI	G 1	41	46	61.0	12.5	24.5	25	0,240
S	315	7250-30SR-1NI	G 1 1/4	55	50	69.0	16	26.5	30	0,503
S	315	7250-38SR-1NI	G 1 1/2	60	60	75.0	15.5	28.5	38	0,615

Terminale diritto femmina Filettatura: Metrica S

Filettatura: Metric

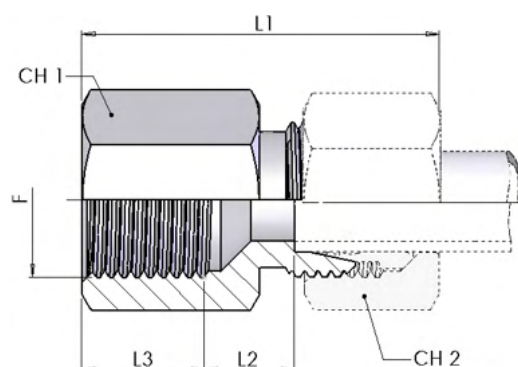

Type	W.P. bar	Part number	Dimensions						Ø tube mm	Weight kg/unit
			Thread							
			F	CH1	CH2	L1	L2	L3		
L	315	7250-06LM-1NI	M 10x1	14	14	33.5	7	12	6	0,018
		7250-08LM-1NI	M 12x1,5	17	17	39.0	7	17	8	0,031
		7250-10LM-1NI	M 14x1,5	19	19	40.0	8	17	10	0,037
		7250-12LM-1NI	M 16x1,5	22	22	40.5	9	17	12	0,051
		7250-15LM-1NI	M 18x1,5	24	27	46.0	14	17	15	0,065
		7250-18LM-1NI	M 22x1,5	30	30	47.0	11.5	19	18	0,109
L	160	7250-22LM-1NI	M 26x1,5	32	36	51.0	13.5	21	22	0,121
S	630	7250-06SM-1NI	M 12x1,5	17	17	41.0	9	17	6	0,048
		7250-08SM-1NI	M 14x1,5	19	19	41.0	9	17	8	0,042
		7250-10SM-1NI	M 16x1,5	22	22	42.5	9.5	17	10	0,058
		7250-12SM-1NI	M 18x1,5	24	24	42.5	9.5	17	12	0,069
		7250-14SM-1NI	M 20x1,5	27	27	50.0	13	19	14	0,096
S	400	7250-16SM-1NI	M 22x1,5	30	30	50.0	12.5	19	16	0,115
		7250-20SM-1NI	M 27x2	36	36	56.0	12.5	22	20	0,186

7030

Terminale Portamanometro (ISO 8434-1) SGC

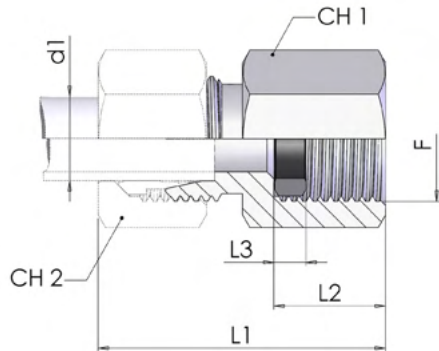

Type	W.P. bar	Part number	Dimensions						Weight kg/unit	
			Thread	CH1	CH2	L1	L2	L3		\varnothing tube mm
L	315	7030-06L-1NI	G 1/4	19	14	37.0	14.5	4.5	6	0,037
		7030-08L-1NI	G 1/4	19	17	37.0	14.5	4.5	8	0,038
		7030-10L-1NI	G 1/4	19	19	38.0	14.5	4.5	10	0,039
		7030-12L-1NI	G 1/4	19	22	38.0	14.5	4.5	12	0,040
S	630	7030-06S-1NI	G 1/2	27	17	46.0	20	5	6	0,086
		7030-08S-1NI	G 1/2	27	19	46.0	20	5	8	0,090
		7030-10S-1NI	G 1/2	27	22	47.0	20	5	10	0,088
		7030-12S-1NI	G 1/2	27	24	47.0	20	5	12	0,090

Terminale Portamanometro girevole (ISO 8434-1) SWOGC

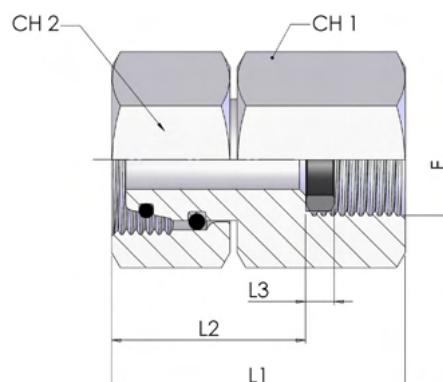

Type	W.P. bar	Part number	Dimensions						Ø tube mm	Weight kg/unit
			Thread	CH1	CH2	L1	L2	L3		
			F	CH1	CH2	L1	L2	L3		
L	315	7035-06LNI	G 1/4	19	14	37.5	23	4.6	6	0,048
		7035-08LNI	G 1/4	19	17	37.5	23	4.6	8	0,055
		7035-10LNI	G 1/4	19	19	36.0	21.5	4.6	10	0,058
		7035-12LNI	G 1/4	19	22	36.0	21.5	4.6	12	0,069
S	630	7035-06SNI	G 1/2	27	17	44.5	24.5	5.2	6	0,103
		7035-08SR04NI	G 1/4	19	19	35.5	21	4.6	8	0,073
		7035-08SNI	G 1/2	27	19	44.5	24.5	5.2	8	0,117
		7035-10SR04NI	G 1/4	19	22	39.0	24.5	4.6	10	0,087
		7035-10SNI	G 1/2	27	22	43.5	23.5	5.2	10	0,113
		7035-12SR04NI	G 1/4	19	24	40.0	24.5	4.6	12	0,102
		7035-12SNI	G 1/2	27	24	45.0	25	5.2	12	0,122

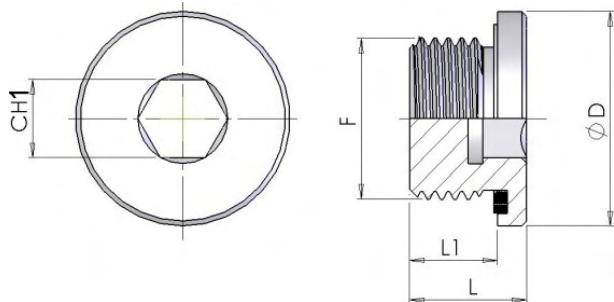

Tappo con esagono incassato
Filettatura: BSPP
(Form E ISO 1179-2)
PLE

Type	W.P. bar	Part number	Dimensions					Weight kg/unit
			CH1	D	F	L	L1	
400		7260-02NI	5	14	G 1/8	12	8.0	0,007
		7260-04NI	6	19	G 1/4	17	12.0	0,018
		7260-06NI	8	22	G 3/8	17	12.0	0,027
		7260-08NI	10	27	G 1/2	19	14.0	0,044
		7260-12NI	12	32	G 3/4	21	16.0	0,075
		7260-16NI	17	40	G 1	22.5	16.0	0,123
315		7260-20NI	22	50	G 1 1/4	22.5	20.0	0,272
		7260-24NI	24	55	G 1 1/2	22.5	22.0	0,375

Tappo con esagono incassato
Filettatura: Metrica
(Form E ISO 9974-2)
PLE

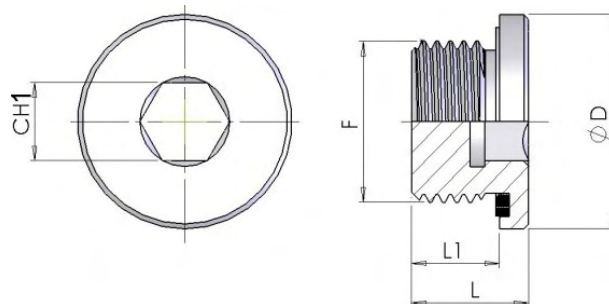

Type	W.P. bar	Part number	Dimensions					Weight kg/unit
			CH1	D	F	L	L1	
400		7260-10X10NI	5	14	M10x1	12	8.0	0,007
		7260-12X15NI	6	17	M12x1,5	17	12.0	0,014
		7260-14X15NI	6	19	M14x1,5	17	12.0	0,019
		7260-16X15NI	8	22	M16x1,5	17	12.0	0,024
		7260-18X15NI	8	24	M18x1,5	17	12.0	0,032
		7260-20X15NI	10	26	M20x1,5	19	14.0	0,040
		7260-22X15NI	10	27	M22x1,5	19	14.0	0,050
		7260-26X15NI	12	32	M26x1,5	21	16.0	0,074
		7260-27X20NI	12	32	M27x2	21	16.0	0,077
		7260-33X20NI	17	40	M33x2	22.5	16.0	0,124
315		7260-42X20NI	22	50	M42x2	22.5	16.0	0,186
		7260-48X20NI	24	55	M48x2	22.5	16.0	0,244

Tappo Maschio (ISO 8434-1) PL

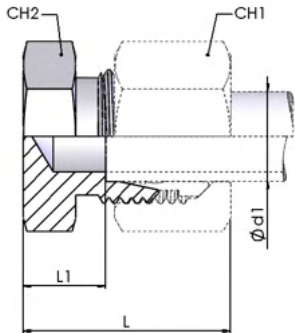

Type	W.P. bar	Part number	Dimensions				Ø tube D1 mm	Weight kg/unit
			CH1	CH2	L	L1		
L	315	7270-06L-1NI	14	12	22	17.5	6	0,008
		7270-08L-1NI	17	14	23	18.5	8	0,012
		7270-10L-1NI	19	17	24	19.5	10	0,016
		7270-12L-1NI	22	19	25	10.5	12	0,022
		7270-15L-1NI	27	24	26	11.5	15	0,038
		7270-18L-1NI	32	27	28	11.5	18	0,054
L	160	7270-22L-1NI	36	32	30	13.5	22	0,077
		7270-28L-1NI	41	41	31	14.5	28	0,133
		7270-35L-1NI	50	46	36	14.5	35	0,201
		7270-42L-1NI	60	55	39	16.5	42	0,340
S	630	7270-06S-1NI	17	14	26	11.5	6	0,016
		7270-08S-1NI	19	17	28	13.5	8	0,026
		7270-10S-1NI	22	19	29	12.5	10	0,031
		7270-12S-1NI	24	22	31	14.5	12	0,045
		7270-14S-1NI	27	24	34	16.5	14	0,059
S	400	7270-16S-1NI	30	27	34	15.5	16	0,068
		7270-20S-1NI	36	32	39	17.5	20	0,120
		7270-25S-1NI	46	41	44	20.5	25	0,213
		7270-30S-1NI	50	46	47	20.5	30	0,281
S	315	7270-38S-1NI	60	55	54	23.5	38	0,498

Tappo con O-ring (ISO 8434-1) PL

Con cono di tenuta e O-Ring adattabile alla forma del foro W DIN 3861/ISO 8434-1

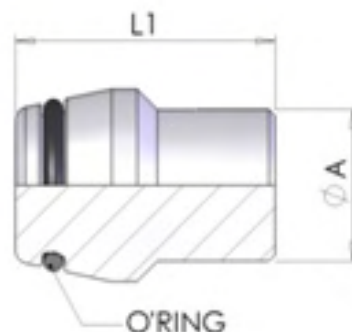

Type	W.P. bar	Part number	Dimensions			Weight kg/unit
			A	L	Ø tube mm	
LS	315	7290-06LSNI	6	17	6	0,006
		7290-08LSNI	8	17	8	0,010
		7290-10LSNI	10	18.5	10	0,016
		7290-12LSNI	12	19.5	12	0,022
L	315	7290-15LNI	15	19.5	15	0,032
		7290-18LNI	18	21.5	18	0,051
L	160	7290-22LNI	22	24	22	0,081
		7290-28LNI	28	24.5	28	0,130
		7290-35LNI	35	28	35	0,240
		7290-42LNI	42	28	42	0,346
S	630	7290-14SNI	14	22.5	14	0,032
S	400	7290-16SNI	16	21.5	16	0,041
		7290-20SNI	20	27	20	0,080
		7290-25SNI	25	27.5	25	0,124
		7290-30SNI	30	29.5	30	0,182
S	315	7290-38SNI	38	31	38	0,315

Terminale diretto a saldare (ISO 8434-1)

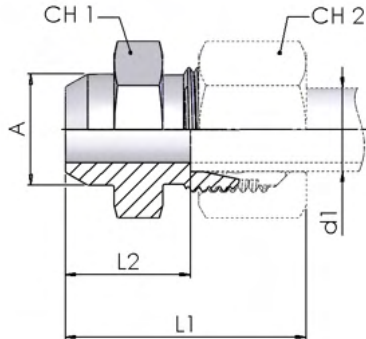

Type	W.P. bar	Part number	Dimensions					Ø tube mm	Weight kg/unit
			A	CH1	CH2	L1	L2		
L	315	7420-06L-1	10	12	14	29.0	14	6	0,010
		7420-08L-1	12	14	17	31.0	16	8	0,015
		7420-10L-1	14	17	19	33.0	18	10	0,021
		7420-12L-1	16	19	22	33.0	18	12	0,026
		7420-15L-1	19	22	27	37.0	22	15	0,043
		7420-18L-1	22	27	32	40.0	23.5	18	0,066
L	160	7420-22L-1	27	32	36	45.0	28.5	22	0,097
		7420-28L-1	32	41	41	47.0	30.5	28	0,159
		7420-35L-1	40	46	50	54.0	32.5	35	0,228
		7420-42L-1	46	55	60	58.0	35	42	0,328
S	630	7420-06S-1	11	14	17	34.0	19	6	0,021
		7420-08S-1	13	17	19	36.0	21	8	0,030
		7420-10S-1	15	19	22	39.0	22.5	10	0,040
		7420-12S-1	17	22	24	41.0	24.5	12	0,055
		7420-14S-1	19	24	27	45.0	27	14	0,070
S	400	7420-16S-1	21	27	30	45.0	26.5	16	0,083
		7420-20S-1	26	32	36	51.0	29.5	20	0,129
		7420-25S-1	31	41	46	56.0	32	25	0,222
S	315	7420-30S-1	36	46	50	62.0	35.5	30	0,295
S	315	7420-38S-1	44	55	60	69.0	38	38	0,455

Terminale Passaparete a saldare (ISO 8434-1) WDBHS

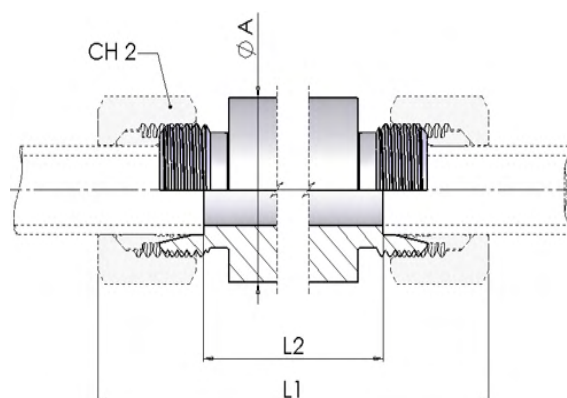

Type	W.P. bar	Part number	Dimensions					Weight kg/unit
			A	CH 2	L1	L2	Ø tube mm	
L	315	7120-06L-1	18	14	85.0	56	6	0,103
		7120-08L-1	20	17	85.0	56	8	0,121
		7120-10L-1	22	19	87.0	58	10	0,143
		7120-12L-1	25	22	87.0	58	12	0,177
		7120-15L-1	28	27	100.0	70	15	0,259
		7120-18L-1	32	32	101.0	69	18	0,334
L	160	7120-22L-1	36	36	105.0	73	22	0,400
		7120-28L-1	40	41	106.0	73	28	0,445
		7120-35L-1	50	50	114.0	71	35	0,723
		7120-42L-1	60	60	115.0	70	42	1,005
S	630	7120-06S-1	20	17	89.0	60	6	0,135
		7120-08S-1	22	19	89.0	60	8	0,162
		7120-10S-1	25	22	91.0	59	10	0,200
		7120-12S-1	28	24	91.0	59	12	0,250
		7120-14S-1	30	27	107.0	72	14	0,337
S	400	7120-16S-1	35	30	107.0	71	16	0,444
		7120-20S-1	38	36	114.0	71	20	0,515
		7120-25S-1	45	46	120.0	72	25	0,723
		7120-30S-1	50	50	126.0	73	30	0,873
S	315	7120-38S-1	60	60	133.0	72	38	1,251

Nipplo a saldare con tenuta ad O-Ring WDNP

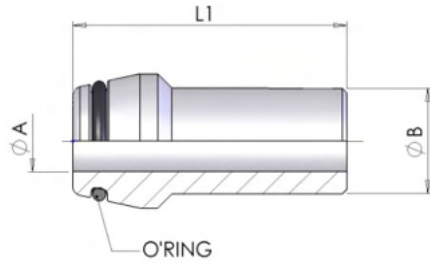

Con cono di tenuta e O-Ring adattabile alla forma del foro W DIN 3861/
ISO 8434-1

W.P. bar	Part number	Dimensions		Weight kg/unit
		L1	Ø tube mm	
400	7280-10X20	31.0	10	0,016
	7280-12X25	31.0	12	0,022
	7280-14X30	34.0	14	0,035
	7280-16X30	37.0	16	0,044
	7280-20X40	43.0	20	0,078
	7280-25X40	48.0	25	0,112
	7280-30X50	51.0	30	0,171
315	7280-38X50	55.0	38	0,245

Indice

7400	pag 6
7410	pag 7
7430.....	pag 8
7440	pag 13
7435	pag 16
7450	pag 18
7460	pag 21
7500	pag 24
7510	pag 25
7520	pag 27
7000	pag 28
7010	pag 29
7020	pag 30
7130	pag 31
M107	pag 32
7360	pag 33
7370	pag 35
7380	pag 39
7330	pag 40
7335	pag 41
7350	pag 42
7340	pag 43
7600	pag 44
7605	pag 47
7630	pag 48
7635	pag 49
7610	pag 50
7615	pag 52
7620	pag 53
7625	pag 55
7240	pag 56
7250	pag 58
7030	pag 60
7035	pag 61
7260	pag 62

Indice

7270	pag 64
7290	pag 65
7420	pag 66
7120	pag 67
7280	pag 68

NPTF/METRIC

in



1750



Male Union

4

1770

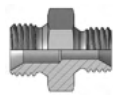

Male-Male Reducing

5

1810



Male Metric-Female
BSP Reducing

6

1820



Male BSP-Female
Metric Reducing

7

M105

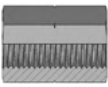

Female Union

8

M608



Swivel plug

9

M605



Male plug

10



1870

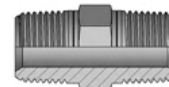

Male Union

11

N105



Female Union

12

4690



90° Elbow Male Union

13

4695



90° Elbow M/F

14

4580



90° Elbow Female
Union

15

4830

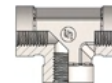

Tee Female Union

16

4920

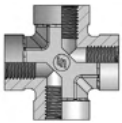

Cross Female Union

17



1500



Weldable Metric

18

1570



Metric Threaded

19

1580



Metric Threaded

20

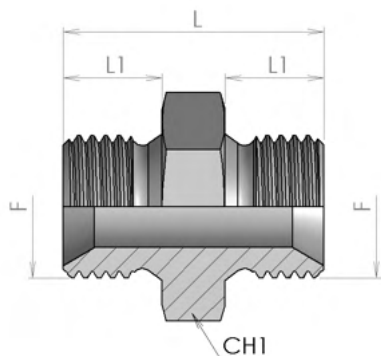

Unione diretto maschio Metrico cono 60°

S

Part number	Dimensions				Weight kg/unit
	F	L	L1	CH1	
1750-10-10	M 10x1	25	8	14	0.011
1750-12-12	M 12x1,5	29	12	17	0.019
1750-14-14	M 14x1,5	29	12	19	0.028
1750-16-16	M 16x1,5	33	12	22	0.037
1750-18-18	M 18x1,5	36	12	24	0.050
1750-20-20	M 20x1,5	38	14	27	0.067
1750-22-22	M 22x1,5	38	14	27	0.069
1750-24-24	M 24x1,5	41	14	30	0.092
1750-26-26	M 26x1,5	43	16	32	0.109
1750-30-30	M30x1,5	43	17	36	0.136

Riduzione diretto maschio Metrico cono 60°

S

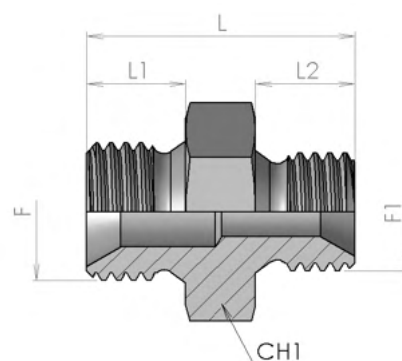

Part number	Dimensions						Weight kg/unit
	F	F1	L	L1	L2	CH1	
1770-14-12	M 14x1,5	M 12x1,5	29	12	12	19	0.026
1770-16-14	M 16x1,5	M 14x1,5	31	12	12	22	0.033
1770-18-14	M 18x1,5	M 14x1,5	33	12	12	24	0.044
1770-18-16	M 18x1,5	M 16x1,5	35	12	12	24	0.047
1770-22-16	M 22x1,5	M 16x1,5	36	14	12	27	0.056
1770-22-18	M 22x1,5	M 18x1,5	37	14	12	27	0.060
1770-26-22	M 26x1,5	M 22x1,5	41	16	14	32	0.091

M105

Unione diretto femmina metrica

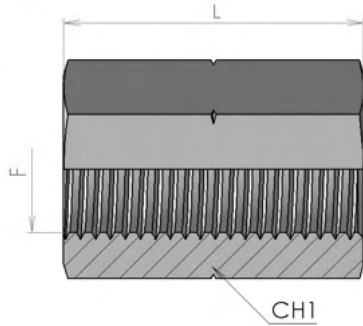

S

Part number	Dimensions			Weight kg/unit
	F	L	CH1	
M105-10-10	M 10x1	25	14	0.014
M105-12-12	M 12x1,5	25	17	0.031
M105-14-14	M 14x1,5	35	19	0.026
M105-16-16	M 16x1,5	35	22	0.059
M105-18-18	M 18x1,5	45	24	0.101
M105-22-22	M 22x1,5	45	27	0.930

Colonna Maschio Metrico-Femmina BSP

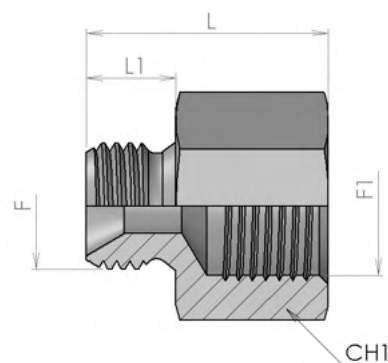
S

Part number	Dimensions							Weight kg/unit
	Ø		F	F1	L	L1	CH1	
	tube mm	tube inch						
1810-04-14	8	5/16"	M 14x1,5	G 1/4	28	10	19	0.042
1810-06-16	10	3/8"	M 16x1,5	G 3/8	33	11	22	0.055
1810-06-18	10	3/8"	M 18x1,5	G 3/8	34	11	24	0.058
1810-08-22	12	1/2"	M 22x1,5	G 1/2	37	12	27	0.071

Colonna Maschio BSP-Femmina Metrica

S

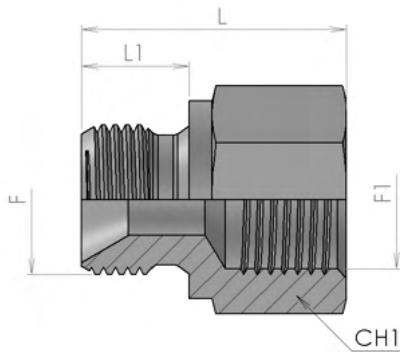

Part number	Dimensions							Weight kg/unit
	Ø		F	F1	L	L1	CH1	
	tube mm	tube inch						
1820-04-14	8	5/16"	G 1/4	M 14x1,5	27	11	17	0.042
1820-06-16	10	3/8"	G 3/8	M 16x1,5	33	12	22	0.055
1820-06-18	10	3/8"	G 3/8	M 18x1,5	33	12	24	0.058
1820-08-18	12	1/2"	G 1/2	M 18x1,5	35	14	27	0.065
1820-08-22	12	1/2"	G 1/2	M 22x1,5	36	14	27	0.071

Tappo metrico girevole

PL

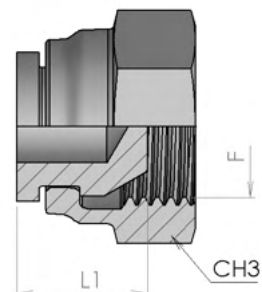

Part number	Dimensions			Weight kg/unit
	F	L1	CH3	
M608-12	M 12x1,5	10.5	17	0.005
M608-14	M 14x1,5	12	19	0.008
M608-16	M 16x1,5	15	22	0.014
M608-18	M 18x1,5	15	24	0.018
M608-20	M 20x1,5	17	27	0.024
M608-22	M 22x1,5	17	27	0.028
M608-26	M 26x1,5	19	32	0.044

M605

Tappo metrico

PL

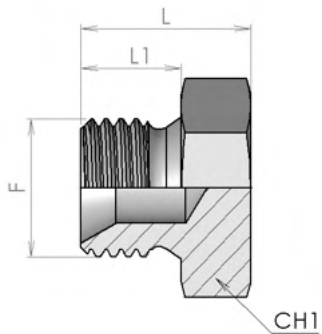

Part number	Dimensions				Weight kg/unit
	F	L	L1	CH1	
M605-10	M 10x1	13	8	14	0.009
M605-12	M 12x1,5	17	10	17	0.016
M605-14	M 14x1,5	17	10	19	0.023
M605-16	M 16x1,5	18	11	22	0.030
M605-18	M 18x1,5	19	11	24	0.041
M605-20	M 20x1,5	22	14	27	0.055
M605-22	M 22x1,5	20	12	27	0.057
M605-24	M 24x1,5	22	14	30	0.075
M605-26	M 26x1,5	24	16	32	0.089

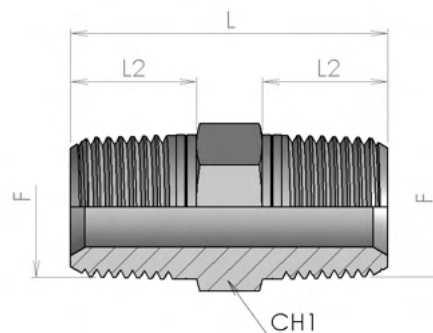
Unione diretto maschio NPTF
S

Part number	Dimensions						Weight kg/unit
	Ø		F	L	L2	CH1	
	tube mm	tube inch					
1870-02-02	6	1/4"	1/8 NPTF	27	10	12	0.020
1870-04-04	8	5/16"	1/4 NPTF	35.5	14.5	15	0.033
1870-06-06	10	3/8"	3/8 NPTF	37.5	14.5	19	0.047
1870-08-08	12	1/2"	1/2 NPTF	48	19	22	0.085
1870-12-12	20	3/4"	3/4 NPTF	53	19.5	27	0.144
1870-16-16	25	1"	1 NPTF	63	24	36	0.270
1870-20-20	32	1.1/4"	1 1/4 NPTF	68	24.5	46	0.401
1870-24-24	38	1.1/2"	1 1/2 NPTF	71	25.5	50	0.477
1870-32-32	50	2"	2 NPTF	74.5	26	65	0.898

Adattatore diretto femmina NPTF

S

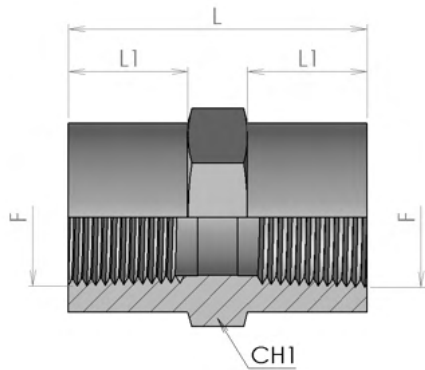

Part number	Dimensions				Weight kg/unit
	F	L	L1	CH1	
N105-02-02	1/8 NPTF	19	6.5	16	0.019
N105-04-04	1/4 NPTF	29	11	19	0.045
N105-06-06	3/8 NPTF	29	11	22	0.062
N105-08-08	1/2 NPTF	38	14	30	0.112
N105-12-12	3/4 NPTF	39	14	36	0.156
N105-16-16	1 NPTF	48	17.5	41	0.289
N105-20-20	1 1/4 NPTF	49	17.5	50	0.340
N105-24-24	1 1/2 NPTF	49	17.5	60	0.531

Unione a 90° NPTF

E

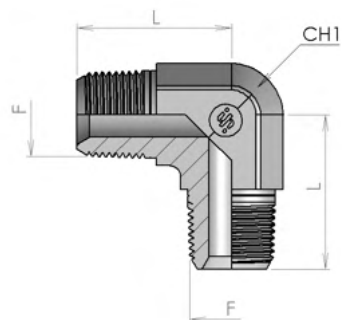

Part number	Dimensions					Weight kg/unit
	Ø		F	L	CH1	
	tube mm	tube inch				
4690-02	6	1/4"	1/8 NPTF	19.5	12	0.015
4690-04	8	5/16"	1/4 NPTF	27.5	14	0.042
4690-06	10	3/8"	3/8 NPTF	31	19	0.093
4690-08	12	1/2"	1/2 NPTF	36	22	0.142
4690-12	20	3/4"	3/4 NPTF	40.5	27	0.231

4695

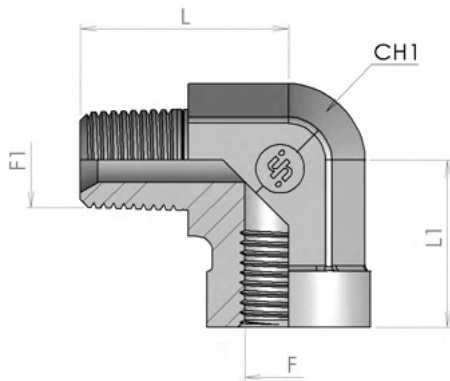

Gomito 90° M NPTF/ Femmina NPTF

SDE

Part number	Dimensions							Weight kg/unit
	Ø		F	F1	L	L1	CH1	
	tube mm	tube inch						
4695-02	6	1/4"	1/8 NPTF	1/8 NPTF	23.5	17	14	0.048
4695-04	8	5/16"	1/4 NPTF	1/4 NPTF	29	22.5	19	0.065
4695-06	10	3/8"	3/8 NPTF	3/8 NPTF	33.5	26	22	0.008
4695-08	12	1/2"	1/2 NPTF	1/2 NPTF	38	31	27	0.147
4695-12	20	3/4"	3/4 NPTF	3/4 NPTF	45	34.5	33	0.210
4695-16	25	1"	1 NPTF	1 NPTF	55	41	41	0.402
4695-20	32	1.1/4"	1 1/4 NPTF	1 1/4 NPTF	63	43	50	0.655

Unione 90° femmina NPTF

E

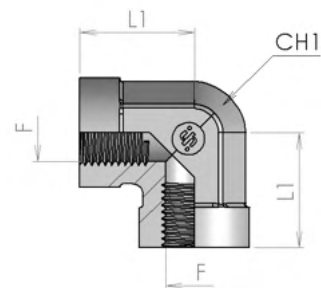

Part number	Dimensions					Weight kg/unit
	Ø		F	L1	CH1	
	tube mm	tube inch				
4580-02	6	1/4"	1/8 NPTF	17	14	0.060
4580-04	8	5/16"	1/4 NPTF	22.5	19	0.081
4580-06	10	3/8"	3/8 NPTF	26	22	0.010
4580-08	12	1/2"	1/2 NPTF	31	27	0.184
4580-12	20	3/4"	3/4 NPTF	34.5	33	0.263
4580-16	25	1"	1 NPTF	41	41	0.502
4580-20	32	1.1/4"	1 1/4 NPTF	43	50	0.663

Unione a T femmina NPTF

T

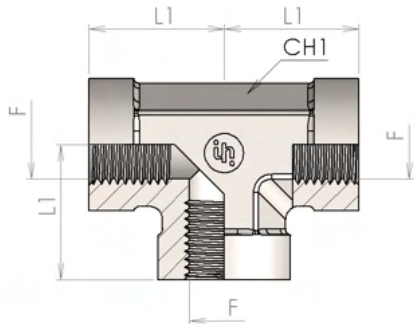

Part number	Dimensions					Weight kg/unit
	Ø		F	L1	CH1	
	tube mm	tube inch				
4830-02	6	1/4"	1/8 NPTF	17	14	0.080
4830-04	8	5/16"	1/4 NPTF	22.5	19	0.108
4830-06	10	3/8"	3/8 NPTF	26	22	0.013
4830-08	12	1/2"	1/2 NPTF	31	27	0.245
4830-12	20	3/4"	3/4 NPTF	34.5	33	0.351
4830-16	25	1"	1 NPTF	41	41	0.669
4830-20	32	1.1/4"	1 1/4 NPTF	43	50	0.884

Unione a croce femmina NPTF

K

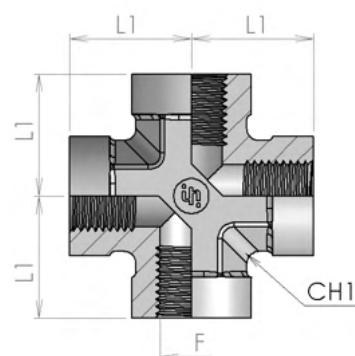

Part number	Dimensions					Weight kg/unit
	Ø		F	L1	CH1	
	tube mm	tube inch				
4920-02	6	1/4"	1/8 NPTF	17	14	0.100
4920-04	8	5/16"	1/4 NPTF	22.5	19	0.135
4920-06	10	3/8"	3/8 NPTF	26	22	0.017
4920-08	12	1/2"	1/2 NPTF	31	27	0.307

Occhio metrico a saldare

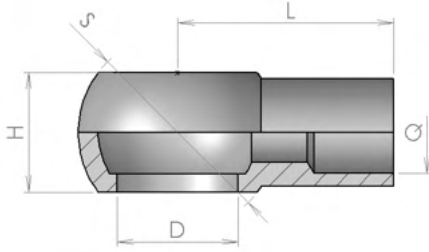

Part number	Dimensions					Weight kg/unit
	D	L	H	S	Q	
1500-08-05	8	15	8	14	5	0.006
1500-10-06	10.5	19	10.5	17	6	0.009
1500-12-08	12	22	12	20	8	0.015
1500-14-10	14	24	14	24	10	0.021
1500-16-10	16	28	18	28	10	0.038
1500-16-12	16	28	17	28	12	0.036
1500-18-12	18	30	20	32	12	0.055
1500-18-14	18	29	18	32	14	0.056
1500-22-16	22	34	22	35	16	0.057
1500-22-18	22	32	22	35	18	0.054
1500-26-22	26	40	29	45	22	0.111

Occhio filettato metrico

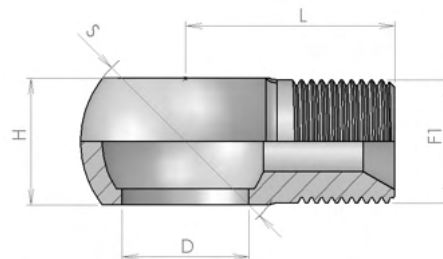

Part number	Dimensions				Weight kg/unit
	F1	D	L	S	
1570-14-14	M 14x1,5	14	25	24	0.027
1570-18-18	M 18x1,5	18	30	32	0.067
1570-22-22	M 22x1,5	22	32	35	0.081

Occhio filettato metrico cono 24°

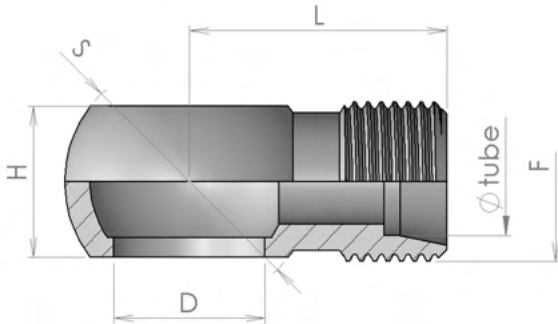

Part number	Dimensions						Weight kg/unit
	Ø						
	tube mm	F	D	L	H	S	
1580-06-18	12	M 18x1,5	3/8"	29	17	28	0.044
1580-08-18	12	M 18x1,5	1/2"	33.5	22	36	0.086
1580-08-22	15	M 22x1,5	1/2"	32.5	22	36	0.091



Indice

1750	pag 4
1770	pag 5
1810	pag 6
1820	pag 7
M105	pag 8
M608	pag 9
M605.....	pag 10
1870	pag 11
N105	pag 12
4690	pag 13
4695	pag 14
4580	pag 15
4830	pag 16
4920	pag 17
1500	pag 18
1570	pag 19
1580	pag 20



INTERPUMP

FLUID SOLUTIONS 

Powered by I.M.M. Hydraulics



I.M.M. Hydraulics Spa
interpumpfluidsolutions.com

Via Italia, 49-51
66041 - Atessa (Ch) - Italy
T. +39 (0) 0872 889225
F. +39 (0) 0872 889226



CAT-IFS-A